



Owner's Manual for the Vehicle.
With a quick reference guide
for your convenience.



BMW recommends Castrol



525i

530i

540i

sedan

sport wagon

Congratulations, and thank you for choosing a BMW.

Thorough familiarity with your vehicle will provide you with enhanced control and security when you drive it. We therefore have this request:

Please take the time to read this Owner's Manual and familiarize yourself with the information that we have compiled for you before starting off in your new car. It contains important data and instructions intended to assist you in gaining maximum use and satisfaction from the unique range of technical features on your BMW. The manual also contains information on care and maintenance designed to enhance operating safety and contribute to maintaining the value of your vehicle throughout an extended service life.

This Owner's Manual should be considered a permanent part of this vehicle. It should stay with the vehicle when sold to provide the next owner with important operating, safety and maintenance information.

This manual is supplemented by a Service and Warranty Information Booklet (US models) or a Warranty and Service Guide Booklet (Canadian models). We recommend that you read this publication thoroughly.

Your BMW is covered by the following warranties:

- New Vehicle Limited Warranty
- Limited Warranty Rust Perforation
- Federal Emissions System Defect Warranty
- Federal Emissions Performance Warranty
- California Emission Control System Limited Warranty

Detailed information about these warranties is listed in the Service and Warranty Information Booklet (US models) or in the Warranty and Service Guide Booklet (Canadian models).

We wish you an enjoyable driving experience.

BMW AG

Notes on the Owner's Manual

We have made every effort to ensure that you are able to find what you need in this Owner's Manual as quickly as possible. The fastest way to find certain topics is by using the detailed index at the end. If you desire an initial overview of your vehicle, this can be found in the first chapter. The detailed table of contents that directly follows the summary of contents is intended to stimulate your curiosity regarding your BMW and to encourage you to read the manual.

Should you wish to sell your BMW at some time in the future, please remember to hand over the Owner's Manual to the new owner; it is part of the vehicle.

If you have any additional questions, an authorized BMW center will be glad to advise you.

© 2000 BMW AG
Munich, Germany
Reprinting, including excerpts, only with the written consent of BMW AG, Munich.
Order No. 01 41 0 155 420
US English I/2001
Printed in Germany
Printed on environmentally friendly paper (bleached without chlorine, suitable for recycling).

Symbols used

 Indicates instructions or precautions that must be followed precisely in order to avoid the possibility of personal injury and serious damage to the vehicle. ◀

 Contains information that will assist you in gaining the optimum benefit from your vehicle and enable you to care more effectively for your vehicle. ◀

 Refers to measures that can be taken to help protect the environment. ◀

◀ Marks the end of a specific item of information.

* Indicates special equipment, country-specific equipment and optional extras.

 Indicates index entries that refer to owner service and maintenance procedures

 Identifies systems or components, which your BMW center can either activate or adapt to suit an individual driver's requirements ("Car Memory", "Key Memory"). Refer to page 60. ◀

The individual vehicle

On buying your BMW, you have decided in favor of a model with individualized equipment and features. This Owner's Manual describes all models and equipment that BMW offers within the same group.

We hope you will understand that equipment and features are included which you might not have chosen for your vehicle. Any differences can easily be identified, since all optional accessories and special equipment are marked with an asterisk *.

If your BMW features equipment which is not described in this Owner's Manual (car radio, for instance), Supplementary Owner's Manuals are enclosed. We ask you to read these manuals as well.

Status at time of printing

BMW pursues a policy of continuous, ongoing development that is conceived to ensure that our vehicles continue to embody the highest quality and safety standards combined with advanced, state-of-the-art technology. For this reason, it is possible that the features described in this Owner's Manual could differ from those on your vehicle. Nor can errors and omissions be entirely ruled out. You are therefore asked to appreciate that no legal claims can be entertained on the basis of the data, illustrations or descriptions in this manual.

For your own safety



Use unleaded gasoline only. Fuels containing up to 10% ethanol or other oxygenates with up to 2.8% oxygen by weight (that is, 15% MTBE or 3% methanol plus an equivalent amount of co-solvent) will not void the applicable warranties with respect to defects in materials or workmanship. Field experience has indicated significant differences in fuel quality (volatility, composition, additives, etc.) among gasolines offered for sale in the United States and Canada. The use of poor-quality fuels may result in driveability, starting and stalling problems, especially under certain environmental conditions, such as high ambient temperature and high altitude. Should you encounter driveability problems that you suspect could be related to the fuel you are using, we recommend that you respond by switching to a recognized high-quality brand. Failure to comply with these recommendations may result in unscheduled maintenance. Follow the relevant safety rules when you are handling gasoline. ◀



Important safety information!

For your own safety, use genuine parts and accessories approved by BMW. When you purchase accessories tested and approved by BMW and Original BMW Parts, you simultaneously acquire the assurance that they have been thoroughly tested by BMW to ensure optimum performance when installed on your vehicle. BMW warrants these parts to be free from defects in material and workmanship. BMW will not accept any liability for damage resulting from installation of parts and accessories not approved by BMW. BMW cannot test every product from other manufacturers to verify if it can be used on a BMW safely and without risk to either the vehicle, its operation, or its occupants. Original BMW Parts, BMW Accessories and other products approved by BMW, together with professional advice on using these items, are available from all BMW centers.

Installation and operation of non-BMW approved accessories such as alarms, radios, amplifiers, radar detectors, wheels, suspension components, brake dust shields, telephones (including operation of any portable cellular phone from within the vehicle without using an externally-mounted antenna) or transmitter equipment (for instance, CBs, walkie-talkie, ham radio or similar accessories) may cause extensive damage to the vehicle, compromise its safety, interfere with the vehicle's electrical system, or affect the validity of the BMW Limited Warranty. Visit your BMW center for additional information. ◀



Maintenance, replacement, or repair of the emission control devices and systems may be performed by any automotive repair establishment or individual using any certified automotive part. ◀

Symbol on vehicle parts



Indicates that you should consult the relevant section of this Owner's Manual for information on a particular part or assembly.

The following only applies to vehicles owned and operated in the US.

REPORTING SAFETY DEFECTS

If you believe that your vehicle has a defect which could cause a crash or could cause injury or death, you should immediately inform the National Highway Traffic Safety Administration (NHTSA) in addition to notifying BMW of North America, LLC, P.O. Box 1227, Westwood, New Jersey 07675-1227, Telephone (201) 307-4000.

If NHTSA receives similar complaints, it may open an investigation, and if it finds that a safety defect exists in a group of vehicles, it may order a recall and remedy campaign. However, NHTSA cannot become involved in individual problems between you, your BMW center, or BMW of North America, LLC.

To contact NHTSA, you may either call the Auto Safety Hotline toll-free at 1-800-424-9393 (or 366-0123 in Washington, D.C. area) or write to: NHTSA, U.S. Department of Transportation, Washington, D.C. 20590. You can also obtain other information about motor vehicle safety from the Hotline.



Overview

Controls and features

Operation, care
and maintenance

Owner service procedures

Advanced technology

Technical data

Index



Contents

Overview

- Cockpit 16
- Instrument cluster 18
- Indicator and warning lamps 22
- Multifunction steering wheel (MFL) 25
- Sports steering wheel 26
- Hazard warning flashers 27
- Warning triangle 27
- First-aid kit 27
- Refueling 28
- Fuel specifications 29
- Tire inflation pressure 29

Controls and features

- Locks and security systems:**
 - Keys 36
- Electronic vehicle immobilizer 37
- Opening and closing –
 - from the outside 38
- With the key 38
- With the remote control 39
- Opening and closing –
 - from the inside 42
- Luggage compartment lid/
 - Tailgate 43
- Rear window 43
- Luggage compartment 46
- Alarm system 47
- Electric power windows 49
- Sliding/Tilt sunroof 50

Adjustments:

- Seats 52
- Steering wheel 56
- Mirrors 56
- Seat, mirror and steering wheel memory 58
- Car Memory, Key Memory 60

Passenger safety systems:

- Safety belts 61
- Airbags 62
- Transporting children safely 66

Driving:

- Steering/Ignition lock 68
- Starting the engine 68
- Switching off the engine 69
- Parking brake 70
- Manual transmission 70
- Automatic transmission 72
- Automatic transmission with
 - Steptronic 75
- Indicator/Headlamp flasher 78
- Wiper/Washer system 78
- Rear window defroster 80
- Cruise control 81

Everything under control:

- Odometer, outside temperature display 83
- Tachometer 84
- Energy control 84
- Fuel gauge 84
- Coolant temperature gauge 85
- Service Interval Display 85
- Check Control 86
- Computer 89
- Multi-information display (MID) 91
- Digital clock in the MID 92
- Computer in the MID 95

- Controls and features**
- Technology for safety and driving convenience:**
 - Park Distance Control (PDC) 100
 - Automatic Stability Control plus Traction (ASC+T)/Dynamic Stability Control (DSC) 102
 - Tire Pressure Control (RDC) 103
 - Lamps:**
 - Parking lamps/Low beams 105
 - Instrument lighting 105
 - High beams/Parking lamps 106
 - Fog lamps 106
 - Interior lamps 106
 - Reading lamps 107
 - Controlling the climate for pleasant driving:**
 - Air conditioner 108
 - Automatic climate control 114
 - Seat heating 119
 - Steering wheel heating 120
 - Roller sun blind 120
 - Independent ventilation system 120
 - Cabin convenience:**
 - BMW Universal Transmitter 121
 - Glove compartment 124
 - Storage facilities 124
 - Cellular phone 125
 - Beverage holder 125
 - Ashtray, front 126
 - Cigarette lighter 126
 - Ashtray, rear 127
 - Loading and transporting cargo:**
 - Through-loading system 128
 - Ski bag 129
 - sport wagon:
 - Luggage compartment 132
 - Roll-up cover 132
 - Partition net 132
 - Storage areas in the luggage compartment 133
 - Cargo loading 136
 - Roof-mounted luggage rack 137
 - Operation, care and maintenance**
 - Special operating instructions:**
 - Break-in procedure 140
 - Driving notes 141
 - Catalytic converter 142
 - Antilock Brake System (ABS) 143
 - Disc brakes 144
 - Brake system 146
 - Winter operation 146
 - Power steering 148
 - Level control system 148
 - Cellular phone 149
 - Radio reception 149
 - Wheels and tires:**
 - Tire inflation pressure 150
 - Tire condition 150
 - Tire replacement 151
 - Tire rotation 152
 - Wheel and tire combinations 153
 - Winter tires 154
 - Snow chains 155
 - Approved wheel and tire specifications 156

Contents

Operation, care and maintenance

Under the hood:

- Hood [159](#)
- Engine compartment [160](#)
- Washer fluids [164](#)
- Washer nozzles [164](#)
- Engine oil [165](#)
- Coolant [167](#)
- Brake fluid [168](#)
- Vehicle Identification Number [169](#)

Care and maintenance:

- The BMW Maintenance System [170](#)
- Caring for your car [171](#)
- Airbags [176](#)
- Vehicle storage [176](#)

Laws and regulations:

- Technical modifications [177](#)
- California Proposition 65 Warning [177](#)
- OBD interface socket [178](#)

Owner service procedures

Replacement procedures:

- Onboard tool kit [182](#)
- Wiper blades [182](#)
- Lamps and bulbs [183](#)
- Changing a wheel [190](#)
- Battery [193](#)
- Fuses [196](#)

In case of electrical malfunction:

- Fuel filler door [198](#)
- Sliding/Tilt sunroof [198](#)
- Tailgate [199](#)

Assistance, giving and receiving:

- Jump-starting [200](#)
- Towing the vehicle [201](#)

Advanced technology

- Airbags [206](#)
- Adaptive Transmission Control (ATC) [207](#)
- Automatic Stability Control plus Traction (ASC+T)/Dynamic Stability Control (DSC) [208](#)
- BMW active seat [210](#)
- Safety belt tensioner [210](#)
- DSP sound system [211](#)
- Mirrors with automatic dimmer [211](#)
- Rain sensor [212](#)
- Tire Pressure Control (RDC) [213](#)
- Integrated rear suspension [214](#)
- Level control system [214](#)
- Xenon lamps [215](#)

Technical data

- Engine specifications [218](#)
- Dimensions [219](#)
- Weights [221](#)
- Capacities [223](#)
- Electrical system [224](#)
- Drive belts [224](#)

Index

- Everything from A to Z [228](#)





Cockpit [16](#)
 Instrument cluster [18](#)
 Indicator and warning lamps [22](#)
 Multifunction steering wheel
 (MFL) [25](#)
 Sports steering wheel [26](#)
 Hazard warning flashers [27](#)
 Warning triangle [27](#)
 First-aid kit [27](#)
 Refueling [28](#)
 Fuel specifications [29](#)
 Tire inflation pressure [29](#)

Overview

Controls and features

Operation, care and maintenance

Owner service procedures

Advanced technology

Technical data

Index

16 Cockpit

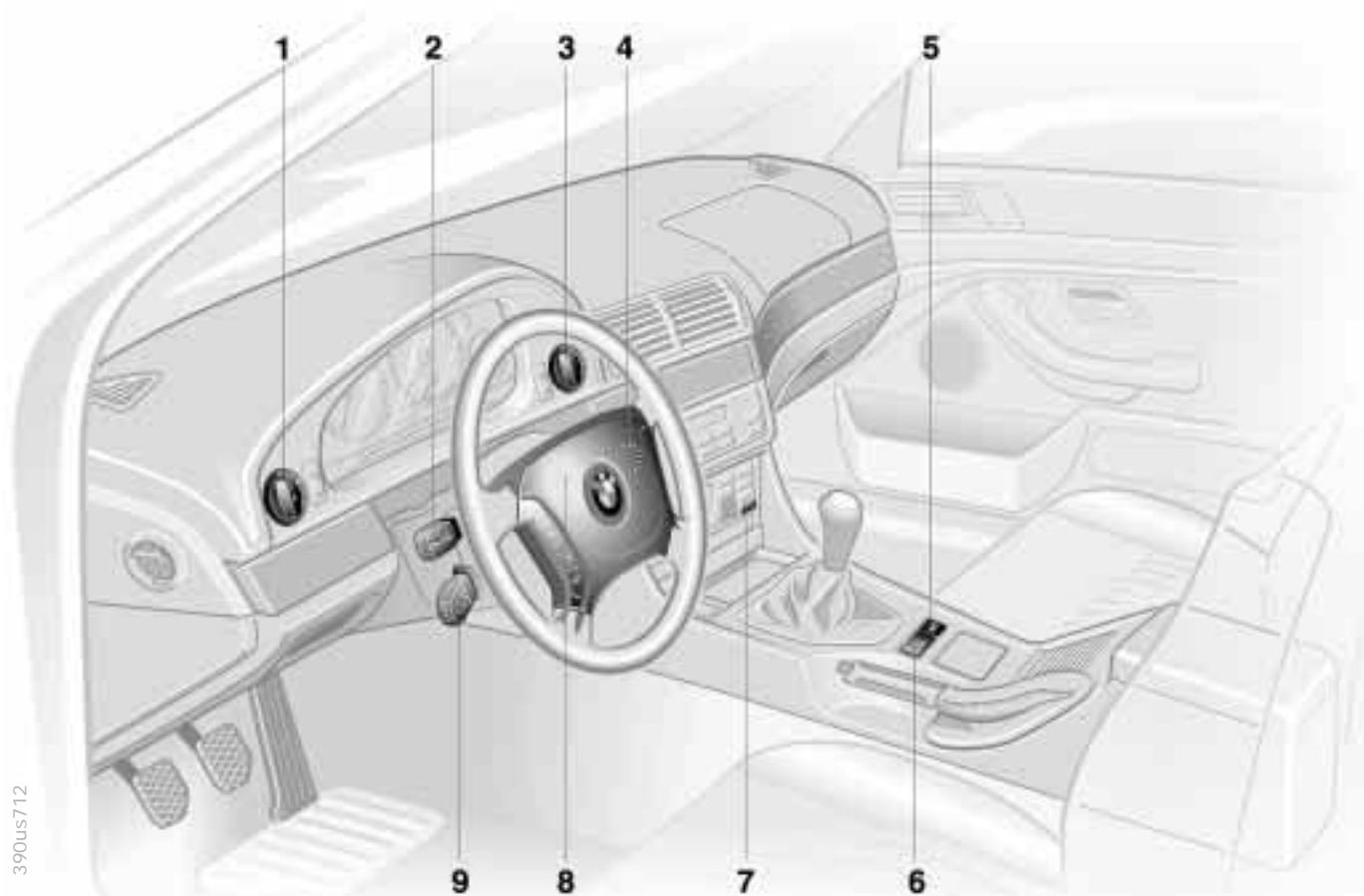

Cockpit

- 1 Parking lamps/Low beams [105](#)
- 2 ▷ Turn signal [78](#)
 - ▷ Parking lamps [106](#)
 - ▷ High beams [106](#)
 - ▷ Headlamp flasher [78](#)
 - ▷ Computer [89](#)
- 3 Fog lamps [106](#)
- 4 Wiper/Washer system [78](#)
- 5 Central locking system [38](#)
- 6 Hazard warning flashers [27](#)
- 7 Rear window defroster [80](#)
- 8 Horn [25, 26](#)
- 9 Adjusting the steering wheel [56](#)

18 Instrument cluster



Instrument cluster

There are two versions, depending on the equipment on your vehicle.

- 1 Fuel gauge with indicator lamp for fuel reserve [84](#)
- 2 Indicator lamp for turn signals [24](#)
- 3 Speedometer
- 4 Indicator lamp for high beams [24](#)
- 5 Tachometer and Energy Control [84](#)
- 6 Coolant thermometer with "Coolant temperature too high" warning lamp [85](#)
- 7 Indicator and warning lamps for:
 - ▷ Parking brake/Brake hydraulic system, Dynamic Brake Control (DBC)* [22](#), [23](#)
 - ▷ Antilock Brake System (ABS) [23](#)
 - ▷ Brake pads [23](#)
 - ▷ Tire Pressure Control (RDC)* [23](#)
 - ▷ Airbags [23](#)
 - ▷ Automatic transmission* [23](#)
 - ▷ Please fasten safety belts [23](#)
 - ▷ Cruise control [24](#)
- 8 Selector lever and program display for automatic transmission* [72](#), [75](#)
- 9 Service Interval Display [85](#)
- 10 Display for the computer (operation via the turn signal lever, refer to page 89):
 - ▷ Outside temperature
 - ▷ Average fuel consumption
 - ▷ Cruising range
 - ▷ Average speed
- 11 Indicator lamp for Automatic Stability Control plus Traction (ASC+T)/Dynamic Stability Control (DSC)* [24](#)
- 12 Indicator lamp for level control system* [23](#)
- 13 Odometer and trip odometer [83](#)
- 14 Indicator for Check Control [86](#)
- 15 Reset button for trip odometer [83](#)
- 16 Indicator and warning lamps for:
 - ▷ Fog lamps [24](#)
 - ▷ Battery charge current [22](#)
 - ▷ Engine oil level/Engine oil pressure [22](#), [23](#)
 - ▷ Engine electronics [24](#)
 - ▷ Service Engine Soon [24](#)

20 Instrument cluster*

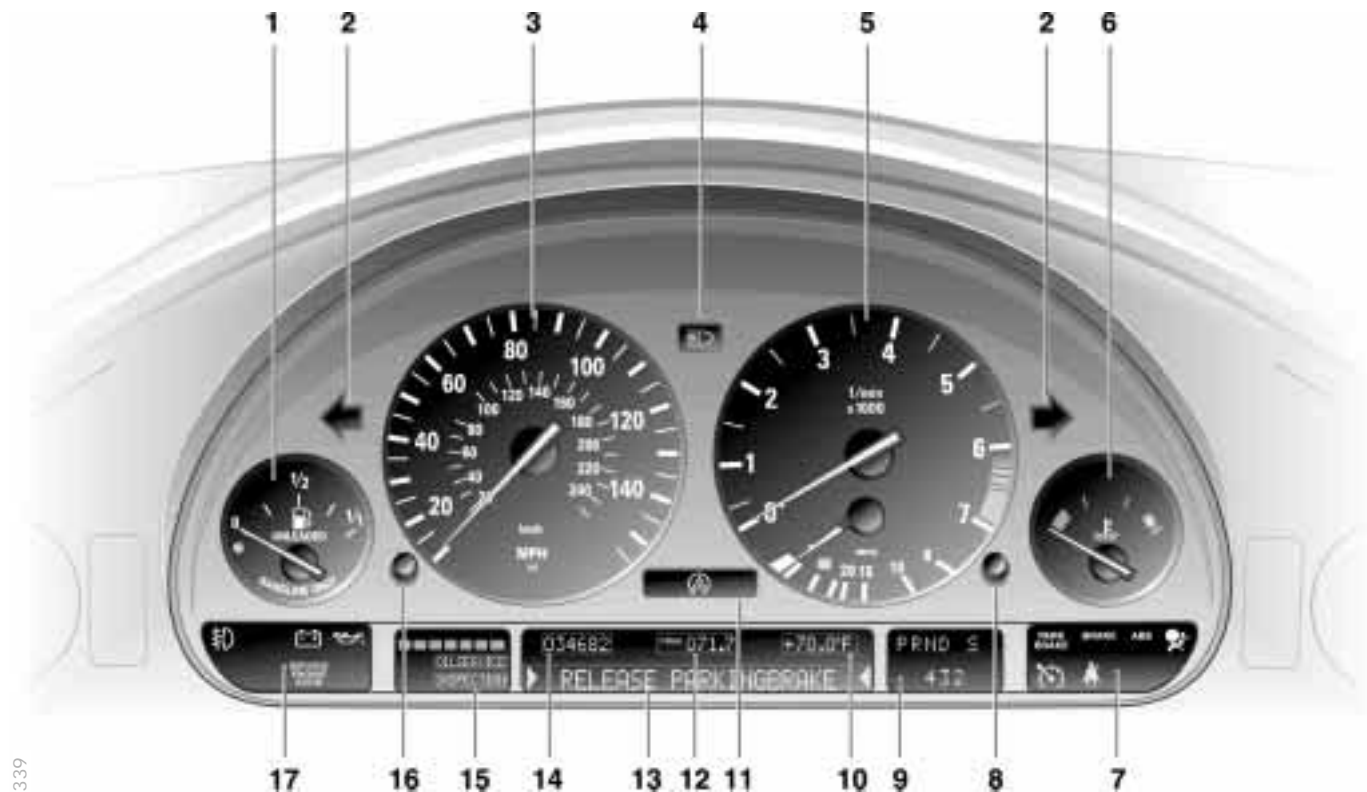

Instrument cluster*

There are two versions, depending on the equipment on your vehicle.

- 1 Fuel gauge with indicator lamp for fuel reserve [84](#)
- 2 Indicator lamp for turn signals [24](#)
- 3 Speedometer
- 4 Indicator lamp for high beams [24](#)
- 5 Tachometer and Energy control [84](#)
- 6 Coolant temperature gauge [85](#)
- 7 Indicator and warning lamps for:
 - ▷ Parking brake [23](#)
 - ▷ Brake hydraulic system, Dynamic Brake Control (DBC)* [22](#), [23](#)
 - ▷ Antilock Brake System (ABS) [23](#)
 - ▷ Airbags [23](#)
 - ▷ Please fasten safety belts [23](#)
 - ▷ Cruise control [24](#)
- 8 CHECK button [86](#)
- 9 Selector lever and program display for automatic transmission* [72](#), [75](#)
- 10 Outside temperature display [83](#)
- 11 Indicator lamp for Automatic Stability Control plus Traction (ASC+T)/Dynamic Stability Control (DSC)* [24](#)
- 12 Trip odometer [83](#)
- 13 Check Control display [86](#)
- 14 Odometer [83](#)
- 15 Service Interval Display [85](#)
- 16 Reset button for trip odometer [83](#)
- 17 Indicator and warning lamps for:
 - ▷ Fog lamps [24](#)
 - ▷ Battery charge current [22](#)
 - ▷ Engine oil pressure [22](#)
 - ▷ Service Engine Soon [24](#)

22 Indicator and warning lamps

Technology that monitors itself

Many of the systems of your BMW monitor themselves automatically, both during engine starts and while you are driving. Indicator and warning lamps that are identified by "●" are tested for proper functioning whenever the ignition key is turned. They each light up once for different periods of time.

If a fault should occur in one of these systems, the corresponding lamp does not go out after the engine is started or it lights up while the vehicle is moving. You will see how to react to this below.

Red: stop immediately



Battery charge current ●
The battery is no longer being charged. There is a malfunction of the alternator V-belt or in the charging circuit of the alternator. Please contact the nearest BMW center.



If the ribbed V-belt is defective, do not continue driving. The engine could be damaged due to overheating. If the ribbed V-belt is defective, increased steering effort is also required. ◀



Engine oil pressure ●
Comes on while the engine is running and the "STOP!ENGINE OILPRESS" message appears in the Check Control: stop vehicle immediately and switch off engine. Check level of oil in engine, top up as required. If oil level is correct: please contact the nearest BMW center.



Do not continue driving. The engine could be damaged because of inadequate lubrication. ◀



Tire Pressure Control (RDC)* ●
In addition, there is an acoustical warning signal: a tire failure has occurred. Reduce vehicle speed immediately and stop the vehicle. Avoid hard brake applications. Do not oversteer. For additional information: refer to page 103.



**Parking brake*,
brake hydraulic system ●**
Comes on when you engage the parking brake. For additional information: refer to page 70.

Comes on although the parking brake is released: have the brake fluid level checked. Before driving further, be sure to read the notes on pages 146 and 168.

Also comes on with the message "CHECK BRAKE PADS" in the Check Control.



**Parking brake* warning lamp/
Brake hydraulic system for
Canadian models.**

Red: an important reminder



Parking brake*

Comes on when you engage the parking brake.

For additional information: refer to page [70](#).



Parking brake* warning lamp for Canadian models.



Please fasten safety belts ●

Together with an acoustic signal or a message* in the Check

Control. Comes on until the safety belts are fastened. For additional information on safety belts: refer to page [61](#).



Airbags ●

Please have the system inspected by your BMW center.

For additional information: refer to page [62](#).

Yellow: check as soon as possible



Antilock Brake System (ABS) ●

ABS has been deactivated in response to system malfunction.

Conventional braking efficiency is available without limitations. Please have the system inspected by your BMW center.

For additional information: refer to page [143](#).



Antilock Brake System (ABS)

warning lamp for Canadian models.



Engine oil level*

Comes on while driving: the oil level is at the absolute minimum; refill as soon as possible. Do not drive more than approx. 30 miles (50 km) until you add oil.

For additional information: refer to page [165](#).



Engine oil level*

Comes on after the engine has been shut off: add oil at the earliest opportunity (when you stop to refuel).

For additional information: refer to page [165](#).



Automatic transmission*

Because of a malfunction, the automatic transmission shifts only in the emergency program. Please consult the nearest BMW center. For additional information: refer to pages [74](#), [77](#).



Brake pads* ●

Have the brake pads checked. For additional information: refer to page [146](#).



Dynamic Brake Control

(DBC)* ●
Fault in the DBC system. Conventional braking efficiency is available without limitations. For additional information: refer to page [145](#).



Dynamic Brake Control (DBC)

warning lamp for Canadian models.



Tire Pressure Control (RDC)* ●

Check the tire inflation pressure. Refer to pages [29](#), [103](#).



Level control system* ●

The level control system is inactive. Please consult the nearest BMW center. For additional information: refer to page [148](#).

24 Indicator and warning lamps



Automatic Stability Control plus Traction (ASC+T)/Dynamic Stability Control (DSC)* ●

The ASC+T/DSC has been switched off or has been deactivated because of a malfunction. In the event of a malfunction, have the system checked by your BMW center.

For additional information: refer to page [102](#).



Engine electronics*

There is a fault in the engine's electronic control system. The electronics allow for continued driving with reduced engine output or rpms. Please have the system inspected by your BMW center.



Service Engine Soon ●

If the indicator lamp comes on either continuously or intermittently, this indicates a fault in the emissions-related electronic systems.

Although the vehicle remains operational, you should have the systems checked by your BMW center at the earliest possible opportunity.

For additional information: refer to page [178](#).



Service Engine Soon warning lamp for Canadian models.

Green: for your information



Turn signal

Flashes when the turn signals are in operation. Rapid flashing indicates a system malfunction. For additional information: refer to page [78](#).



Cruise control

Lights up when the cruise control is activated. Available for operation via the multifunction steering wheel.

For additional information: refer to page [81](#).



Fog lamps

Lights up whenever you switch on the fog lamps.

For additional information: refer to page [106](#).

Blue: for your information



High beams

Lights up when the high beams are on or the headlamp flasher is actuated.

For additional information: refer to pages [78](#) and [106](#).

Multifunction steering wheel (MFL)

The controls integrated in the multifunction steering wheel (MFL) are provided so that you can operate a number of accessories quickly and without being distracted from traffic conditions. You may operate:

- ▷ Selected functions of the radio as well as the CD and cassette modes,
- ▷ the recirculated air mode of the air conditioner or
- ▷ the steering wheel heater*,
- ▷ the cruise control,
- ▷ selected cellular phone functions and
- ▷ the voice recognition*

 In order to operate a system via the MFL, the corresponding systems must be switched on. ◀

The illustration shows the maximum possible number of controls, corresponding to a full range of optional equipment. Refer to the individual accessory manuals for more detailed descriptions.



- 1 Press briefly:
Receive a phone call, initiate dialing, terminate a call.
Press longer:
Turn voice recognition on and off
- 2 Radio/Cellular phone: select
- 3 Radio/Cellular phone: scan backward or scan station keys or scroll through the phone listings.
Rewind on the CD and cassette modes
- 4 Radio/Cellular phone: volume
- 5 Radio/Cellular phone: scan forward or scan station keys or scroll through the phone listings.
Fast forward on the CD and cassette modes
- 6 Horn: the entire surface
- 7 Cruise control: activate stored setting (resume)
- 8 Cruise control: store and accelerate (+); decelerate and store (-)
- 9 Cruise control: activate/interrupt/deactivate
- 10 Recirculated-air mode and AUC or steering wheel heater: switch on and off

26 Sports steering wheel*

The controls integrated in the sports steering wheel are provided so that you can operate a number of accessories quickly and without being distracted from traffic conditions. You may operate:

- ▷ Selected radio functions as well as the CD and cassette modes,
- ▷ the cruise control,
- ▷ selected cellular phone functions and
- ▷ the voice recognition*

 In order to operate a system via the sports steering wheel, the corresponding systems must be activated. ◀

The illustration shows the maximum possible number of controls, corresponding to a full range of optional equipment. Refer to the individual accessory manuals for more detailed descriptions.



- 1 Radio/Cellular phone: select
- 2 Press briefly:
Receive a phone call, initiate dialing, and terminate a call.
Press longer:
Turn voice recognition on and off
- 3 Radio/Cellular phone: volume
- 4 Radio/Cellular phone: scan backward or scan station keys or scroll through the phone listings.
Rewind on the CD and cassette modes
- 5 Radio/Cellular phone: scan forward or scan station keys or scroll through the phone listings.
Fast forward on the CD and cassette modes
- 6 Horn: the entire surface
- 7 Cruise control: resume stored setting
- 8 Cruise control: store and accelerate (+); decelerate and store (-)
- 9 Cruise control: activate/interrupt/deactivate

Hazard warning flashers



The button flashes rhythmically when the hazard warning flashers are on.

To help you locate the switch in an emergency, the button is also illuminated whenever the car's headlamps are on.

Warning triangle*

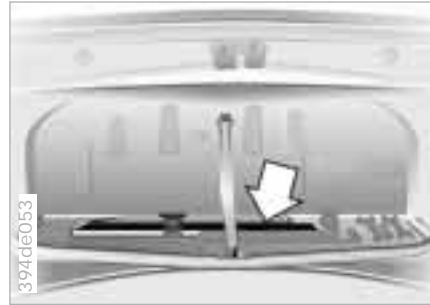

The hazard warning triangle is quickly available, stored in the onboard tool kit mounted on the inside of the luggage compartment lid/tailgate.

To open the container, loosen the wing screw.

 Comply with legal requirements which cover the availability of a hazard warning triangle in the car. ◀

First-aid kit*



The first-aid kit is located under the front passenger's seat.

To remove: lift the release lever on the front (arrow) and pull the first-aid kit forward out of its support.

To store: place the back of the kit into the support, then push back until the lever engages.

 Some of the articles in the first-aid kit may be used within a limited time only. For this reason, check the expiration dates of each of the items regularly, and replace any whose expiration dates have passed. You can acquire replacements in any drugstore or pharmacy. Comply with legal requirements which cover availability of a first-aid kit in your vehicle. ◀

28 Refueling

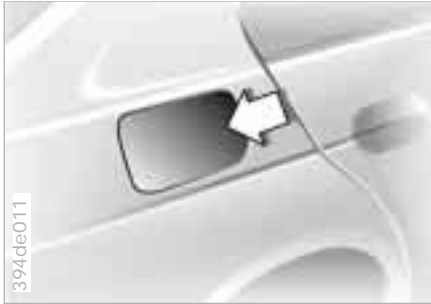

Fuel filler door

 Before refueling, shut the engine off. If the engine is running, fuel cannot be filled into the tank and the Service Engine Soon lamp may come on. ◀

To open the filler door, press on the front edge.

To unlock the filler door if the central locking system fails, refer to page 198.

 When handling fuels, comply with all of the applicable safety precautions and regulations pertaining to fuels.

Never carry spare fuel containers in your vehicle. Whether empty or full, these containers can leak, cause an explosion, or lead to fire in the event of a collision. ◀



Simple and friendly to the environment

 Open the filler cap carefully to prevent fuel from spraying out. Fuel spray may cause injury. Do not top off. Topping off may cause fuel spillage. ◀

Keep the filler cap in the bracket attached to the fuel filler door.

When refueling, insert the filler nozzle completely into the filler pipe. Pulling the nozzle out of the pipe during refueling

- ▷ results in premature pump shutoff
- ▷ and will reduce the effect of the vapor recovery system on the pump.

As long as the filler nozzle is used properly, the fuel tank is full whenever the nozzle shuts off the first time.

Tank capacity: refer to page [223](#).

 Close the filler cap carefully after refueling until a "click" is heard. While closing, be sure not to squeeze the strap which is fastened to the cap. A loose or missing cap will activate the message "CHECK FILLER CAP" in the Check Control* or the Service Engine Soon lamp. ◀

Fuel specifications

The engine uses lead-free gasoline only.

Required fuel:

- ▷ Premium Unleaded Gasoline, min. 91 AKI
AKI = Anti Knock Index

 Do not use leaded fuels. The use of leaded fuels will cause permanent damage to the system's oxygen sensor and the catalytic converter. ◀

Tire inflation pressure



The inflation pressures are indicated on a sticker attached to the B-pillar behind the driver's door (visible with door open).

Check tire pressures

All pressure specifications are indicated in psi (kilopascal) for tires at ambient temperature (refer also to the next pages).

For vehicles with Tire Pressure Control (RDC)*:

After a correction of the tire inflation pressure, reactivate the system. Refer to page [103](#).



 Check tire inflation pressures regularly – at least every two weeks and before beginning a longer trip. Incorrect tire pressure can lead to tire damage and accidents. Check the inflation pressure of the spare tire also. Inflate the spare tire to the highest inflation of any tire on your vehicle. ◀

Comply with tire approval specifications



The inflation pressures in the table apply to tires from BMW approved manufacturers. Your BMW center is familiar with these pressures. Higher pressures may be specified for tires from other manufacturers. You will find a list of approved tires beginning on page [156](#).

Your vehicle is equipped with tires that meet US standards as well as European standards. We recommend the exclusive use of BMW approved tires.

30 Tire inflation pressure

sedan	Tires				
	All pressure specifications in the table are indicated in psi (kilopascal) with cold tires (cold = ambient temperature)				
	225/60 R 15 96 H M+S	-	-	33 (230)	41 (280)
	225/55 R 16 95 H M+S			(US/CDN)	
	225/60 R 15 96 W				
	225/55 R 16 95 W				
	235/45 R 17 94 W/Y	29 (200)	33 (230)	33 (230)	41 (280)
525i	205/65 R 15 94 Q M+S		(outside US/CDN)		
	225/60 R 15 96 Q M+S				
	225/55 R 16 95 Q M+S				
	235/45 R 17 94 Q M+S				
	Front: 235/45 R 17 94 W/Y				
	Rear: 255/40 R 17 94 W/Y				
	225/55 R 16 95 H M+S	-	-	33 (230)	41 (280)
	225/55 R 16 95 W			(US/CDN)	
	235/45 R 17 94 W/Y				
530i	225/55 R 16 95 Q M+S	29 (200)	33 (230)	33 (230)	41 (280)
	235/45 R 17 94 Q M+S		(outside US/CDN)		
	Front: 235/45 R 17 94 W/Y				
	Rear: 255/40 R 17 94 W/Y				

Tire inflation pressure

sedan	Tires All pressure specifications in the table are indicated in psi (kilopascal) with cold tires (cold = ambient temperature)				
	225/55 R 16 95 W 235/45 R 17 94 W/Y	35 (240)	39 (270)	41 (280)	48 (330)
540i	Front: 235/45 R 17 94 W/Y Rear: 255/40 R 17 94 W/Y	35 (240)	-	41 (280)	-
	225/55 R 16 95 Q/T/H M+S 235/45 R 17 94 Q/T/H M+S	-	39 (270)	-	48 (330)
	225/55 R 16 95 Q/T/H M+S 235/45 R 17 94 Q/T/H M+S	30 (210)	35 (240)	36 (250)	44 (300)
540iA	225/55 R 16 95 H M+S 225/55 R 16 95 W 235/45 R 17 94 W/Y	30 (210)	35 (240)	36 (250)	44 (300)
	225/55 R 16 95 Q M+S 235/45 R 17 94 Q M+S				
	Front: 235/45 R 17 94 W/Y Rear: 255/40 R 17 94 W/Y	30 (210)	-	36 (250)	-
		-	35 (240)	-	44 (300)

32 Tire inflation pressure

sport wagon	Tires All pressure specifications in the table are indicated in psi (kilopascal) with cold tires (cold = ambient temperature)					
525i	225/55 R 16 95 H M+S 225/60 R 15 96 H M+S 225/60 R 15 96 W 225/55 R 16 95 W 235/45 R 17 94 W/Y	30 (210)	35 (240)	36 (250)	44 (300)	
	225/60 R 15 96 Q M+S 225/55 R 16 95 Q M+S 235/45 R 17 94 Q M+S	33 (230)	38 (260)	39 (270)	46 (320)	
	540i	225/55 R 16 95 H M+S 225/55 R 16 95 W 235/45 R 17 94 W/Y	30 (210)	35 (240)	36 (250)	44 (300)
		225/55 R 16 95 Q M+S 235/45 R 17 94 Q M+S	33 (230)	38 (260)	39 (270)	46 (320)

Locks and security systems:

- Keys 36
- Electronic vehicle immobilizer 37
- Central locking system 38
 - Opening and closing –
 - from the outside 38
 - With the key 38
 - With the remote control 38
 - Opening and closing –
 - from the inside 42
- Luggage compartment lid/
Tailgate 43
- Rear window 44
- Luggage compartment 46
- Alarm system 47
- Electric power windows 49
- Sliding/Tilt sunroof 50

Adjustments:

- Seats 52
- Steering wheel 56
- Mirrors 56
- Seat, mirror and steering wheel memory 58
- Car Memory, Key Memory 60

Passenger safety systems:

- Safety belts 61
- Airbags 62
- Transporting children safely 66

Driving:

- Steering/Ignition lock 68
- Starting the engine 68
- Switching off the engine 69
- Parking brake 70
- Manual transmission 70
- Automatic transmission 72
- Automatic transmission with
Steptronic 75
- Indicator/Headlamp flasher 78
- Wiper/Washer system 78
- Rear window defroster 80
- Cruise control 81

Everything under control:

- Odometer, outside temperature display 83
- Tachometer 84
- Energy control 84
- Fuel gauge 84
- Coolant temperature gauge 85
- Service Interval Display 85
- Check Control 86
- Computer 89
- Multi-information display (MID) 91
 - Digital clock in the MID 92
 - Computer in the MID 95

Technology for safety and driving convenience:

Park Distance Control (PDC) 100

Automatic Stability Control plus Traction (ASC+T)/Dynamic Stability Control (DSC) 102

Tire Pressure Control (RDC) 103

Lamps:

Parking lamps/Low beams 105

Instrument lighting 105

High beams/Parking lamps 106

Fog lamps 106

Interior lamps 106

Reading lamps 107

Controlling the climate for pleasant driving:

Air conditioner 108

Automatic climate control 114

Seat heating 119

Steering wheel heating 120

Roller sun blind 120

Independent ventilation system 120

Cabin convenience:

BMW Universal Transmitter 121

Glove compartment 124

Storage facilities 124

Cellular phone 125

Beverage holder 125

Ashtray, front 126

Cigarette lighter 126

Ashtray, rear 127

Loading and transporting cargo:

Through-loading system 128

Ski bag 129

sport wagon:

Luggage compartment 132

Roll-up cover 132

Partition net 132

Storage areas in the luggage compartment 133

Cargo loading 136

Roof-mounted luggage rack 137

Controls and features**Operation, care and maintenance****Owner service procedures****Advanced technology****Technical data****Index**

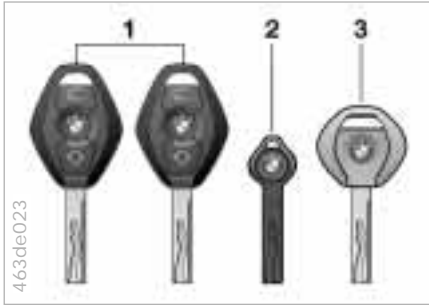

1 The master keys with remote control determine the functions of the Key Memory. Refer to page 60.

 There is an extended-life battery in every master key that is charged automatically in the ignition lock as you drive.

For this reason, if you have a master key that is otherwise not used, use that key approximately once every year while driving for an extended period to charge the battery. Refer also to page 39. ◀

2 Spare key for storage in a safe place such as in your wallet. This key is not intended for continuous use.

3 Door and ignition key

The locks for the luggage compartment lid/tailgate, rear backrest and glove compartment cannot be operated with this key. This is useful for valet parking, for instance.

Replacement keys

Replacement keys are available exclusively through your authorized BMW center. Your BMW center is obligated to ensure that a person requesting a key is authorized to do so since the keys belong to a security system (refer to "Electronic vehicle immobilizer" on page 37).

 If possible, take all of the master keys that belong to the vehicle with you when you pick up your replacement key. Whenever you receive a new replacement key, turn that key to position 2 in the ignition lock once (ignition switched on) and then back. This allows the electronic vehicle immobilizer to "learn" the new key. ◀

Electronic vehicle immobilizer



The key to security

Your BMW is equipped with a passive anti-theft system. This electronic immobilization system is designed to reduce the susceptibility of your vehicle to theft by making it impossible to start the engine using any means other than the special keys furnished with the vehicle. Your BMW center can cancel the electronic system authorization for individual keys (in the event of loss, for instance). A deactivated key can no longer be used to start the engine.

How the electronics work

At the heart of this system is an electronic chip which is integrated into the key. The lock mechanism itself is actually a dual-function device, simultaneously serving as a communications interface designed to allow the security system to maintain a continuous stream of variable, vehicle-specific signals with the electronic circuitry in the key. The system will not release the ignition, fuel injection and starter unless it recognizes an "authorized" key.

 Force applied to the key can damage the integrated electronic circuitry. A damaged key can no longer be used to start the engine. ◀

The concept

The central locking system is ready for operation as soon as you close the front doors. The system engages and releases the locks on the

- ▷ doors
- ▷ luggage compartment lid/tailgate and rear window*
- ▷ fuel filler door.

The central locking system can be operated

- ▷ from outside via the driver's door lock as well as via the remote control
- ▷ from inside via the central locking system button.

The fuel filler door remains unlocked when you activate the system from inside the vehicle (refer to page 42). The anti-theft system is automatically armed whenever you activate the central locking system from outside the vehicle. The alarm system is also activated or deactivated.

If looked from inside, the central locking system unlocks automatically (only those doors which were not locked separately with the safety lock buttons) in the event of an accident. Refer to page 42. In addition, the hazard warning flashers and interior lamps come on.

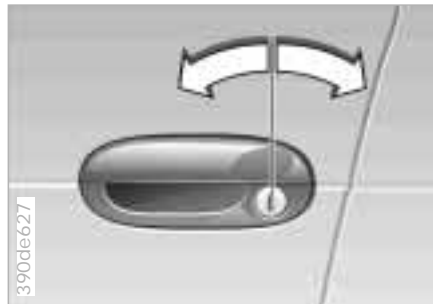
**With the key**

One turn of the key in the driver's door lock unlocks the driver's door only. Turning the key a second time unlocks all of the remaining doors, the luggage compartment lid/tailgate and the fuel filler door.



You can have a signal set as an acknowledgment message that the vehicle is closed correctly. ◀

Convenience operation

You can also operate the windows and sliding/tilt sunroof via the door lock.

- ▷ To open: with the door closed, turn the key to the "Unlock" position and hold it.
- ▷ To close: with the door closed, turn the key to the "Lock" position and hold it.



Watch the closing process carefully and be sure that no one is trapped by the closing motion. The windows/sunroof stop moving immediately when you release the key. ◀

Manual operation

(in the event of an electrical malfunction)

Turn the key all the way to the left or right to unlock/lock the door.

Opening and closing – from the outside

With the remote control

The remote control makes opening and locking the doors of your vehicle very convenient. Furthermore, it provides three additional functions which you can only execute via the remote control:

- ▷ To switch on interior lamps, refer to page 40
With this function, you can also "search for" your vehicle, when parked in an underground garage, for instance.
- ▷ To open the luggage compartment/tailgate, refer to page 41
The luggage compartment lid/tailgate will open slightly, regardless of whether it was previously locked or unlocked.
- ▷ Panic mode
In case of danger, you can trigger the alarm.

When the vehicle is unlocked, the anti-theft system is simultaneously deactivated, the alarm system is disarmed and the interior lamps are switched on. Locking the vehicle activates the anti-theft and alarm systems and switches the interior lamps off.

 You can have a signal set as an acknowledgment message that the vehicle is closed correctly. ◀



Master keys

Keys with a transmitter for remote control are master keys. Refer to page 36.

 Since children might be able to lock the doors from the inside, take the vehicle's keys with you so that the vehicle can be opened again from the outside at any time. ◀

 Master keys that are used repeatedly are always ready for operation, since the battery in the key is charged automatically in the ignition lock as you drive.

If it is no longer possible to unlock the vehicle via the remote control, the battery is discharged. Use this key while driving for an extended period in order to charge the battery. Refer also to page 36.

To prevent unauthorized use of the remote control, surrender only the door and ignition key 3 or the spare key 2 (refer to page 36) when leaving the vehicle for valet parking, for example. In the event of a system malfunction, please contact your BMW center. You can also obtain replacement keys there. ◀

40 Opening and closing – from the outside



463de025

Unlocking and convenience opening mode

To release: press button 1.

Press the button once to unlock the driver's door only; press a second time to unlock all remaining doors as well as the luggage compartment/tailgate and fuel filler door.

Convenience opening mode: press and hold button 1. The windows and the sliding/tilt sunroof are opened.



463de027

To lock and secure

Press button 2.



463de027

Deactivate the alarm system tilt sensor and interior motion sensor

After locking the vehicle press button 2 again.

For additional information: refer to page [48](#).

To switch on the interior lamps

With the vehicle locked, press button 2.

Opening and closing – from the outside



To open the luggage compartment lid/tailgate

Press button 3.

The luggage compartment lid/tailgate opens slightly, regardless of whether it was previously locked or unlocked.

 Before and after a trip, be sure that the luggage compartment lid/tailgate has not been opened unintentionally. ◀

Panic mode

By pressing and holding button 3 for two to five seconds, you can trigger the alarm system if there is an impending danger (the system must be armed).

The alarm is deactivated by pressing button 1.

External systems

External systems or devices may cause local interference in the functions of the remote control.

If this should occur, you can unlock and lock the vehicle via the door lock with a master key.

For US owners only

The transmitter and receiver units comply with part 15 of the FCC (Federal Communication Commission) regulations. Operation is governed by the following:

FCC ID: LX8EWS
LX8FZVS
LX8FZVE

Compliance statement:

This device complies with part 15 of the FCC Rules. Operation is subject to the following two conditions:

- ▷ This device may not cause harmful interference, and
- ▷ this device must accept any interference received, including interference that may cause undesired operation.

 Any unauthorized modifications to these devices could void the user's authority to operate the equipment. ◀

42 Opening and closing – from the inside



You can operate the central locking system with this button when the driver's door is closed. With this button, only the doors, the luggage compartment lid/tailgate and rear window are unlocked or locked. The anti-theft system is not activated. Also, the fuel filler door remains unlocked to allow refueling.

 The central locking system can be locked automatically as soon as you begin to drive if you desire. You may also have this adjusted so that it is specific to keys. ◀



If only the driver's door was unlocked from the outside and you press the button

- ▷ all other doors, the luggage compartment lid/tailgate and rear window and the fuel filler door will be
- ▷ unlocked if the driver's door is open
- ▷ the driver's door will be locked again when it is closed. ◀

To unlock and open the doors

- ▷ Either unlock the doors together with the button for the central locking system and then pull the door handle above the armrest or
- ▷ pull the release handle for each door twice: the first pull unlocks the door, and the second one opens it.

To engage locks

- ▷ Use the central locking button to lock all doors at once, or
- ▷ press the individual door lock buttons down. As an added design feature to prevent the driver from being inadvertently locked out of the vehicle, the driver's door lock button will not engage as long as the door is open.



When the vehicle is moving, do not lock the doors with their lock buttons since doors locked in this manner would not open automatically in the event of an accident.

Children might be able to lock the doors from the inside. For this reason, you should always remove the key and take it with you to be sure that you will be able to unlock the car from the outside at all times. ◀

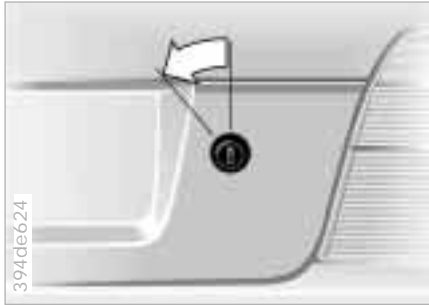

Lock – sedan only

Only the master keys (refer to page 36) fit in the lock of the luggage compartment lid.

Opening separately

Turn the master key to the left in the luggage compartment lock clear to the stop – the luggage compartment lid will open slightly.

The luggage compartment is locked again as soon as you close the lid.

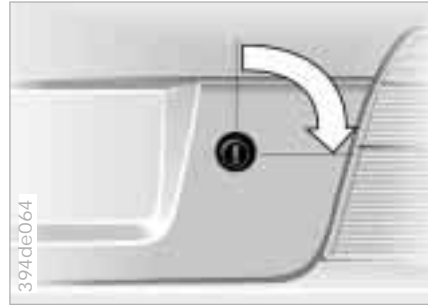

Secure separately

Turn the master key to the right past the resistance point and then pull it out in the horizontal position.

This locks the luggage compartment lid and disconnects it from the central locking system. This feature can be used to prevent unauthorized access to the luggage compartment when you hand over the door and ignition key (refer to page 36) for valet parking, for instance.

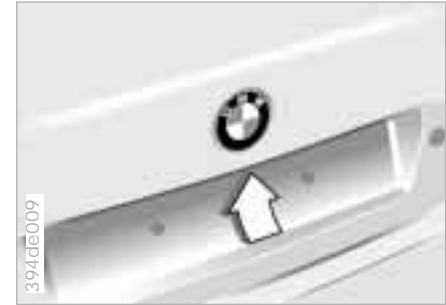

To open from the outside

Press the button (arrow): the luggage compartment lid/tailgate opens slightly.

Manual operation

(in the event of an electrical malfunction)

sedan:

Turn the master key to the left in the luggage compartment lock clear to the stop – the luggage compartment lid will open slightly.

The luggage compartment is locked again as soon as you close the lid.

sport wagon:

Refer to page 199.

44 Luggage compartment lid/Tailgate



Opening from inside the car

You can use this button to open the luggage compartment lid/tailgate when the vehicle is stationary (not possible, if the luggage compartment lid/tailgate has been locked separately).



When the tailgate of the sport wagon is opened, the clearance from the ground to the upper edge is more than 6.6 ft (two meters). Please keep this in mind when opening the tailgate (in a garage, for example). ◀

For additional details concerning the luggage compartment, please refer to "Luggage compartment – sport wagon" beginning on page [132](#).

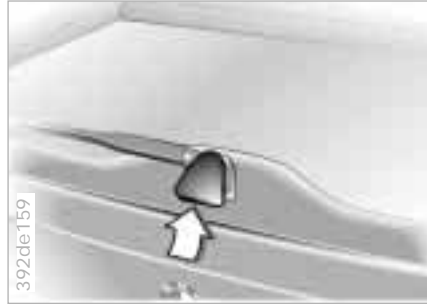

Rear window – sport wagon

Small items can be loaded or unloaded quickly if the rear window is opened separately.

Press the button (arrow): the rear window opens slightly. It can now be tilted up.

Push the window down to close it.



If pointed or sharp-edged objects could strike the rear window while driving, be sure to provide protection around all edges. If you do not do this, the heating conductors of the rear window could be damaged. ◀

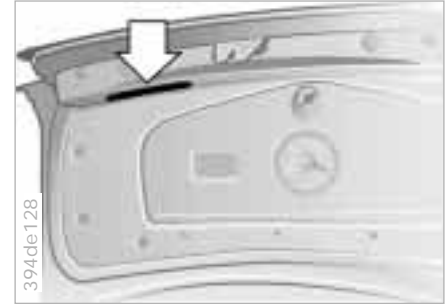

Closing – sedan

The handle recess (arrow) next to the lock mechanism is designed to assist you in closing the luggage compartment lid.

Luggage compartment lid/Tailgate

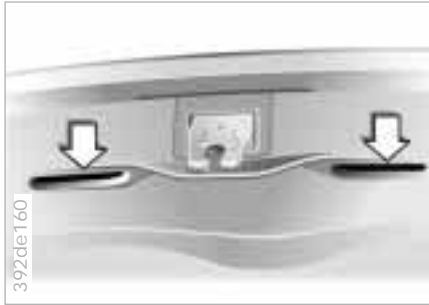

Closing – sport wagon

You can pull the tailgate down by placing both hands in the handle recesses (arrows).

To close the tailgate, merely press it down gently. The closing process will then be carried out automatically.



To avoid injuries, be sure that the travel path of the luggage compartment lid/tailgate is clear when it is closed, as with all closing procedures. Operate the vehicle only when the luggage compartment lid/tailgate is completely closed. Otherwise, exhaust fumes could penetrate the interior of the vehicle. Should it be absolutely necessary to operate the vehicle with the luggage compartment lid/tailgate open:

- ▷ Close all windows. Shut the sliding/tilt sunroof.
- ▷ Increase the air supply for the air conditioner or automatic climate control to a high level. Refer to page [108](#) or [114](#). ◀

46 Luggage compartment

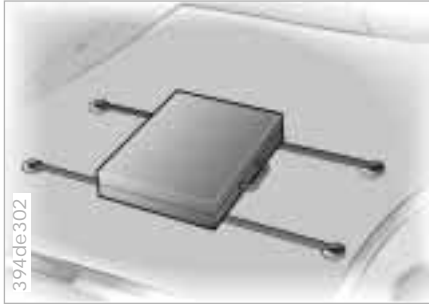

Luggage straps

Use the straps on the floor of the luggage compartment to secure smaller items of luggage.

Movement is reduced, when objects are placed on the straps.

The fittings at the corners of the luggage compartment provide you with a convenient means of attaching luggage nets* and flexible straps for securing suitcases and luggage.

Refer also to "Cargo loading" on page [136](#).



Hanger

On the left-hand side of the luggage compartment is a hanger for fastening shopping bags, packages or similar items.

Alarm system

The concept

The vehicle alarm system responds:

- ▷ When a door, the hood or the luggage compartment lid/tailgate is opened.
- ▷ To movement inside the vehicle (interior motion sensor).
- ▷ To variations in the vehicle tilt sensor such as occur during attempts to steal the wheels or tow the vehicle.
- ▷ To interruption of battery voltage.

The system responds to unauthorized vehicle entry and attempted theft by simultaneously activating the following:

- ▷ Sounding an acoustical alarm for 30 seconds.
- ▷ The hazard warning flashers are activated for approx. five minutes.
- ▷ The high beams flash on and off in the same rhythm.

To arm and disarm the alarm system

When the vehicle is locked or unlocked with the key or the remote control, the alarm system is also simultaneously armed or disarmed.

The interior motion sensor is activated approx. 30 seconds after you have finished locking the car.

The system indicates that it has been correctly armed by switching on the hazard flashers for a single cycle and by emitting an acoustical signal.



You can have different acknowledgment signals set to confirm arming and disarming. ◀

When the system is armed, you can still gain access to the luggage compartment lid/tailgate by pressing button 3 on the remote control (refer to page 41). When you close the luggage compartment lid/tailgate, it locks again.



Indicator lamp displays

- ▷ The indicator lamp below the interior rearview mirror flashes continuously: the system is armed.
- ▷ The indicator lamp flashes during arming: door(s), the hood or luggage compartment lid/tailgate are not completely closed. Even if you do not close the alerted area, the system begins to monitor the remaining areas, and the indicator lamp flashes continuously after 10 seconds. However, the interior motion sensor is not activated.
- ▷ If the indicator lamp goes out when the system is disarmed: no manipulation or attempted intrusions have been detected in the period since the system was armed.

48 Alarm system

- ▷ If the indicator lamp flashes for 10 seconds when the system is disarmed: an attempted entry has been detected in the period since the system was armed.

Following triggering of an alarm, the indicator lamp will flash continuously.

Avoiding unintentional alarms

The tilt alarm sensor and interior motion sensor may be switched off at the same time to prevent a false alarm from being triggered (in garages with elevator ramps, for instance), or when the vehicle is transported by trailer or train:

Lock the vehicle (arm the alarm system) twice in succession: press button 2 on the remote control transmitter twice (refer to page 40), or turn the key in the door lock to the right (lock) twice in succession (refer to page 38).

The indicator lamp lights up briefly and then flashes continuously. The tilt alarm sensor and the interior motion sensor are deactivated for as long as the system remains armed.



Interior motion sensor

The illustration depicts the transmitter and receiver of the interior motion sensor.

In order for the interior motion sensor to function properly, the windows and sliding/tilt sunroof must be completely closed.

Nevertheless, you should deactivate the interior motion sensor (refer to the previous column) if you intend to leave the windows or sliding/tilt sunroof open.

Electric power windows



Open and close windows

From ignition key position 1:

- ▷ Depress the rocker switch until you feel resistance:
The window continues moving for as long as you maintain pressure on the switch.
- ▷ Press the rocker switch beyond the resistance point:
The window moves automatically. Press the switch a second time to stop the window.

After the ignition has been switched off:

- ▷ You can still operate the windows as long as neither of the front doors has been opened. To open the window, press the switch beyond the resistance point.

 Remove the key from the ignition when you leave the vehicle, so that children cannot operate the power windows and possibly injure themselves. ◀

For the convenience mode via the door lock or the remote control, refer to pages [38](#) or [40](#).

Safety feature

A contact strip is integrated into the inner side of each of the upper window frame sections. If pressure is exerted against this contact strip while a window is being raised, the system will respond by stopping the window and then retracting it a small distance.

 Despite this safety feature, be extremely careful that the closing path of the window is not obstructed whenever it is closed. Otherwise, an object might not touch the contact strip in some situations (very thin objects, for instance).

You can override this safety feature by pressing the switch beyond the resistance point and holding it. Because the power windows are sealed at high pressure to prevent wind noise when closed, a powerful motor is required for efficient closing. When closing the windows, always be sure that they are not obstructed in any way. Unsupervised use of these systems can result in serious personal injury. Remove the ignition key to deactivate the electric power windows whenever you leave the car. Never leave the keys in the vehicle with unsupervised children. Never place anything that could obstruct the driver's vision on or next to the windows. ◀



Safety switch

With the safety switch, you can prevent the rear windows from being opened or closed via the switch in the rear passenger area (by children, for example).

 Press the safety switch whenever children are riding in the rear of the vehicle. Careless use of the power windows can lead to injury. ◀

 To prevent injuries, exercise care when closing the sliding/tilt sunroof and keep it in your field of vision until it is shut.

Before leaving the car, switch off the electric sunroof mechanism by taking out the ignition key. Do not leave children unattended in the vehicle with access to vehicle keys. Use of the key can result in starting of the engine and operation of vehicle systems such as power sunroof, etc. Unsupervised use of these systems can result in serious personal injury. ◀

You can avoid pressure or drafts in the passenger compartment when the sunroof is open or lifted by keeping the air vents in the instrument panel open and increasing the air supply as required. Refer to pages 108 or 114.

If the sunroof is completely open, air disturbances may be caused in the vehicle when you are driving at higher speeds. Close the roof as far as is necessary until this natural phenomenon ceases.

For the convenience mode via the door lock or the remote control, refer to page 38 or 40.

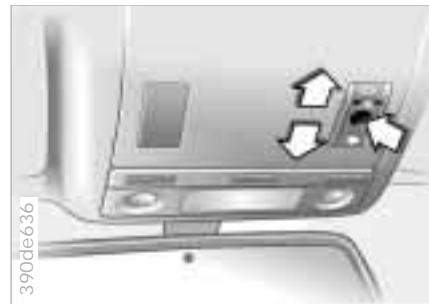

Lifting – opening – closing

From ignition key position 1, press the switch or slide it to the desired direction until you feel resistance.

When lifting, the headliner retracts several inches.

 If the sliding/tilt sunroof is up, then the headliner cannot be closed. ◀

After the ignition has been switched off, you can still operate the sliding/tilt sunroof as long as neither of the front doors has been opened.

Sliding/Tilt sunroof*

Automatic* opening and closing

Press the appropriate end of the control switch past the resistance point and then release it.

Other automatic operations are:

- ▷ With the sunroof open, press the switch briefly toward "Lift:" the sunroof automatically extends to its fully raised position.
- ▷ With the sunroof lifted, press the switch briefly toward "Open:" the sunroof automatically opens all the way.

Pressing the switch again briefly stops the motion.

Safety feature

If the sliding/tilt sunroof encounters resistance at a point roughly past the middle of its travel when it is closing, the closing cycle is interrupted and the sliding/tilt sunroof will open again slightly.



Despite this safety feature, be extremely careful that the closing path of the sunroof is not obstructed whenever it is closed. Otherwise, triggering the closing-force limitation may not be ensured in some situations (with very thin objects, for instance). You can override this safety feature by pressing the switch beyond the resistance point and holding it. ◀

Sliding/tilt sunroof with glass moonroof*

The options and control procedures are essentially the same as those previously described for the sliding/tilt sunroof. In order to open the raised roof, press the control switch towards "Open" until the roof has reached the desired position.

The headliner insert slides back somewhat when you raise the sunroof. When the sunroof is opened the headliner retracts with it. The headliner will then automatically remain in its retracted position, but can be repositioned as desired.



Power loss or malfunction

After interruptions in the electrical supply (when the battery is disconnected, for instance), the sunroof may only lift. To reinitialize the mechanism:

- 1 Raise the sliding/tilt sunroof all the way.
- 2 Press and hold the switch for approx. twenty seconds.

In the event of an electrical malfunction, you can also operate the sliding/tilt sunroof manually. Refer to page 198.

For maximum safety, please comply with the following instructions when adjusting a seat:

 Never try to adjust your seat while operating the vehicle. The seat could respond with unexpected movement, and the ensuing loss of vehicle control could lead to an accident. Wear the safety belt firmly against your body at all times. In the event of a frontal impact, a loose lap belt could slide over your hips, leading to abdominal injury. In addition, the safety belt's restraint effectiveness is reduced if the belt is worn loosely.

Never ride with the backrest reclined to an extreme horizontal angle (especially important for front passengers to remember). Keep the backrest relatively upright to minimize the risk of "sliding under" the safety belt and sustaining injury in an accident.

Do not slide the seats to the rear when the vehicle is at an extreme angle (on garage ramps or steep slopes, for instance), to prevent the shoulder strap's automatic height adjustment mechanism from disengaging. ◀

Correct sitting posture

To reduce strain on the spinal column, sit all the way back in the seat and rest your back fully against the backrest. The ideal sitting posture is achieved with your head extending from your spine in a straight line.

For long-distance driving, you may wish to increase the backrest tilt-angle slightly to reduce muscular tension. Please remember that you should always remain able to grasp the entire periphery of the steering wheel without straightening your arms.

Electric power seat(s*)



- 1 Tilt angle (only driver's side)
- 2 Forward/backward adjustment
- 3 Cushion height
- 4 Backrest angle
- 5 Head restraint height

Adjust the angle of the head restraints by tilting the head restraint, refer to page 53.

 Read and comply with the adjustment instructions in the previous column. Failure to do so can result in diminished personal safety. ◀

Lumbar support*

Refer to the BMW comfort seat on page 54.



- 1 Forward/backward adjustment**
Pull the lever and slide the seat to the desired position.
After releasing the lever, apply pressure to the cushion to ensure that the latch engages securely
- 2 Cushion height**
Pull the lever and apply weight to or remove weight from the seat as required



- 3 Backrest angle**
Pull the lever and apply weight to or remove weight from the backrest to reach the desired position
-  Comply with the adjustment instructions on page 52. Failure to do so could result in diminished personal safety. ◀



Head restraints

To adjust the angle of the front head restraints: adjust by tilting the head restraint.

To adjust the height of the front passenger and rear head restraints: adjust by pulling up or pressing down.

-  Head restraints reduce the risk of spinal injury in the event of an accident.
Adjust the head restraint so that its center is approximately level with your ears.
Leave the center rear head restraint in the fully-lowered position at all times, since pulling it out limits its function. ◀



This seat allows you to make additional adjustments for:

- 1 Lumbar support
- 2 Shoulder support

Lumbar support

You can adjust the backrest's contour for additional support in the curvature of your spine's lumbar region.

The upper hips and spinal column receive supplementary support to help you maintain a relaxed, upright posture.

- ▷ Press the front/rear of the switch: Increase/decrease curvature.
- ▷ Press the upper/lower end of the switch: Increase the upper/lower curvature.



Comply with the adjustment instructions on page 52. Failure to do so could result in diminished personal safety. ◀



Shoulder support

You can use the adjustable upper backrest for supplementary support in the shoulder region. This provides a relaxed sitting posture and helps relieve stress on the shoulder muscles.

Press the rocker switch: the support angle of the upper backrest section is adjusted.

To obtain an optimal seating posture, we recommend:

Driver and front passenger:

- 1 Adjust the upper backrest section to its extreme rear position.
- 2 Adjust to the optimal sitting posture as shown on page 52 under "Correct sitting posture."
- 3 Bring the upper backrest section forward until your shoulders enjoy firm support.

BMW comfort seat*

Front passenger's seat adjusted for relaxed traveling:

- 1 Adjust the upper backrest section to its extreme rear position.
- 2 Increase the seat cushion tilt.
- 3 Tilt the backrest more.
- 4 Bring the upper backrest section forward.

 Make corrections in the forward/backward adjustment of the seat to ensure that the safety belt still fits firmly against your body. If you do not do this, the protection provided by the safety belt may be reduced. ◀

BMW sports seat*

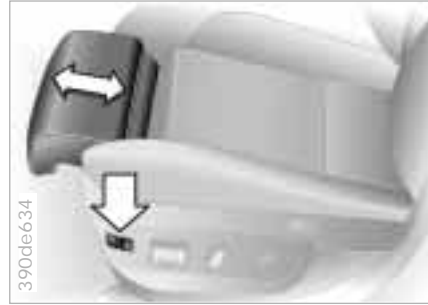

With this seat, you can also adjust the thigh support. To do that, press the switch.

BMW active seat*

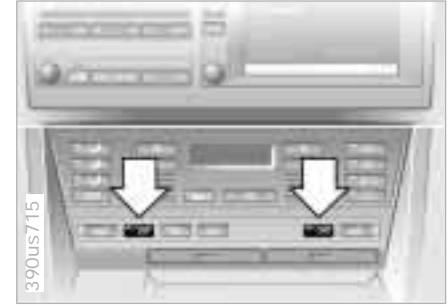

Active changes in the seat's surface help to avoid muscle cramps, pain in the spine's lumbar region and fatigue. To activate the seat, press the button (arrow).

For additional details concerning the BMW active seat, please refer to the chapter describing "Advanced technology" on page [210](#).



Automatic steering wheel adjustment

In order to make it easier to get into and out of the car, the steering wheel automatically moves into the top position and returns to the driving (memory) position.

This automatic feature is controlled by the position of the ignition key and by the driver's door.

The steering wheel can be moved in any of four directions. Adjust by moving the control lever in the desired direction.



Do not adjust the steering wheel while the vehicle is moving. There is a risk of accident from unexpected movement. ◀

To store the steering wheel setting, refer to "Seat, mirror and steering wheel memory" on page [58](#).



Exterior mirrors

1 Mirror switch for 4-way adjustment

2 Left/right selection switch

You can also adjust the mirrors manually by pressing against the outer edges of their lenses.

To store the mirror settings: refer to "Seat, mirror and steering wheel memory" on page [58](#).

Mirrors

⚠ The mirror on the passenger's side features a lens with a more convex surface than the mirror installed on the driver's side. When estimating the distance between yourself and other traffic, bear in mind that the objects reflected in the mirror are closer than they appear. This means that estimations of the distance to following traffic should not be regarded as precise. ◀

Electric heaters

Both mirrors are heated automatically with the ignition key in position 2.

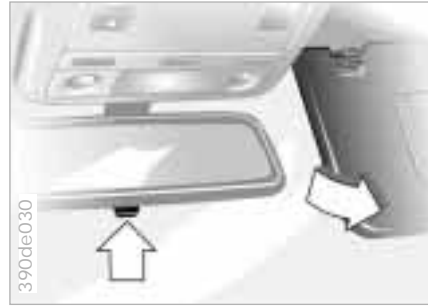

Interior rearview mirror

To reduce glare from vehicles behind you after dark, tilt the mirror by moving the small lever.

Lighted vanity mirror

Fold down the sun visor and slide the cover panel to the side as required.

The mirror lamps operate from ignition key position 1.

Sun visors

These can be folded down toward the windshield or swiveled out against the side windows.



Interior rearview mirror with automatic dimmer*

By responding to the effects of ambient light and the glare from following traffic, this mirror automatically dims through an infinitely-variable range.

The mirror automatically reverts to its clear, undimmed setting whenever you select "Reverse."

For proper functioning of the mirror, be sure that the two photocells are unobstructed and clean. One of the photocells (arrow) is positioned in the mirror's glass, while the other is slightly offset on the opposite side of the mirror.

For an explanation of the electro-chromic technology used in this mirror, refer to page [211](#).



You can store and call up three different seat, exterior mirror and steering wheel positions. The illustration shows the buttons on the driver's door for making these position adjustments.

The adjustment for the lumbar support is not stored in the memory.

To store

- 1 Ignition key at position 1 or 2.
- 2 Adjust the desired positions for the seat, door mirror and steering wheel.
- 3 Press the **MEMORY** button: the indicator lamp in the button comes on.
- 4 Press memory button 1, 2 or 3, as desired: the indicator lamp goes out.

To select a stored setting

Convenience function:

- 1 The driver's door remains open after unlocking or the ignition key is in position 1.
- 2 Briefly press memory button 1, 2 or 3, as desired.

Movement stops immediately when one of the seat adjustment or memory buttons is activated during the adjustment process.

Security function:

- 1 The driver's door is closed and the ignition key is either removed or in position 0 or 2.
- 2 Press and hold the desired memory button (1, 2 or 3) until the adjustment process is completed.

If you press the **MEMORY** button accidentally: press the button a second time; the indicator lamp goes out.



Do not call up a position from the memory while the vehicle is moving. There is a risk of accident from unexpected movement of the seat or steering wheel. ◀

Seat, mirror and steering wheel memory



Passenger side exterior mirror tilt function

(automatic curb monitor)

- 1 Move the mirror selector switch (arrow) to the "driver's mirror" position.
- 2 When the selector lever is placed in "Reverse," the passenger-side mirror tilts downward to help the driver monitor the area directly adjacent to the car during parking (curbs, etc.).

You can deactivate this automatic feature by setting the mirror selection switch to the "passenger side" position.



Your BMW center can adjust your vehicle's systems in such a manner that your personalized settings are automatically called up for the seat, mirror and steering wheel positions when you unlock the vehicle with the remote control of your personal key. ◀



If you make use of this setting mode, be sure that the footwell behind the driver's seat is unobstructed before unlocking the vehicle. If you fail to do so, any persons or objects behind the seat could be injured or damaged by a rearward movement of the seat. ◀



How the system functions

You have probably frequently wished that you could configure individual functions of your vehicle to reflect your own personal requirements. In engineering your vehicle, BMW has included several user-defined functions in the vehicle's design. Your authorized BMW center can make these settings for you. There are settings related to the vehicle ("Car Memory") and settings related to individuals ("Key Memory"). You can have two different basic positions configured for two different persons. The only requirement is that each person uses his or her own remote control key.

When your vehicle is unlocked with the remote control, the vehicle recognizes the individual user by means of a data exchange with the key, and makes adjustments accordingly.

In order for you to distinguish between different keys, colored decals are supplied together with the keys.

What the system can do

Your authorized BMW center can provide you with details on the capabilities of the Car Memory and Key Memory systems.



You will see this symbol throughout the Owner's Manual. It is to remind you at appropriate places of the settings that are available to you. ◀

An example of Key Memory is the automatic adjustment of the driver's power seat with stored settings for the individual person when the vehicle is unlocked.

Safety belts



Drive with your safety belt on

Fasten your safety belt at the beginning of every trip.

To fasten: make sure you hear the lock engage in the belt buckle.

To release: press the red button in the buckle. Hold the belt and guide it back into its reel.

The shoulder belt anchor automatically adjusts to continue providing an optimum fit when you move the seat forward or back.

The two rear safety belt buckles which are integrated in the rear seat are for passengers sitting on the left and right. The belt buckle with the word "CENTER" is intended exclusively for passengers sitting in the middle.

For care instructions, refer to page [174](#).

 For your safety, comply with the following instructions for wearing safety belts. If you do not, the safety belts may not be able to provide their maximum protection. All passengers in the vehicle should be aware of and comply with this information: Never allow more than one person to wear a single safety belt. Never allow infants or small children to ride in a passenger's lap.

Avoid twisting the belt while routing it firmly across the hips and shoulder, wear it as snugly against your body as possible. Do not allow the belt to rest against hard or fragile objects. Do not route the belt across your neck, or run it across sharp edges. Be sure that the belt does not become caught or jammed.

Avoid wearing bulky clothing and pull on the belt periodically to re-tension it over your shoulders. In the event of a frontal impact, a loose lap belt could slide over your hips, leading to abdominal injury. In addition, the safety belt's restraint effectiveness is reduced if the belt is worn loosely.

Expectant mothers should always wear their safety belts, taking care to position the lap belt against the lower hips, where it will not exert pressure against the abdominal area. ◀

 sedan with through-loading system*: please comply with the instructions for the center safety belt on page [128](#).

sport wagon: if the center safety belt cannot be pulled out, the larger rear backrest section is not engaged. Refer to page [132](#). ◀

 If the safety belt system has been subjected to the stresses involved in an accident or otherwise damaged: have the entire safety belt mechanism replaced by your BMW center, including the safety belt tensioner. In addition, have your BMW center inspect the safety belt anchors. If a child restraint system was in the vehicle during an accident, consult the manufacturer's instructions regarding replacement. ◀

Child restraint systems*

 Never install a rear-facing child restraint device on the front passenger seat. Otherwise, injuries could occur when the airbag is triggered in the event of an accident.

Children should always ride in the rear and the restraint systems should be secured with the outer belts.

The centre seat belt should only be used when it is necessary to secure three child restraint systems.

Do not attempt to modify child restraint systems. If you do this, the protection provided by these systems could be impaired. ◀

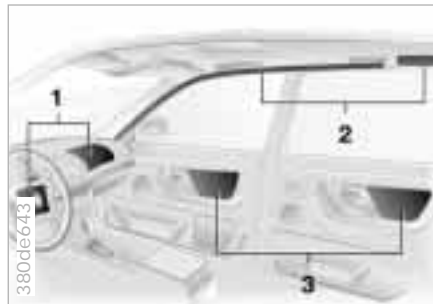

- 1 Front airbags on the driver and passenger sides
- 2 Side Impact Head Protection System on the driver and passenger sides (front and rear*)
- 3 Side airbags on the driver and passenger sides (front and rear*)

Protective effect

The front airbags protect the driver and passenger in the event of a head-on collision where the protection provided by the safety belt alone would not be adequate. The Head Protection System and side airbags help provide protection in the event of a collision from the side. Each of the side airbags is designed to help support the seat occupant's upper body.

 The side airbags in the rear passenger area* of your vehicle may already have been deactivated, either at the time of manufacture or by a BMW center. You may have them activated if you desire to do so. Please contact your authorized BMW center for additional information. ◀



The illustration depicts schematically the primary directions of vehicle impact which initiate an airbag deployment.

 The airbags will not be triggered in the event of a minor accident, a vehicle roll-over, or collisions from the rear. ◀

Operational status



The indicator lamp displays the operational status of the airbag system from ignition key position 1.

System operational:

- ▷ The indicator lamp comes on briefly then goes out.

System malfunction:

- ▷ The indicator lamp fails to come on.
- ▷ The indicator lamp comes on briefly before going out and then lighting up again.

A system malfunction could prevent the system from responding to an impact occurring within its normal response range.

Have the system checked by your BMW center immediately.

Sitting correctly with airbags



For your safety, comply with the following instructions for the airbags. If you do not, the airbags may not be able to provide their maximum protection. All passengers in the vehicle should be aware of and comply with this information:

Even though there is an airbag, wear a safety belt every time you get in the vehicle, because airbags enhance safety by providing added protection. Make sure you are seated comfortably in your seat, in such a way that you always maintain control, and are not too close to the steering wheel.

Always hold the steering wheel by the rim to keep any chance of injury to hands or arms to an absolute minimum, should the airbag be deployed. No one and nothing is to come between the airbag and the seat occupant. Do not use the cover panel above the front passenger-side airbag as a storage area.

Do not apply adhesive materials to the cover panels of the airbags, cover them or modify them in any other way.

Do not install a rear-facing child restraint system in the front passenger seat of this car.

Children under 13 years of age and children less than 5 ft (150 cm) tall should ride only in the rear seat.

Infants or small children should never be held on the lap of a passenger.

If your car is equipped with side airbags in the rear passenger area, be sure that child restraints are mounted correctly and provided with the greatest-possible distance between the airbags in the side trim panels. Do not allow children to lean out of the child's seat in the direction of the side trim panels. If they do so, serious injuries can occur if the airbag is triggered. ◀



At all times, occupants should sit upright and be properly restrained (infants and small children in appropriate child restraint systems; larger children and adults using the safety belts). Never let an occupant's head rest near or on a side airbag because the inflating airbag could cause a serious or fatal injury. Please note that the word "Airbag" imprinted on the door trim panel indicates the airbag's location.

Accident research shows that the safest place for children in an automobile is in the rear seat. However, a child sitting in the rear seat and not properly restrained may place his or her head on or near the side airbag, if so equipped. For example, a child – even though belted – may fall asleep with his or her head against the side airbag. It may be difficult for a driver to ensure that children in the rear seat will remain properly positioned at all times and not place their heads on or near the side airbag.

Therefore, we recommend that the rear seat side airbags, if provided, be deactivated if you plan to transport children in the rear seat.

The rear seat side airbags may already have been deactivated, either at the time of manufacture or by a BMW center. Labels in the rear door opening should indicate the status of your rear seat side airbags. If you are uncertain of their status, or wish to have the airbags activated or deactivated, please contact your BMW center. ◀

Even when all these guidelines are followed, there is still a small residual risk of injuries to the face, hands and arms occurring from airbag deployment in isolated instances. The ignition and inflation noise may provoke a mild temporary hearing loss in extremely sensitive individuals.

Airbag warning information is also provided on the sun visors.

For additional information concerning the airbag system, refer to pages [176](#) and [206](#).



This is the right way for a child to sit in a child restraint when rear side airbags (arrow) are provided.



This is the right way for a larger child to sit wearing the safety belt when rear side airbags (arrow) are provided.

Transporting children safely

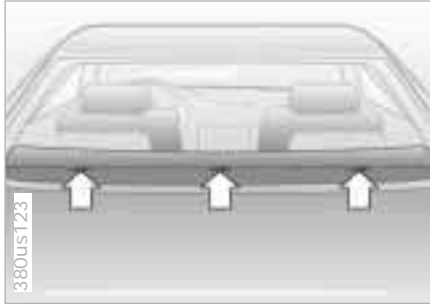

Commercially-available child restraint systems are designed to be secured with a lap belt or with the lap belt portion of a combination lap/shoulder belt. Improperly or inadequately installed restraint systems can increase the risk of injury to children. Always read and follow the instructions that come with the system.

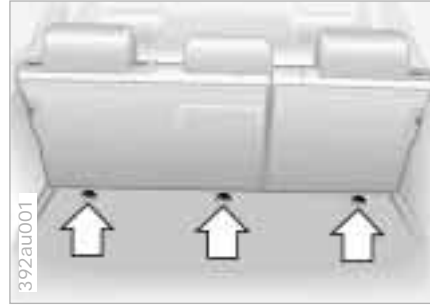

If you use a child restraint system with a tether strap, three additional tether anchorage points (refer to the arrows – the illustration shows the sport wagon) have been provided. Depending on the location selected for seating in the rear passenger area, attach the tether strap to the corresponding anchorage point to secure the child restraint system. Remove the cover first on the middle location.

If the respective seating position is fitted with a headrest lift the headrest and pass the tether strap between the headrest and the seat back.

Adjust the tether strap according to the child restraint manufacturer's instructions.



Before installing any child restraint device or child seat, please read the following:

Never install a rear-facing child restraint system in the front passenger seat of this car.

Your car is equipped with an airbag supplemental restraint system for the front passenger. Because the backrest on any rear-facing child restraint system (of the kind designed for infants under 1 year and 20 lbs./9 kg) would be within the airbag's deployment range, you should never mount such a device in the front passenger seat, since the impact of the airbag against the child restraint's backrest could lead to serious or fatal injuries. If it is necessary for a child (not an infant) to ride in the front seat, certain precautions should be taken. First, move the passenger seat as far away from the dashboard as possible. This important precaution is intended to maximize the distance between the airbag and the child.

Transporting children safely

Older children should be tightly secured with a safety belt. Younger children should be secured in an appropriate forward-facing child restraint system that has first been properly secured with a safety belt. Never install a rear-facing child restraint system in the front passenger seat.

We strongly urge you to carefully read and comply with the instructions for installation and use provided by the child restraint's manufacturer whenever you use such a device.

Be sure that all occupants (of all ages) remain properly and securely restrained at all times. ◀

All rear seating positions in your vehicle meet the recommendations of SAE J1819, an industry-recommended practice for securing child restraint systems in motor vehicles.



Child restraint installation

All of the rear belt retractors and the front passenger's safety belt can be locked for mounting and securing child restraint systems. A label with the appropriate instructions for this is located in the immediate vicinity of the buckle latch of each safety belt.

Lock the safety belt

Pull the entire length of the belt from the inertia reel mechanism. Allow the reel to retract the belt somewhat and engage the buckle, then tighten the belt against the child restraint system. The retraction mechanism is now locked.

Unlock the safety belt

Release the safety belt, remove the child's seat and retract the safety belt to its end position on the belt retractor.



Child-safety locks

Insert the key to the slot of a rear door lock and turn it outward:

The door can now be opened from the outside only.

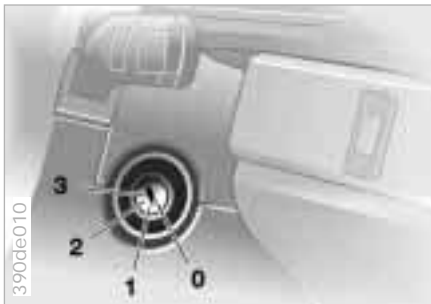

0 Steering lock engaged

This is the only position in which the ignition key can be inserted and removed.

After removing the key, turn the steering wheel slightly to the left or right until you hear the lock engage.

Once the ignition has been switched off (ignition key in position 0 or pulled out), the radio functions are still available for approx. 20 minutes. Turn the radio back on to use it.



Vehicles with automatic transmission:

Do not move the selector lever from position "P" until the engine is running (ignition key position 2).

Your vehicle is equipped with an interlock. Therefore, the ignition key cannot be turned to position 0 and removed until the selector lever is in position "P" (Interlock). ◀

1 Steering lock disengaged

You will find that it is often easier to turn the ignition key from position 0 to position 1 when you move the steering wheel slightly to help disengage the lock.

2 Ignition on

All electrical equipment and accessories are available for use.

3 Starting the engine

Starting the engine

Before starting

- ▷ Engage the parking brake.
- ▷ Put the manual-shift gear lever in idle or in P for an automatic transmission.
- ▷ Step on the clutch pedal.



Do not allow the engine to run in enclosed spaces. The exhaust gases contain carbon monoxide, an odorless and colorless, but highly toxic gas. Breathing the exhaust gases poses an extreme health risk, and can lead to unconsciousness and death.

Never leave the vehicle unattended with the engine running. An unattended vehicle with a running engine represents a potential safety hazard. ◀

Starting the engine

Starting the engine

- ▷ Start the engine. Do not press the accelerator pedal.



Do not actuate the starter for too short a time. Do not turn it for more than approx. 20 seconds. Release the ignition key immediately as soon as the engine starts.

Do not allow the engine to warm up by leaving it running while the vehicle remains stationary. Instead, begin driving immediately at a moderate engine speed.

BMW 540i with automatic transmission: Your BMW is equipped with the convenience starting feature. Simply turn the key to position 3 (starter) and then release it immediately.

The starter continues to operate automatically.

The automatic starting mode will not operate if the battery voltage is low.

Should this condition arise, it remains possible to jump-start the engine (refer to page 200). ◀

Should the engine fail to start on the first attempt (if it is very hot or cold, for instance):

- ▷ Press the accelerator pedal halfway down while engaging the starter.

Cold starts at extremely low temperatures, from approx. +5 °F (-15 °C) and at elevations above 3,300 ft (1,000 meters):

- ▷ Be sure to let the starter remain engaged somewhat longer the first time (approx. 10 seconds).
- ▷ Press the accelerator pedal halfway down while engaging the starter.

Engine idle speed is controlled by the engine computer system. Increased speeds at start-up are normal and should decrease as the engine warms up. If engine speed does not decrease, service is required.

To prevent the battery from discharging, always deactivate electrical devices which are not in use. Switch the ignition off when the vehicle is not being driven.

Switching off the engine 69

Turn the ignition key to position 1 or 0.



Never remove the ignition key while the vehicle is rolling. The steering locks, making it impossible to steer the vehicle.

Always remove the ignition key and engage the steering lock before leaving the vehicle.

Vehicles with manual transmission: Always engage the parking brake when parking on slopes and inclined surfaces, since not even placing the lever in 1st gear or reverse may not provide adequate resistance to rolling. Vehicles with automatic transmission: Place the selector lever in "Park." ◀

Vehicles with automatic transmission*: The vehicle must be stationary and the selector lever in "Park" before you can remove the ignition key.



The parking brake is primarily designed to prevent the vehicle from rolling while parked. It operates against the rear wheels.

To engage

The lever engages automatically and the "PARK BRAKE" or "BRAKE" (in Canada "P") indicator lamp comes on in the instrument cluster in ignition key position 2. Refer to pages [22](#) and [23](#).

To release

Pull up slightly on the lever, press the button and lower the lever.

 If, in exceptional circumstances, it should be necessary to engage the parking brake while the vehicle is in motion, do not pull it with excessive pressure. Keep your thumb pressed against the release button while carefully pulling up the lever to apply moderate pressure. Excessive pressure can lead to over-braking and loss of traction (fishtailing) at the rear.

The brake lamps do not come on when the parking brake is applied.

Vehicles with manual transmission:

Always engage the parking brake when parking on slopes and inclined surfaces, since not even placing the lever in 1st gear or reverse may not provide adequate resistance to rolling.

Vehicles with automatic transmission: Place the selector lever in "Park." ◀

To avoid corrosion, apply the parking brake lightly from time to time when coasting to a standstill (at a traffic signal, for instance), provided that it is safe to do so.



BMW 525i, BMW 530i

Every time you shift gears, always depress the clutch pedal all the way down, pushing the manual-shift gear lever into the respective end position.

Depress the clutch even when starting the engine, otherwise, a lock will prevent the engine from being started.

The shift lever's neutral gate (dot in the illustration) is located between 3rd and 4th gears.

When shifting from each gear into "Neutral," the shift lever returns automatically to this neutral position because of its spring loading.

Manual transmission



BMW 540i

Every time you shift gears, always depress the clutch pedal all the way down, pushing the manual-shift gear lever into the respective end position.

Depress the clutch even when starting the engine, otherwise, a lock will prevent the engine from being started.

The shift lever's neutral gate (dot in the illustration) is located between 3rd and 4th gears.

When shifting from each gear into "Neutral," the shift lever returns automatically to this neutral position because of its spring loading.

 When shifting gears in the 5th/6th-gear plane, be sure to press the gear lever to the right in order to prevent inadvertent selection of a gear in the 3rd/4th-gear plane. ◀

Reverse

Select "Reverse" only when the vehicle is stationary. Press the shift lever to the left to overcome the resistance.

As you do this, the backup lamps will turn on automatically when the ignition key is in position 2.

 Do not hold the vehicle in place on slopes by slipping or "riding" the clutch. Use the parking brake instead. Riding the clutch causes increased clutch wear. ◀



The automatic transmission of your BMW is equipped with Adaptive Transmission Control (ATC), a system which reacts with precision to your individual driving style and the driving conditions. To achieve this, different driving programs are automatically engaged.

For details concerning ATC, please refer to the chapter describing "Advanced technology" on page [206](#).

Selector lever positions

P R N D 4 3 2

The transmission range display varies according to model (refer to illustrations).

Starting engine

The selector lever must be in "Park" or "Neutral" before it is possible to start the engine.

Range selection

A detent prevents inadvertent shifts into some selector lever positions. To release the shift-lock mechanism, press the button on the front of the selector handle (arrow).



While the vehicle is stationary and before shifting out of "Park" or "Neutral," depress the footbrake in order to disengage the selector lever's lock mechanism (Shiftlock). Hold the footbrake down until starting off. Otherwise the vehicle will "creep" when a drive position is engaged. ◀

Automatic transmission*



Before leaving the vehicle when the engine is running, shift the selector lever to the "Park" or "Neutral" position and apply the parking brake. The vehicle could move if this is not done.

Never leave the vehicle unattended with the engine running. An unattended vehicle with a running engine represents a potential safety hazard.

If you should accidentally select "Neutral" while traveling at high speed, remove your foot from the accelerator pedal immediately. Allow the engine speed to drop to idle before selecting the desired drive position. Damage could otherwise occur due to excessive engine speed. ◀

P Park

Select "Park" only when the vehicle is stationary. The transmission locks to prevent the rear wheels from turning.

R Reverse

Select "Reverse" only when the vehicle is stationary.

N Neutral

Select "Neutral" only if your journey is interrupted for a long period.

D Drive (automatic shift program)

This position is designed for driving under all normal operating conditions. All forward gears are available.

4 – Sport Program

This position is recommended if you wish to select a performance-oriented driving style.

3 and 2 – shift limiter

Select this range when you wish to limit gear changes (on steep uphill or downhill slopes, for instance). The transmission shifts up only as far as the selected gear.

"Kickdown"

In the "Kickdown" mode, you achieve maximum performance. To activate this mode, depress the accelerator pedal beyond the full-throttle position, at which a resistance point must be overcome.

Electronic transmission control module



If the indicator lamp comes on or if the message "TRANS. FAILSAFE PROG" appears in the Check Control*, there is a malfunction in the transmission system.

Bring the vehicle to a stop, select the "Park" position, apply the parking brake and shut the engine off (ignition key position 0). Restart the engine after a few seconds. If the indicator lamp goes out again after a few seconds, the normal transmission functions have been restored. You may continue to drive as usual.

If the indicator lamp does not go out, you can place the selector lever in all positions. However, the vehicle will now only drive forward with limited gear selection.

Under these circumstances, avoid extreme engine loads and consult the nearest BMW center.



Do not work in the engine compartment when a drive gear (forward or reverse) is engaged. If you do this, the vehicle could move. ◀

For jump-starting, towing and tow-starting, refer to pages [200](#) and [201](#).

You can drive just as you do with a normal automatic transmission, including Adaptive Transmission Control (ATC), but in addition, you can also shift manually.

For individual gear selection, move the selector lever from the "D" position to the left and into the M/S range. This selects the Sport Program of the automatic transmission. As soon as you move the selector lever in the "+" or "-" direction, Steptronic changes the gear. If you wish to utilize the automatic driving position once again, move the selector lever to the right and into position "D."

For details concerning ATC, please refer to the chapter describing "Advanced technology" on page [207](#).



Selector lever positions

P R N D M/S

Starting engine

The engine can only be started in selector lever positions P ("Park") or N ("Neutral").



Range selection

A detent prevents inadvertent shifts to the "Reverse" or "Park" selector lever positions. To disengage the detent, press the button on the front of the shift knob (arrow).



While the vehicle is stationary and before shifting out of "Park" or "Neutral," depress the footbrake in order to disengage the selector lever's lock mechanism (Shiftlock). Hold the footbrake down until starting off. Otherwise the vehicle will "creep" when a drive position is engaged. ◀



Before leaving the vehicle when the engine is running, shift the selector lever to the "Park" or "Neutral" position and apply the parking brake. The vehicle could move if this is not done. Do not leave the car unattended with the engine running. An unattended vehicle with a running engine represents a potential safety hazard. If you should inadvertently select "Neutral" while traveling at high speed, remove your foot from the accelerator pedal immediately. Allow the engine speed to drop to idle before selecting the desired drive position. Damage could otherwise occur due to excessive engine speed. ◀

P Park

Select "Park" only when the vehicle is stationary. The transmission locks to prevent the rear wheels from turning.

R Reverse

Select "Reverse" only when the vehicle is stationary.

N Neutral

Select "Neutral" only if your journey is interrupted for a long period.

D Drive (automatic shift program)

This position is designed for driving under all normal operating conditions. All forward gears are available.

"Kickdown"

In the "Kickdown" mode, you achieve maximum performance. To activate this mode, depress the accelerator pedal beyond the full-throttle position, at which a resistance point must be overcome.

**M/S Manual mode and Sport Program**

When you change from "D" to "M/S," the Sport Program is activated. This is indicated by "D S" in the gear selection display. The Sport Program is designed for performance-oriented driving.

With the first brief touch, the automatic transmission shifts from the Sport Program to the manual mode. Whenever you move the selector lever forward in the "+" direction, the transmission shifts up, and when you move it backward in the "-" direction, the transmission will shift down. M1...M5 will be displayed in the gear indicator.

Upshifts or downshifts will be carried out by the ATC only at appropriate engine speeds and road speeds. For instance, if engine speed is too high, a downshift will not be executed. The gear selected will appear briefly in the instrument cluster followed by the current gear.

 If you are driving in the manual mode and wish to accelerate rapidly from low road speeds (when passing, for instance), you must shift down manually or with the "Kickdown" function. ◀

You can only change from "M/S" to selector lever positions "P," "R," and "N" via the "D" position.

In the following situations, the Steptronic "thinks" for you in the manual mode:

- ▷ In order to prevent engine over-speeding, the transmission shifts automatically to the next higher gear shortly before the RPM cutoff point
- ▷ At low speeds, the transmission shifts down automatically - you do not have to act.
- ▷ In the "Kickdown" mode, the transmission shifts down to the lowest gear which is possible, depending on the engine speed.

- ▷ According to the situation, for instance in wintry conditions, the vehicle can be started in 2nd or 3rd gear.

Electronic transmission control module



If the indicator lamp comes on or the message "TRANS.FAIL-SAFE PROG" appears in the Check Control*, there is a fault in the transmission system.

Bring the vehicle to a stop. Move the transmission selector lever to "P." Set the parking brake and turn the engine off (ignition key to position 0).

Wait a few seconds, then start the engine.

If the indicator lamp goes out after a few seconds, normal transmission performance has been restored. You may continue to drive as usual. If the indicator lamp does not go out, you can place the selector lever in all positions. However, the vehicle will now only drive forward with limited gear selection.

If this happens, avoid extreme engine loads and consult the nearest BMW center.



Do not work in the engine compartment when a drive gear (forward or reverse) is engaged. If you do this, the vehicle could move. ◀

For jump-starting, towing and tow-starting, refer to pages [200](#) and [201](#).

Indicator/Headlamp flasher Wiper/Washer system



- 1 High beam (blue indicator lamp)
- 2 Headlamp flasher (blue indicator lamp)
- 3 Turn signal indicator (green indicator lamp accompanied by periodic clicking sound from the relay)

If the indicator lamp and the clicking from the relay are both faster than normal, one of the turn signal indicators has failed.

To signal briefly

Press the lever up to but not beyond the detent. It then returns to the center position when released.



- 0 Wipers retracted
- 1 Intermittent mode or rain sensor*
- 2 Normal wiper speed
- 3 Fast wiper speed
- 4 Brief wipe
- 5 Cleaning windshield
- 6 Intensive cleaning*
- 7 Rotary dial for control of the wiper interval or the sensitivity of the rain sensor*

1 Intermittent mode or rain sensor*

Intermittent mode:

You can set the wipe interval to four stages with rotary dial 7.

In addition, the wipe interval is varied automatically depending on road speed.

Rain sensor:

When the rain sensor is activated, the windshield wiper is controlled automatically, depending on the degree of wetness of the windshield (in both snow and rain). You do not have to be concerned with switching the windshield wiper on or off or adjusting the wipe interval between intermittent and full wipe. Instead, you can concentrate fully on the traffic conditions. This is especially important under adverse weather conditions.

The rain sensor is positioned on the windshield, directly ahead of the interior rearview mirror.

To activate the rain sensor:

From ignition key position 1 and up, move the lever to position 1. The wipers travel once across the windshield, regardless of the weather.

Wiper/Washer system

You can leave the lever permanently in position 1. It is then only necessary to activate the rain sensor from ignition key position 1 and up. To do this

- ▷ turn rotary dial 7 briefly or
- ▷ use either the cleaning windshield 5 or the intensive cleaning 6.

To modify the sensitivity of the rain sensor:

Turn rotary dial 7.

To deactivate the rain sensor:
Move lever to position 0.

 Turn the rain sensor off in automatic car washes. Failure to do so could result in damage caused by undesired wiper activation. ◀

2 Normal wiper speed

The wipers automatically revert to intermittent operation when the vehicle is stationary (not on vehicles with rain sensor*).

3 Fast wiper speed

The wipers automatically revert to normal speed when the vehicle is stationary (not on vehicles with rain sensor*).

5 Cleaning windshield

The system sprays washer fluid against the windshield and activates the wipers for a brief period.

If you only pull the lever briefly, the system sprays washer fluid onto the windshield without activating the wipers.

6 Intensive cleaning*

As in setting 5. In addition, an intensive-action washer fluid is first sprayed on the windshield.

For changing the wiper blades, refer to page [182](#).

Cleaning headlamps*

If they are on, the headlamps will also be cleaned every fifth time you activate cleaning windshield (5) or intensive cleaning (6).



Do not use the washers if there is any danger that the fluid will freeze on the windshield, otherwise vision could be obscured. For this reason, use an antifreeze agent. Refer to page [164](#).

Do not use the washers when the reservoir is empty, since this could cause damage to the washer pump.

Windshield washer jets

The windshield washer jets are warmed automatically when the ignition key is in position 2.

Wiper/Washer system



Programming is cleared:

- ▷ Approx. 10 seconds after the lever is placed in position 0 or
- ▷ after the engine is switched off.

When the rear window is opened, the rear window wiper is switched off. It must be switched on again after the window has been closed.

For changing the wiper blade, refer to page [182](#).

Rear window wiper – sport wagon

- 0 Rest position of the rear window wiper
- 1 Rear window wiper in intermittent operation. When reverse gear is engaged, continuous operation is switched on automatically
- 2 Cleaning rear window

You can also program the interval:

- ▷ Switch briefly from position 0 to position 1.
- ▷ The time until reactivation (from position 0 to 1) is the programmed interval (max. 30 seconds).

Rear window defroster



To activate

Press the button: as long as the indicator lamp remains on, the rear window defroster continues at high-output (rapid thaw).

After the indicator lamp goes out, the defroster continues operating at reduced power for a limited period before deactivating automatically.

Vehicles with automatic climate control: For the selection button refer to page [116](#).

To deactivate

If the indicator lamp is on, press the button.

Cruise control



You can store and automatically maintain any desired vehicle speed above approx. 20 mph (30 km/h).

 Do not use cruise control on twisting roads, when high traffic density prevents driving at a constant speed, or when the road surface is slick (snow, rain, ice) or loose (rocks or gravel, sand). ◀

To activate the system

In ignition key position 1 or 2:
Press button 1; the indicator lamp in the instrument cluster comes on.
You can now use the cruise control.

To store and maintain speed or to accelerate

Press button 2 briefly:
The system stores and maintains the current vehicle speed. Every time you tap the button, the speed increases by 0.6 mph (1 km/h).

Press and hold button 2:
The vehicle accelerates without pressure on the accelerator pedal. When you release the button, the system stores and maintains the current speed.

 If, on a downhill gradient, the engine braking effect is not sufficient, the controlled speed can be exceeded. Speed can drop on uphill grades if the engine output is insufficient. ◀

To decelerate

Press button 3 briefly:
When cruise control is active, every tap of the button reduces the speed by approx. 0.6 mph (1 km/h).

Press and hold button 3:
With the cruise control active, the system automatically reduces the throttle opening to slow the vehicle. When you release the button, the system registers and maintains the current speed.

To interrupt the cruise control

When the system is activated, press button 1. The indicator lamp stays on. You can use the cruise control again as desired.

In addition, the system is also automatically deactivated in response to the following conditions:

- ▷ When you apply pressure to the brake pedal.
- ▷ When you apply pressure to the clutch pedal, and when you move the automatic transmission selector lever from "Drive" to "Neutral".
- ▷ If you exceed or fall below the programmed speed for an extended period (by depressing the accelerator, for example).

To resume the stored setting

Press button 4:

The vehicle accelerates to and maintains the last speed stored. When you turn the ignition key to position 0, the stored speed is deleted from the system's memory and the system is deactivated.

To deactivate the system

When the cruise control has been interrupted, press button 1 again. The indicator lamp goes off and the stored speed is canceled.



1 Odometer

You can activate the displays shown in the illustration with the ignition key in position 0 by pressing the button in the instrument cluster (arrow).

The range of available displays varies according to your individual vehicle's equipment.

2 Trip odometer

To reset the trip odometer to zero, press the button (arrow) with the ignition key in position 1 or 2.

3 Outside temperature display

The outside temperature appears in the display panel as soon as you turn the ignition key to position 1.

You can change the units of measure (°F/°C) by

- 1 pressing and holding down the button (arrow) with the ignition key in position 1
- 2 turning the ignition key to 0.

Refer also to page [89](#).

Ice warning

If the outside temperature drops to approx. +37.5 °F (+3 °C), a warning signal sounds and the display flashes briefly.

The warning is repeated whenever the temperature climbs to at least +43 °F (+6 °C) and then drops again to +37.5 °F (+3 °C).

 The ice warning does not alter the fact that surface ice can form at temperatures above +37.5 °F (+3 °C), on bridges or shaded road surfaces, for instance. ◀



Never allow the engine to operate with the needle in the red overspeed zone of the gauge.

To protect the engine, the engine-management system automatically interrupts the fuel supply in this range; the resulting effect resembles that associated with a sudden loss of power.



Indicates current fuel consumption in mpg (in liters per 100 km on Canadian vehicles). This instrument shows whether your current driving style is conducive to fuel economy with minimum exhaust emissions.

When the vehicle is stationary, the display goes to "Maximum" (zero on Canadian models).



When you switch on the ignition, the indicator lamp comes on briefly to confirm that the system is operational.

If the indicator lamp stays on, there are approx.

- ▷ 2.0 gal (8 liters) – BMW 525i, BMW 530i
 - ▷ 2.5 gal (10 liters) – BMW 540i
- remaining in the tank.

Tank capacity: refer to page [223](#).

Certain operating conditions (such as those encountered in mountainous areas) may cause the needle to fluctuate slightly.



Please refuel early, since driving to the last drop of fuel can result in damage to the engine and/or catalytic converter. ◀

Coolant temperature gauge



Between the blue and red zones

Normal operating range. It is not unusual for the needle to rise as far as the edge of the red zone in response to high outside temperatures or severe operating conditions.

Checking coolant level: refer to page [167](#).

Blue

The engine is still cold. Drive at moderate engine and vehicle speeds.

Red

When you switch on the ignition, the warning lamp* comes on briefly to confirm that the system is operational.

If the the warning lamp lights up while driving, or the message "Coolant temperature" shows up in the Check Control*, then the engine has overheated. Switch the engine off immediately and allow it to cool down.

Service Interval Display

85



The precise layout varies according to the individual model version.

Green lamps

The number of illuminated lamps decreases as the time for your next maintenance visit approaches.

Yellow lamp

This field appears together with OILSERVICE or INSPECTION.

Maintenance is due. Please contact your BMW center for an appointment.

Red lamp

The maintenance deadline has been passed.

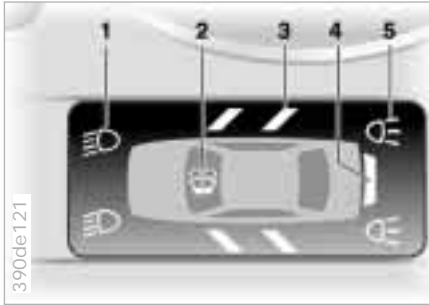

Graphic display*

The following alerts or status messages are displayed symbolically from ignition key position 2 and up until the defects are corrected:

- 1 Check headlamps
- 2 Add washer fluid
(goes out after approx. 1 minute)
- 3 Door open
- 4 Luggage compartment lid/tailgate open
- 5 Check brake and tail lamps.
A defective center tail lamp is indicated by the upper symbol

When you open the door after stopping, a warning signal sounds without a visual indicator for:

- ▷ LIGHTS ON and
- ▷ KEY IN IGNITION LOCK.



Alphanumeric display*

Text messages are used to alert the driver to system malfunctions when the ignition key is turned to position 2. The alert is accompanied by a gong.

- 1 Status report symbol
- 2 Display
- 3 CHECK button

Messages concerning system faults are differentiated based on two priorities:

Priority 1

These defects are immediately indicated by a gong and a flashing warning symbol 1. Simultaneous defects will be displayed consecutively. These status reports remain in the display until the defects are corrected. It is not possible to delete them by pressing the CHECK button 3:

- ▷ RELEASE PARKINGBRAKE
- ▷ COOLANT TEMPERATURE
The coolant is overheated. Stop the vehicle immediately and switch off the engine. Refer to pages 85 and 167.
- ▷ STOIENGINE OILPRESS
The oil pressure is too low. Stop the vehicle immediately and switch off the engine. Refer to page 22.
- ▷ CHECK BRAKE FLUID
Indicates that brake fluid is down to roughly minimum level. Top up the brake fluid at the next opportunity. Refer to page 168. Have the source of the brake fluid loss diagnosed and corrected by your BMW center.
- ▷ TIRE DEFECT*
Reduce vehicle speed immediately and stop the vehicle. Avoid hard brake applications. Do not oversteer. Refer to page 104.
- ▷ SELFLEVEL SUSP.INACT
Please consult the nearest authorized BMW center. Refer to page 148.
- ▷ SPEED LIMIT*
Display if the programmed speed limit has been exceeded.

Priority 2

These displays appear for 20 seconds when the ignition key is turned to position 2. The warning symbols remain after the message disappears. You can display the messages again by pressing the CHECK button 3:

- ▷ TRUNKLID OPEN
Message appears only when the vehicle is initially set in motion.
- ▷ DOOR OPEN
This message appears after a minimal defined road speed has been exceeded.
- ▷ FASTEN SEAT BELTS*
In addition to this message, a warning lamp with the safety belt icon appears and an acoustical signal sounds.
- ▷ WASHER FLUID LOW
Too low; top up fluid at the next opportunity. Refer to page 164.
- ▷ CHECK ENGINE OIL LEV
The oil level is at the absolute minimum, and therefore engine oil should be added as soon as possible. Refer to page 165. Until then, do not drive more than approx. 30 miles (50 km)

- ▷ CHECK FILLER CAP
Check that the filler cap is closed correctly, refer to page 28. A loose or missing cap will activate the message "CHECK FILLER CAP" in the Check Control* or the Service Engine Soon lamp.
- ▷ OUTSIDE TEMP. +20 °F (-5 °C)
This display is only an example. The current temperature is displayed at outside temperatures of +37.5 °F (+3 °C) and below. Refer also to page 83.
- ▷ SET TIRE PRESSURE*
The RDC has imported the current inflation pressure in the tires as the target values which the system will monitor. Refer to page 103.
- ▷ CHECK TIRE PRESSURE*
Check and correct the tire inflation pressure to specifications at the earliest opportunity (next stop for fuel). Refer to page 104.
- ▷ TIRECONTROL INACTIVE*
A temporary interference of the RDC or a system fault. Refer to page 104.
- ▷ CHECK BRAKE LIGHTS
A lamp has failed or the electrical circuit has a fault. Refer to pages 186 and 196 or consult a BMW center.

- ▷ CHECK LOWBEAM LIGHTS
CHECK SIDE LIGHTS
CHECK REAR LIGHTS
CHECK FRONT FOGLAMPS
CHECK LICPLATE LIGHT
CHECK HIGHBEAM LIGHTS
CHECK BACK UP LIGHTS
Defective bulb or circuit. Refer to pages [183](#) and [196](#) or consult your BMW center.
- ▷ TRANS. FAILSAFE PROG
Please consult the nearest BMW center. Refer to pages [74](#), [77](#).
- ▷ CHECK BRAKE LININGS
Have the brake pads inspected by your BMW center. Refer to page [146](#).
- ▷ CHECK COOLANT LEVEL
Coolant too low, top up at the next opportunity. Refer to page [167](#).
- ▷ ENGINE FAILSAFE PROG*
The electronics allow for continued driving with reduced engine output or rpms.
Please have the system inspected by your BMW center.

Displays after completion of trip

All of the malfunctions registered during the trip appear consecutively when the key is turned to position 0.

One of the following displays may appear:

- ▷ LIGHTS ON
- ▷ KEY IN IGNITION LOCK
- ▷ CHECK ENGINE OIL LEV
Add engine oil at the next opportunity (next stop for fuel). Refer to page [165](#).

Display appears when you open the driver's door after parking the vehicle. A supplementary gong is also heard.

Status reports remain available for a period of approx. three minutes after the display goes out and the key is removed from the ignition. Press the CHECK button. If there were multiple reports, press the CHECK button repeatedly to view them all in sequence.

To check the Check Control

Press the CHECK button 3 with the ignition key in position 2: CHECK CONTROL OK appears in the display.

No malfunctions are present in the monitored systems.



You can have the Check Control messages displayed in a different language. ◀



Mode selection

From ignition key position 1 and up, you can call up information from the computer using the button in the turn signal lever. By pressing the button briefly in the direction of the steering column, you can call up a new function for display.

The displays appear in the following order: outside temperature, average fuel consumption, cruising range, average speed.

Starting with ignition key position 1, the last active setting is displayed.

The range of available displays varies according to your individual vehicle's equipment.



Outside temperature and average fuel consumption

You can change the units of measure (°F/°C) for the outside temperature display by

- 1 pressing and holding the trip odometer reset button (in ignition key position 1)
- 2 and then turning the ignition key to 0.

Refer also to page [83](#).



Cruising range and average speed

The computer bases its calculations of the cruising range on the previous driving style and conditions.

The computer ignores any time spent with the vehicle stationary and the engine off in its average speed calculations.

Cancel display

If the button in the turn signal lever is pressed briefly while the average speed is displayed, the computer display can be hidden.

To restart calculations

If you continue to press the button in the turn signal lever, the average values which were just displayed for fuel consumption and speed will be recalculated from that point (the engine must be running for this).

Central display

The MID serves as the central display and operation for the following onboard systems:

- ▷ Digital clock (e.g. time display, date)
- ▷ Audio systems (radio, cassette, CD)
- ▷ Computer (e.g. fuel consumption, cruising range)
- ▷ Cellular phone (e.g. dialing)

You will find explanations and notes for operating the digital clock and the computer on the following pages. Please refer to the separate Owner's Manual for operating the audio systems, the cellular phone and the onboard monitor.

 Any unrealistic numerical entries will not be accepted.

All stored data will be lost if the power supply is interrupted. Time display, switch-on times for independent heating and ventilation, distance and cruise control speed limit may have to be reset once the power supply has been re-established. ◀

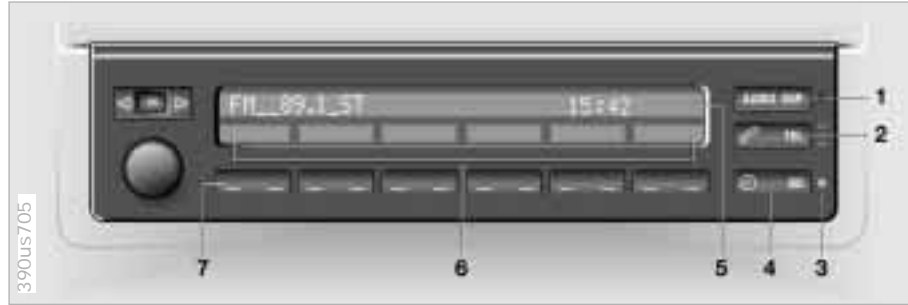

- 1 Function button for audio systems
- 2 Function button for the cellular phone*
- 3 Indicator lamp for independent ventilation*
 - ▷ remains on if switch-on time is active
 - ▷ flashes while operating
- 4 Function button for the digital clock and computer
- 5 Indicator display for the various computer systems
- 6 Display for the entry and display buttons. Depending on the operating mode, the functions and alternatives which can be selected at the buttons are displayed here
- 7 Entry and display buttons for operating the various computer systems

92 Digital clock in the MID*

 Only make inputs when the vehicle is standing still – to avoid endangering yourself or other road users. ◀

To call up time or date



Press the left side of the button.

Display shows:



You can have the time displayed in 12 or 24 hours.

To change the display:



Press the left side of the button.

If the 12-hour time display is in use, AM or PM appear after the time.

Changing the time display



Press the left side of the button.



Press on the right side:
The dots flash in the display.

To alter the setting:



Press on the left or right, or hold the button down.

To store the input:



Press the right side of the button.

To change the date



Press the left side of the button.



Press.



Press on the right side:
The dots and the DATE display flash.

To alter the setting:



Press on left or right, or hold the button down.

To store the input:



Press the right side of the button.

The clock takes leap years into account and therefore does not have to be reset manually.

Reminder signal

You can program a reminder signal (Memo) to be heard every hour, so that you are sure not to miss a news broadcast.



Press the left side of the button.



Press.

MEMO OFF appears in the display for entry and query buttons, and the tone symbol will appear in the upper right of the display.

A signal is then heard 15 seconds before each hour.

Timer



Press the left side of the button.



Press.

Display shows:



To start the stopwatch function:



Press the right side of the button.

To take an intermediate time reading:



Press.



Press.

The stopwatch display can be seen counting up; the stopwatch continues to run.

To halt the stopwatch:



Press the right side of the button.

 The stopwatch is halted when the ignition switch is turned back to 0, but starts to run again when the ignition key is turned to 1. ◀

94 Digital clock in the MID*

Enter the switch-on times for the independent ventilation*

You can enter two different switch-on times.

The ventilation will shut off automatically after 30 minutes.

 Please follow the instructions for operating the independent ventilation that start on page [120](#). ◀



Press the left side of the button.



Press on the left/right.

Display shows:



Press on the right:
Display flashes, e.g. TIMER 1.

To input the time:



Press on the left or right, or hold the button down.

To confirm the input:



Press the right side of the button.

The activated time is marked with an asterisk.



The switch-on times remain memorized until new inputs are made.

You can change switch-on times that have already been memorized by making a new time input as described above.

When the switch-on time is active, the LED comes on in the MID. During actual operation of the ventilation, the LED flashes. The LED goes out when the system is switched off.

To activate/deactivate the time:



Press twice.

Directly switching the independent ventilation* on and off

 The independent ventilation function can only be called up in ignition key position 1. ◀



Press the left side of the button.



Press.

or



Press.

Computer in the MID*

 Only make inputs when the vehicle is standing still – to avoid endangering yourself or other road users. ◀

Computer calculations begin at the start of the journey.
Information can also be called up in the display by remote control, refer to page 99.

Speed limit

Speed limit input:

You can input the road speed here at which you wish to hear and see a reminder signal: a signal will sound, the word LIMIT will flash, and for a moment, the speed limit warning stored in the memory will appear on the instrument cluster as an alphanumeric display*, along with the Check Control.

The speed limit reminder is only repeated if the vehicle has in the meantime been driven at least 3 mph (approx. 5 km/h) slower.



Press the right side of the button.



Press.



Press the right side of the button.

Display shows:



Input the limit by pressing the function buttons.

To correct an entry:



Press on the left and repeat the input.

To store the input:



Press the right side of the button.

96 Computer in the MID*

Adopting the current speed as the speed limit:



Press the right side of the button.



Press.



Press twice at right.

Deactivating the speed limit:



Press the right side of the button.



Press.

The LIMIT display goes out, but the memorized value is not lost and can be re-activated by pressing the LIMIT button.

Distance from destination

The remaining distance to the destination will be displayed on the screen. This is of course only possible if you entered the entire distance before starting the journey.

Input:



Press the right side of the button.



Press the left side of the button.



Press the right side of the button.

Display shows:



You can input the distance by pressing the function buttons.

To correct an entry:



Press on the left and repeat the input.

To store the input:



Press the right side of the button.

Checking memorized value:



Press the right side of the button.



Press the left side of the button.

Estimated time of arrival

When you have input the distance from your destination, you can obtain an estimated time of arrival display which is continuously updated by the computer as your average driving period varies.



Press the right of the button.



Press on the right:
The estimated time of arrival is displayed.

Cruising range

The distance which the vehicle should cover on the remaining fuel in the tank is displayed.



Press the right of the button.



Press.
The display shows the probable range.



When you have only enough fuel left to drive fewer than 30 miles (50 km), then refuel, as otherwise the engine or the catalytic converter could be damaged. ◀

The computer will only register fuel amounts over 1.8 gal (6 liter).

Fuel consumption

You can have the average fuel consumption displayed for two different distances, for example a complete journey and part of the journey.

To start the calculation, select the CONS function with the engine running.



Press the right side of the button.



Press on the left or right:
The display will show the average fuel consumption.

To restart the fuel consumption calculation:



Press on the left or right.



Press the right side of the button.

Speed

You can call up a display of the vehicle's average speed.

To start the calculation, select the SPEED function with the engine running.



Press the right side of the button.



Press.

The display shows the average speed.

To recalculate the speed:



Press the right side of the button.

Extended immobilizer function

You can establish a code that will prevent the engine from being started unless the code is entered.

If you do not have access to the code, the emergency de-activation procedure will have to be carried out.

Establishing and activating the code:



Press the right side of the button.



Press the left side of the button.

Display shows:



Enter the code with the function buttons.

To correct an entry:



Press on the left and repeat the input.

To store the input:



Press the right side of the button.
Turn the ignition key to position 0.

Deactivate the code.

When you are asked to input the code (ignition key in position 1 or 2):

▷ Input the code at the function buttons.



Press the right side of the button.

After the code has been input correctly and confirmed with the SET button, the time display appears.

Computer in the MID*

After three incorrect code inputs, or three attempts to start the engine without a code input, the alarm will sound for 30 seconds on vehicles fitted with an alarm.

Deactivating the alarm in an emergency:

If you have forgotten the code, proceed as follows:

- 1 Disconnect the battery, wait approx. 2 minutes, then reconnect it. Note that on vehicles with an alarm, this will sound.
- 2 Set the ignition key to position 1: The time display will count down for the next ten minutes.
- 3 After ten minutes, start the engine.

 If the code becomes available again in the meantime, it can be input during the waiting period after pressing the CODE button. ◀



Remote control

The button on the turn signal indicator lever can be used to select the items of computer information which are to be displayed.

To do this, press

- ▷ the button on the lever until PROG 1 shows on the display
- ▷ the MID buttons in the order in which you wish the information to be displayed.

Each time an entry is stored, the program number appears on the display.

To terminate the selection procedure:



Press the right side of the button.

To have all the available information displayed, press

- ▷ the button on the lever until the display shows PROG 1
- ▷ the SET button.

To obtain individual items of information, press the button in briefly as often as necessary.

The concept

The PDC assists you when you are parking. A signal warns you of the real distance to an obstacle. To do this, four ultrasonic sensors in the front and rear bumpers measure the distance to the nearest object. The monitoring range for the front and both rear corner sensors extends approx. 2 ft (60 cm) beyond the bumper. The range for the center rear sensors extends approx. 5 ft (1.50 meters).

Automatic operation

The system starts to operate automatically approx. one second after you select reverse or move the selector lever into the "R" position with the ignition key in position 2.

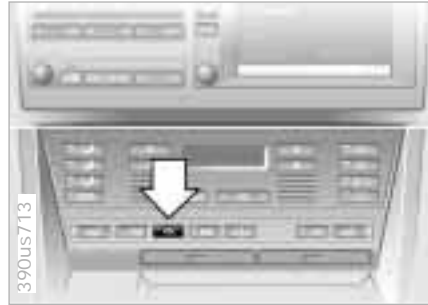

Turn on manually

Press the button (arrow), the indicator lamp comes on.

After driving more than approx. 160 ft (50 meters) or exceeding approx. 20 mph (30 km/h), the system switches off and has to be switched back on when you want to use it again.

Acoustic signals

The distance to an object is indicated by a high beeping sound in the front and a low beeping sound in the back. As the distance between vehicle and object decreases, the intervals between the tones become shorter. A continuous tone indicates the presence of an object less than 1 ft (30 cm) away.

The warning signal will be canceled after approx. 3 seconds if the distance to the obstruction remains constant during this time (if you are moving parallel to a wall, for instance).

Malfunction in the PDC system:

The indicator lamp flashes and a brief continuous signal tone is heard

- ▷ when the PDC system is activated via the button
- ▷ when you first select reverse or move the selector lever into the "R" position after switching on the ignition
- ▷ when there is a malfunction while the PDC system is active.

Switch the system off and have the cause of the malfunction corrected by your BMW center.

 The PDC does not remove the driver's personal responsibility for evaluating the distance between the vehicle and any obstacles. Even when sensors are involved, there is a blind spot in which objects cannot be detected. This applies especially in those cases where the system approaches the physical limits of ultrasonic measurement, as occurs with tow bars and trailer couplings, and in the vicinity of thin and painted objects. Certain sources of sound, such as a loud radio, could drown the PDC signal tone. ◀

 Keep the sensors clean and free of ice or snow in order to ensure that they continue to operate effectively. Do not apply high pressure spray to the sensors for a prolonged period of time. Maintain an adequate distance of more than approx. 4 in (10 cm). ◀

Automatic Stability Control plus Traction (ASC+T)/Dynamic Stability Control (DSC)*

These systems contribute to additional vehicle stability, especially during acceleration and when cornering.

The DSC system enhances the benefits of the ASC+T. In addition to optimizing vehicle stability and traction during acceleration or when starting from a standstill, a further benefit is realized in cornering. This, of course, is true only within physically feasible limits.

The system activates automatically each time you start the engine.

Indicator lamp



The indicator lamp in the instrument cluster goes out shortly after you switch on the ignition.

Refer to page 24.

Indicator lamp flashes:

The system is active and governs drive and braking forces.

If the indicator lamp fails to go out after the engine is started, or if it comes on during normal driving:

There is a system malfunction or the system was deactivated with the button. You can still drive the vehicle normally without ASC+T/DSC. Please consult your BMW center for repairs.



To deactivate the system

Press the button (arrow). The indicator lamp will come on.

Depending on equipment options, the button is marked with ASC or DSC.

With deactivated ASC+T/DSC you are driving with conventional, unregulated torque transfer.

In the following exceptional situations, it may be effective to deactivate the ASC+T/DSC for a brief period:

- ▷ When rocking the vehicle or starting off in deep snow or on loose surfaces.
- ▷ When driving with snow chains.
Refer also to page 147.

To reactivate the system

Press the button again; the indicator lamp goes out.

 The laws of physics cannot be repealed, even with ASC+T/DSC. An appropriate driving style always remains the responsibility of the driver. We therefore urge you to avoid using the additional safety margin of the system as an excuse for taking risks. ◀

For additional details concerning ASC+T/DSC, please refer to the chapter describing "Advanced technology" on page 207.

The concept

RDC monitors the tire pressures at all four wheels, even when the vehicle is moving. The system provides an alert whenever the inflation pressure drops significantly below the specified pressure in one or more tires.

In order for the system to "learn" the correct tire inflation pressure, check the inflation pressure in all tires. Refer to the table of "Tire inflation pressures" beginning on page 29 and make any necessary corrections. Then activate the system.



This indicator lamp in the instrument cluster or the Check Control will inform you if the tire pressure is not correct.



Activate the system

- 1 Turn the ignition key to position 2 (do not start the engine).
- 2 Press and hold the button (arrow) until the yellow indicator lamp in the instrument cluster comes on for a few seconds or the message "SET TIRE PRESSURE" appears in the Check Control.
- 3 After you have driven for a few minutes, the RDC will import the current inflation pressure in the tires as the target values which the system will monitor.

You will only have to repeat this procedure if the tire inflation pressure must be corrected. Otherwise, the RDC functions automatically when the ignition key is in position 2, and thus operates whenever the vehicle is driven.

Loss of tire pressure

If, after a certain period of time, the air pressure has gone down significantly (which is normal for any tire), the yellow indicator lamp comes on or the message "CHECK TIRE PRESSURE" appears in the Check Control.

This alerts you that you should have the tires inflated to the specified pressures as soon as possible.

 If you are prompted to check the tire pressure shortly after a correction has been made, this indicates that the corrected values were not accurate. Please check the inflation pressure again and make corrections according to the inflation pressure table. ◀

Flat tire

If there is a tire failure with a loss of air pressure, the red indicator lamp comes on or the message "TIRE DEFECT" appears in the Check Control. In addition, a gong sounds.

If this occurs, reduce vehicle speed immediately and stop the vehicle in a safe location. Avoid hard brake applications. Do not oversteer. Replace the flat tire.

 The spare tire which is available in your vehicle as standard equipment is equipped with the electronics required for RDC and, following activation of the system, is also monitored after it is mounted. ◀

 The RDC cannot alert you to severe and sudden tire damage caused by external factors. ◀

 Have the tires changed by your authorized BMW center. Your BMW center has the information needed for working with RDC and is equipped with the necessary special tools. ◀

System interference

During the period of the malfunction, the yellow indicator lamp comes on or the message "TIRECONTROL INACTIVE" appears in the Check Control.

You will also see the same message

- ▷ in the event of a system fault
- ▷ if a wheel is mounted without the RDC electronics
- ▷ if, in addition to the spare tire, additional wheels with RDC electronics are on board.

Please contact your BMW center for additional information.



"Follow-me-home lighting:"
If you actuate the headlamp flasher after you have parked the vehicle and shut off the engine, the low beams will remain on for a brief period. You may also have this function deactivated if you wish. ◀

Xenon lamps*

For additional details, refer to page [184](#).

Parking lamps (side marker lamps)



With the switch in this position, vehicle lighting is illuminated on both sides. For lighting on one side for parking as an additional feature, refer to page [106](#).

Low beams/Xenon lamps*



When the ignition is switched off and the low beams are on, only the parking lamps (side marker lamps) remain on.

"LIGHTS ON" warning

In ignition key position 0, a buzzer sounds for a few seconds after the driver's door is opened if the headlamps have not been switched off.

On vehicles with alphanumeric Check Control*:

The reminder is given through the Check Control.

Daytime-driving lamp*

The headlamps are automatically switched on for daylight driving at ignition key position 2.



Turn the rotary dial to adjust the illumination intensity.



- 1 High beam (blue indicator lamp)
- 2 Headlamp flasher (blue indicator lamp)
- 3 Parking lamps

Parking lamp, left or right

As an additional feature, you can illuminate your vehicle on either side for parking, if you wish to do so:

With the ignition key in position 0, push the lever in the appropriate direction. The lever engages in the turn signal position.



Front fog lamps



A green indicator lamp comes on in the instrument cluster to indicate that the front fog lamps are on.

If the high beam is switched on, the fog lamps go out.

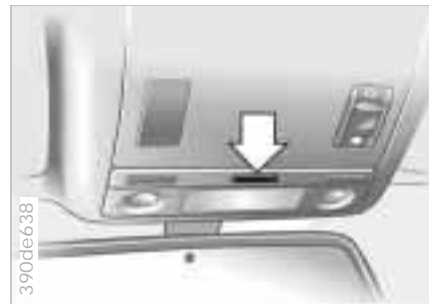

The interior lamps operate automatically.

Switching interior lamps on and off

Press the button (arrow).

If you want the interior lamps to remain off at all times, press and hold the button for approx. 3 seconds.

Press the button briefly to revert to normal operation.

The luggage compartment lamps in the sport wagon function in the same manner.

Interior lamps

Footwell lamps

The footwell lamps operate in the same way as the interior lamps.

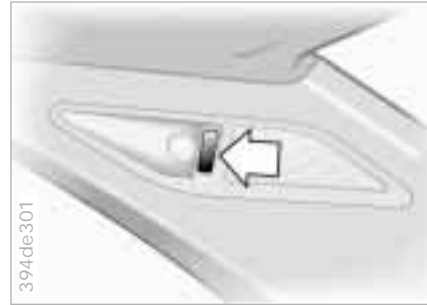



The reading lamps are located in the front near the interior lamp. There are also reading lamps in the rear. They can be switched on and off with the switch (arrow) adjacent to each lamp.

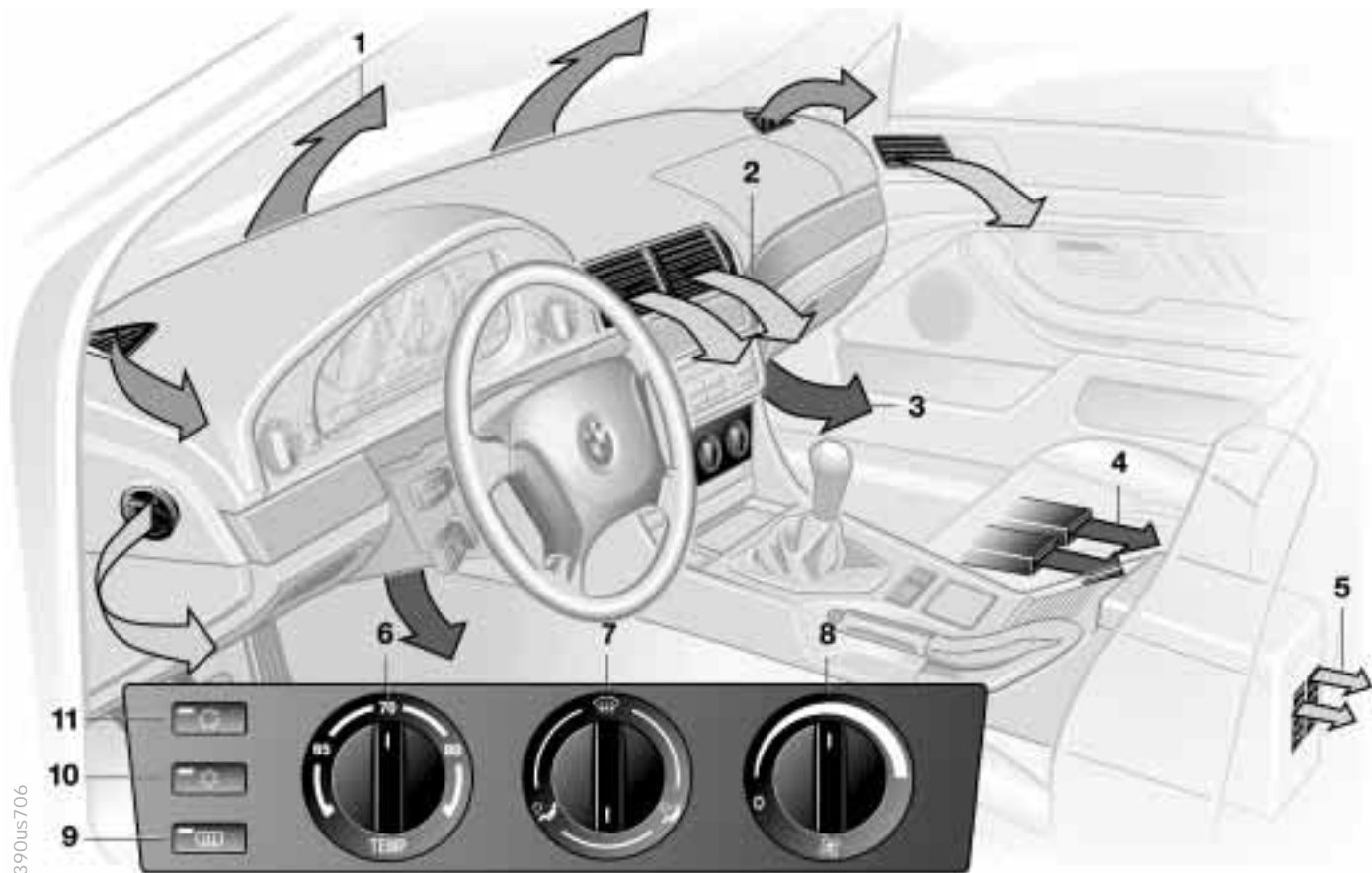

In order to conserve the battery, all of the lamps in the vehicle are switched off automatically approx. 15 minutes after the ignition key is turned to position 0. ◀



Air conditioner

- 1 Air flow directed toward the windshield and side windows
- 2 Air flow for the upper body
The side rotary dials allow you to open and close the air supply over an infinitely-variable range, while the levers change the airflow direction. The center rotary dial controls the temperature of the air as it flows out, refer to page [111](#)
- 3 Front footwell ventilation
- 4 Rear footwell ventilation
- 5 Airflow for the upper body in the rear [111](#)
- 6 Temperature [110](#)
- 7 Air distribution toward
 - ▷ the windows 
 - ▷ the upper body 
 - ▷ the footwell All intermediate settings are possible. Refer to page [110](#)
- 8 Air supply [110](#)
The climate control is active when the blower is switched on
- 9 Rear window defroster [110](#)
- 10 Cooling [110](#)
- 11 Recirculated air mode [111](#)

Tips for a pleasant driving experience

Temperature 6 is recommended for a comfortable setting at 70 °F (22 °C). Turn the air distribution 7 to the "6 o'clock" position. Adjust the air supply 8 to the center setting. Set the outlets 2 so that the air flows past you and is not directed straight at you. Set the rotary dial between the outlets 2 for the upper body to a central position so that cooler air helps prevent fatigue during the journey.

The following description will lead you through additional individual adjustments.





Temperature



The graduations on the dial provide general reference values for the interior temperature. We recommend 70 °F (22 °C) as a comfortable setting. When you start the vehicle, this system adjusts the air to the selected temperature as quickly as possible, and then maintains that temperature constantly.

Air distribution



You can direct air to flow onto the windows , toward the upper body  and into the footwell . You can also select all intermediate settings. In the  setting, there is a low flow of air onto the windows to keep them free of condensation. The "6 o'clock" setting is recommended for normal conditions (refer to the illustration and overview on page 108).

Air supply



You can adjust the air supply over an infinitely-variable range. The heating and ventilation become increasingly effective as the air supply settings are increased. In the "0" setting, the blower and climate control are switched off and the outside air supply is blocked.

Rear window defroster



When the rear window defroster is activated, the indicator lamp comes on. The rear window defroster switches off automatically.

Cooling



The air is cooled and dehumidified and – depending on the temperature setting – warmed again with the air conditioner system switched on. Depending on the weather, the windshield may fog over briefly when the engine is started. Switch off the air conditioner at outside temperatures below approx. 42 °F (5 °C). This will help to prevent the windows from fogging up. If the windows fog over after switching the air conditioner off, switch it back on.



Condensation forms in the air conditioner system during operation, which then exits under the vehicle. Traces of condensed water of this kind are thus normal. ◀

Air conditioner

Recirculated air mode



If there are unpleasant odors in the outside air, you can temporarily block the flow of air. The system then recirculates the air currently within the vehicle.

If you have a multifunction steering wheel with the button for recirculated air, you can also use this button to switch to the recirculated air mode (refer to page 25).



If the windows fog over in the recirculated air mode, switch the recirculated air off and increase the air supply as required. ◀

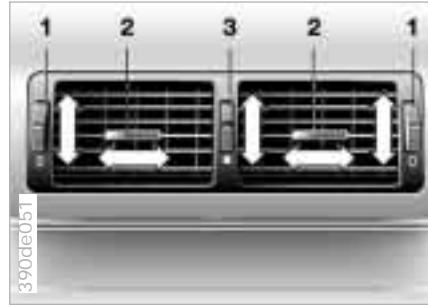

Draft-free ventilation

You can adjust the blower controls for the upper body area to select the optimum airflow rates and directions for your personal requirements:

Use the rotary dials 1 to open and close the air outlets over an infinitely-variable range. You can adjust the direction of the airflow using the rotary dial 2.

Set the air outlets so that the air flows past you and is not directed straight at you.

Rotary dial 3 allows you to control the temperature of the airflow from these outlets as desired:

- ▷ Turn toward blue – colder.
- ▷ Turn toward red – warmer.

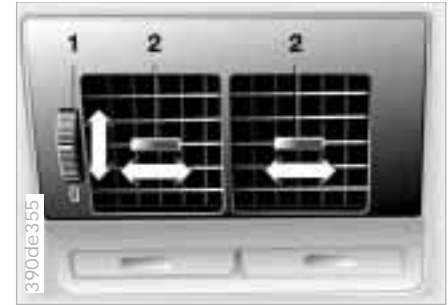

Rear passenger area ventilation

Rotary dial 1 opens the outlets over an infinitely-variable range. You can change the direction of the airflow with the levers 2.

The air that flows out here is somewhat cooler than the air delivered to the footwell.

Microfilter

The microfilter removes dust and pollen from the incoming air. Your BMW center will replace it during routine maintenance. A substantial reduction in airflow indicates that the filter needs to be replaced early.

**Cooling**

- 1 You can specify an interior temperature comfortable for you, e.g. 70 °F (22 °C) by turning the rotary temperature dial.
- 2 Switch on the air conditioner.
- 3 Set the air distribution rotary dial to .
- 4 Set the blower/air supply rotary dial to the middle zone.
- 5 Open the air outlets for the upper body.
- 6 Select a temperature that is comfortable for you with rotary dial 3. Refer to "Draft-free ventilation" on page [111](#).

Rapid ventilation

- 1 You can specify an interior temperature comfortable for you, e.g. 70 °F (22 °C), by turning the rotary temperature dial.
- 2 Switch on the air conditioner and recirculated air mode.
- 3 Set the air distribution rotary dial to .
- 4 Turn the blower/air supply rotary dial completely to the right.
- 5 Open the air outlets for the upper body.
- 6 Set rotary dial 3 to cold (blue). Refer to page [111](#).



Rapid heating

- 1 You can specify an interior temperature comfortable for you, e.g. 70 °F (22 °C), by turning the rotary temperature dial.
- 2 Set the air distribution rotary dial to .
- 3 Turn the blower/air supply rotary dial completely to the right.
- 4 Close the air outlets in the rear passenger area.

To defrost windows and remove condensation

- 1 You can specify an interior temperature comfortable for you, e.g. 70 °F (22 °C), by turning the rotary temperature dial.
- 2 Set the air distribution rotary dial to .
- 3 Turn the blower/air supply rotary dial completely to the right.
- 4 Close the air outlets in the rear passenger area.
- 5 Switch on the rear window defroster to defrost the rear window.

Heating

When the windows are free of ice and condensation, we recommend the following settings:

- 1 You can specify an interior temperature comfortable for you, e.g. 70 °F (22 °C), by turning the rotary temperature dial.
- 2 Set the air distribution rotary dial to .
- 3 Set the blower/air supply rotary dial to the middle zone.
- 4 Close the air outlets in the rear passenger area.

114 Automatic climate control*

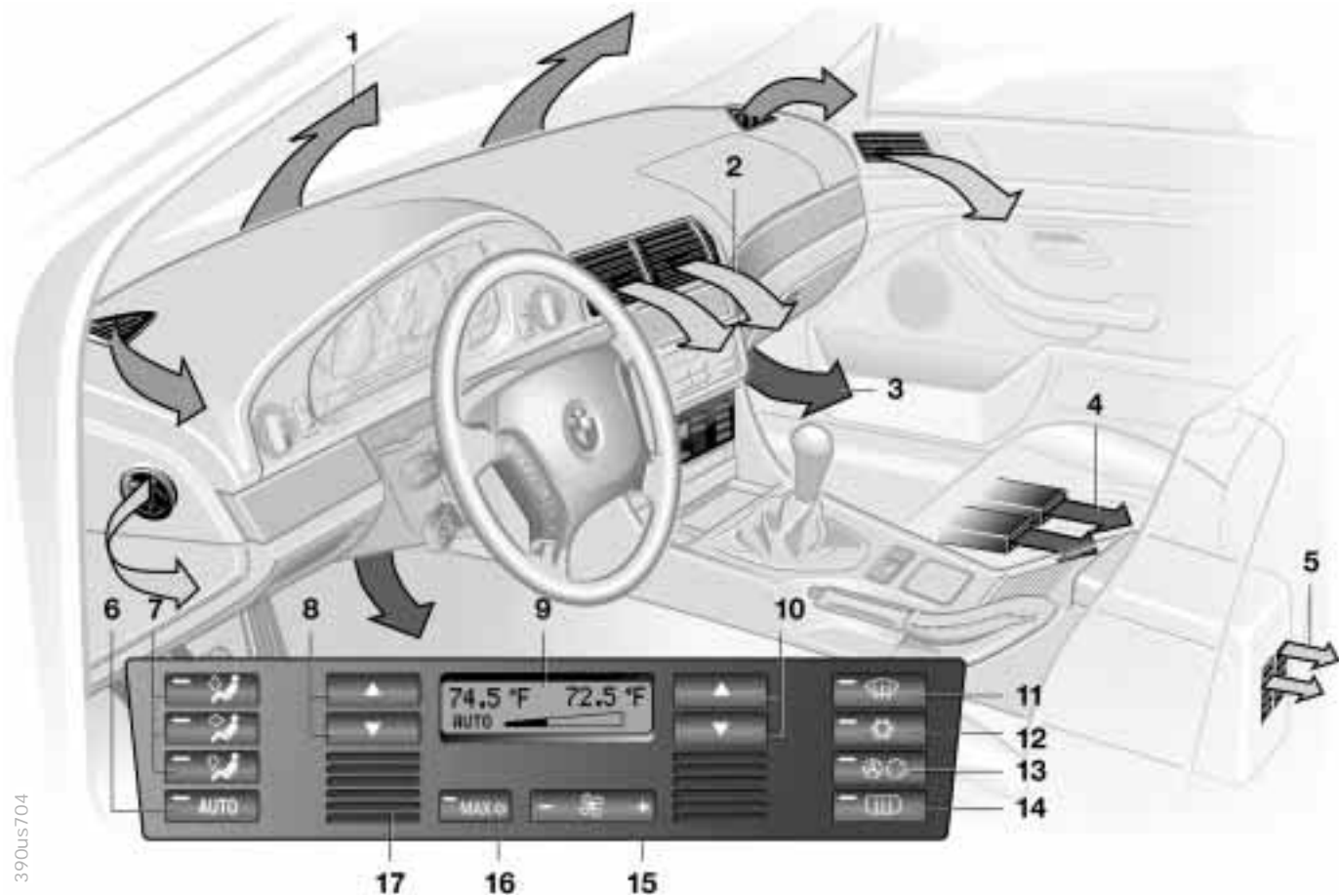

- 1 Airflow directed toward the windshield and side windows
- 2 Airflow for the upper body
The side rotary dials provide infinitely-variable regulation of the air supply, while the levers change the airflow direction. The center rotary dial controls the temperature of the air as it flows out [118](#)
- 3 Front footwell ventilation
- 4 Rear footwell ventilation
- 5 Airflow for the upper body in the rear [118](#)
- 6 Automatic air distribution [116](#)
- 7 Individual air distribution [116](#)
- 8 Temperature control – left-hand side [116](#)
- 9 Display for temperature and air supply [116](#), [117](#)
- 10 Temperature control – right-hand side [116](#)
- 11 To defrost windshield and windows [117](#)
- 12 Air conditioner [117](#)
- 13 Automatic recirculated air control AUC [117](#)
- 14 Rear window defroster [80](#), [118](#)
- 15 Air supply [117](#)
- 16 Maximum cooling [117](#)
Residual heating mode [118](#)
- 17 Air grill for interior temperature sensor – please keep clear and unobstructed

Tips for pleasant driving

Use the automatic system, that is, press AUTO button 6. Select an interior temperature that is comfortable for you – we recommend 70 °F (22 °C). When the outside temperature is above 41 °F (5 °C), you can also use the air conditioner 12. This will dry the air and prevent the window from fogging (for example if people are wearing damp clothes in the vehicle). Set the outlets 2 so that the airflows past you and is not directed straight at you. Set the rotary dial between the outlets 2 for the upper body to a central position. This will provide cooler air, and help to prevent fatigue during the journey.





Detailed setting options are described for you in the following section.

 You can make the settings of your vehicle in such a manner that, when you unlock the vehicle with the remote control of your personal key, your own personalized setting for the automatic climate control is initiated. ◀

Automatic air distribution

 The AUTO program assumes the adjustment of the air distribution and the air supply for you and also adapts the temperature to external influences (summer, winter) to meet preferences you can specify. This program maintains a comfortable in-car climate regardless of the season. Select an interior temperature that is pleasant for you – we recommend 70 °F (22 °C). The selected temperature and AUTO for the airflow appear in the display 9. Refer to the overview on page 114. Open the ventilation outlets for the upper body. Switch on the air conditioner 12 in warm weather. The maximum cooling capacity is achieved when you set the rotary dial 3 (refer to page 118) to cold.

Individual air distribution

 You can cancel the AUTO program by selecting specific distribution patterns to suit your own individual requirements. You can direct air to flow onto the windows , toward the upper body  and into the footwell .

Temperature

 You can make individual temperature settings on the driver's side or the front passenger side. Your settings will be shown in the display 9. The displayed temperatures are reference values for the interior temperature. We recommend 70 °F (22 °C) as a comfortable setting, whether the air conditioner is operating or not. When you start the vehicle, the system ensures that the selected temperature is achieved as quickly as possible. It then maintains this temperature, regardless of the season.

Set the rotary dial 3 (refer to "Draft-free ventilation" on page 118) to a medium position to provide somewhat cooler air. This helps to promote driving without fatigue. Make use of this means of mixing air especially for making minor adjustments for personal comfort.

 You can set uncontrolled heater output at up to 90 °F (32 °C). Full cooling output is available from the air conditioner down to 60 °F (16 °C). ◀

Air supply

 In the "AUTO" program, the airflow is controlled automatically. AUTO will appear in the display 9 (refer to the overview on page 114). Use "+" and "-" to vary the airflow. When your setting is displayed by bars, the automatic airflow is switched off. Automatic air distribution maintains its setting. You can reactivate the automatic airflow by pressing the "AUTO" button.

When you press "-" during operation at minimum blower speed all displays are canceled: the blower, heating and air conditioner are switched off. The outside air supply is closed. By pressing any button of the automatic climate control (except the "MAX" button 16), you can switch the system back on.

To defrost windshield and windows

 This program quickly removes ice and condensation from the windshield and the side windows.

Air conditioner

 The air is cooled and dehumidified and – depending on the temperature setting – warmed again when the air conditioner system is switched on. Depending on the weather, the windshield may fog over briefly when the engine is started. Use the button to switch off the air conditioner at outside temperatures below approx. +41 °F (+5 °C). This will help to prevent the windows from fogging up. If the windows fog over after switching the air conditioner off, switch it back on.

 Condensation forms in the air conditioner system during operation, which then exits under the vehicle. Traces of condensed water of this kind are thus normal. ◀

Maximum cooling

 You will get maximum cooling capacity using this program if the engine is running and the outside temperature is above +41 °F (+5 °C).

The temperature display 9 jumps to +61 °F (+16 °C), the system switches over to the recirculated-air mode, and the air will only stream out of the ventilation grill with the maximum amount of air flow. That is why you need to keep these open if you select this program.

Automatic recirculated-air control (AUC)

 You can respond to unpleasant external odors by temporarily stopping the flow of outside air. The system then recirculates the air currently within the vehicle. Press the button repeatedly to run through the following control sequence:

- ▷ Indicator lamps off: outside airflow operational.

- ▷ Left-hand indicator lamp on – AUC mode: the system recognizes pollutants in the outside air and blocks the flow of air when necessary. The system then recirculates the air currently within the vehicle.

Depending on the air quality, the automatic system then switches back and forth between outside air supply and recirculation of the air within the vehicle.

- ▷ Right-hand indicator lamp on: the flow of external air into the vehicle is permanently blocked. The system then recirculates the air currently within the vehicle.

If you have a multifunction steering wheel with the recirculated-air button (refer to page 25), you can also use it to switch between "Off" and the recirculated-air mode or AUC and the recirculated-air mode.

 If the windows should fog over in the recirculated air mode, switch the recirculated air mode off and increase the air supply as required. ◀

Rear window defroster



When the rear window defroster is activated, the indicator lamp comes on. The rear window defroster switches off automatically.

Residual heating mode



The heat which is stored in the engine is utilized for heating the interior when the engine has been switched off (while waiting at a railroad crossing, for instance).

In ignition key position 1, you can alter the settings of the automatic climate control. In ignition key position 0, the system automatically directs heated air to the windshield, side windows and footwells.

 This function may be activated when the outside temperature is below approx. 59 °F (15 °C), the engine is at operating temperature, and the battery is adequately charged. The LED on the button will light up when all conditions have been met. ◀

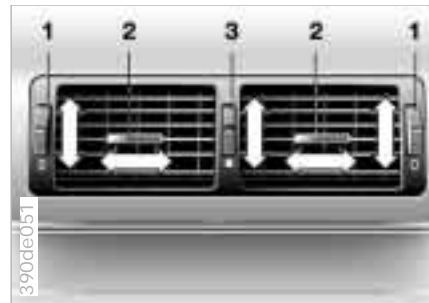

Draft-free ventilation

You can adjust the blower controls for the upper body area to select the optimum airflow rates and directions for your personal requirements:

Use rotary dial 1 to open and close the airflow through an infinitely-variable range. You can also use the levers 2 to change the direction of the airflow.

Set the outlets so that the air flows past you and does not flow directly onto you.

Rotary dial 3 allows you to adjust the airflow from these outlets by adding heat or cooling as desired:

Turn toward blue – colder.
Turn toward red – warmer.



Rear passenger area ventilation

Rotary dial 1 opens the outlets in an infinitely-variable range. You can vary the temperature of the air as it flows out using rotary dial 3 in the same manner as for the front rotary dial.

You can change the direction of the airflow with levers 2.

Microfilter, activated-charcoal filter

The microfilter removes dust and pollen from the incoming air. The activated-charcoal filter provides additional protection by filtering gaseous pollutants from the outside air. Your BMW center replaces this combined filter as a standard part of your scheduled maintenance. A substantial reduction in airflow indicates that the filter must be replaced before scheduled maintenance.



The seat cushion and backrest can be heated with the ignition key in position 2.

You can call up different heating modes by repeatedly pressing the keys.

The highest heating mode is on when the three indicator lamps are lit; one lamp is lit for lowest heating. Temperature regulation in each mode is with a thermostat.

You can also switch the higher heating modes off directly: Press the key and hold it slightly longer.

120 Steering wheel heating*



To activate and cancel the steering wheel heater, press the button (arrow) with the ignition key in position 2.

The lamp within the button lights up when the steering wheel heater is in operation.

If you have a multifunction steering wheel without steering wheel heating, the button for the recirculated-air mode is in this location (refer to page 25).

Roller sun blind*

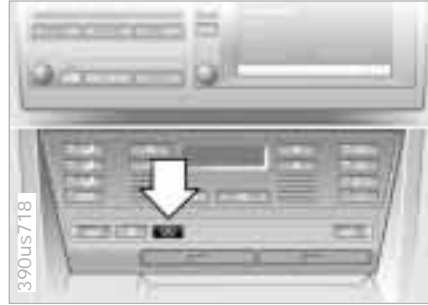

To operate, press the key briefly with the ignition key in position 1 or 2.

Roller sun blinds for rear side windows*

Use the strap to extract the blinds, then hook them in the attachment provided.

Independent ventilation*

This system allows you to ventilate the interior and lower its temperature, using the blower of the automatic climate control.

The independent ventilation system is operated via the Multi-Information Display (MID) – refer to page 94 – or the onboard monitor. Refer to the separate Owner's Manual.

You can set two different times for the system to start; it will remain active for 30 minutes. You can also turn it on and off directly. Since the system uses a substantial amount of electrical current, you should not activate it twice in succession without allowing the battery to be recharged in normal operation between use.

When a preselected activation time is set, the independent ventilation system is operational at outside temperatures above 60 °F (16 °C), or by direct switch activation. It cannot be switched on when the vehicle is moving.

The air emerges via the vent outlets for the upper body. Therefore, the vents must be open for the system to operate.

The concept

The BMW Universal Transmitter replaces up to three hand-held transmitters that control different devices such as a garage door opener, alarm systems or a door locking system. The BMW Universal Transmitter recognizes and "learns" the transmitted signal from each of the original hand-held transmitters.

The signal of an original hand-held transmitter can be programmed to one of three channel buttons. Following that, each of the devices can be operated with the channel button that you have programmed for it. A transmission of the signal is indicated by the indicator lamp.

Before you sell your vehicle, the programmed channel buttons should be cleared. Refer to page 123 for the description of this process.

 To prevent potential injuries or damage during the programming operation and before every remote triggering of a programmed device using the BMW Universal Transmitter, be sure that there are no persons, animals or objects within the range of movement of the respective device.

Read and comply with the safety instructions for the original hand-held transmitter also. ◀

 To Canadian residents:
During programming, your hand-held transmitter may automatically stop transmitting after two seconds. This may not be long enough to program the BMW Universal Transmitter. If you are programming from one of these hand-held transmitters, the Universal Transmitter's lamp may begin to flash in a series of double flashes. If this occurs, continue to hold the button on the Universal Transmitter while you reactivate your hand-held transmitter. You may have to repeat this function several times while programming. ◀

 Before programming, read the "User's information" section on page 123. ◀

The original hand-held transmitter

 If this symbol is depicted on the packaging or in the user's instructions for the original hand-held transmitter, it may be assumed that this original hand-held transmitter is compatible with the BMW Universal Transmitter.

Checking for the change code

In order to determine whether the original hand-held transmitter is equipped with a change code system, you may either refer to the instructions for the original hand-held transmitter or program a channel button as described in the left column on page 122 under "Programming."

Following that, press and hold the programmed channel button of the BMW Universal Transmitter. If the indicator lamp of the BMW Universal Transmitter flashes rapidly for two seconds and then stays on continuously, the original hand-held transmitter is equipped with a change code system. If the change code system is available, program the channel buttons as described in the right-hand column on page 122 under "Programming a hand-held transmitter with change code."

 If you have additional questions, please consult your BMW center or call 1-800-355-3515. ◀



Programming

- 1 Channel buttons
- 2 Indicator lamp
- 3 Receiver for programming

 Read and comply with the safety precautions on page 121. ◀

- 1 Ignition key in position 2.
- 2 For initial operation: press and hold the two outer buttons 1 until the indicator lamp 2 flashes. Release the buttons. The three channel buttons are cleared.

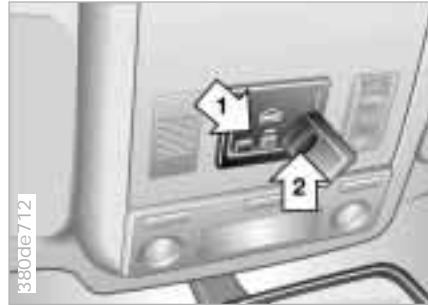

- 3 Hold the original hand-held transmitter at the receiver 3 a maximum of 2 in (5 cm) away.
- 4 Simultaneously press the transmitting key of the original hand-held transmitter (arrow 2) and the desired channel button of the BMW Universal Transmitter (arrow 1). Release both buttons as soon as the indicator lamp flashes rapidly.
- 5 To program other original hand-held transmitters, repeat steps 3 and 4.

The corresponding channel button is now programmed with the signal of the original hand-held transmitter.

Programming a hand-held transmitter with change code

 Read and comply with the safety precautions on page 121. ◀

Consult the operating instructions for the individual device when programming the BMW Universal Transmitter. Read and comply with the following programming instructions for the use of the BMW Universal Transmitter with a change code system:

 A second person simplifies programming of the BMW Universal Transmitter. ◀

- 1 Program the BMW Universal Transmitter as described above under "Programming."
- 2 Press and hold the programming button on the receiver of the device for about two seconds or until the programming lamp on the device comes on.
- 3 Press the desired channel button of the BMW Universal Transmitter three times.

 If you have additional questions, please consult your BMW center. ◀

Clearing the channel buttons



Read and comply with the safety precautions on page 121. ◀

Individual channel buttons cannot be cleared. However, the three channel buttons can be cleared together in the following manner:

- ▷ Press and hold the two outer channel buttons of the BMW Universal Transmitter until the indicator lamp flashes, and then release the buttons.

All channel buttons are cleared.

User's information

Do not use this BMW Universal Transmitter with any garage door opener that lacks safety "stop" and "reverse" features as required by federal safety standards (this includes any garage door opener model manufactured before April 1, 1982).

This device complies with Part 15 of the FCC Rules. Operation is subject to the following two conditions:

- (1) This device may not cause harmful interference, and
- (2) This device must accept any interference received, including interference that may cause undesired operation.

**To open**

Pull the handle and the lamp comes on.

To close

Fold the cover up.

To lock

Use one of the master keys to lock the vehicle. A master key is also required for unlocking.

 For example, if you turn over only your door and ignition keys for valet parking (refer to page 36), access to the glove compartment is not possible. ◀

 To prevent injury in the event of an accident, close the glove compartment immediately after use. ◀

Rechargeable flashlight*

Located on the left-hand side of the glove compartment. Features integral overload-protection, so it can be left in its holder continuously.

 Be sure that the flashlight is switched off when it is inserted into its holder. Failure to comply with this precaution could lead to overcharging and damage. ◀



The cover of the storage compartment on the vertical surface of the center console can be pushed open or closed (illustration). If your vehicle is equipped with a cassette holder*, open each cassette compartment by pressing on the small button.

Storage compartment on the center console between the front seats: to open, reach into the recess at the front and pull upward.

You will find a coin holder in the door pocket on the driver's side.

You will find additional storage compartments in all of the doors as well as on the backrests of the front seats.

Cellular phone*



Handsfree system

On vehicles with a telephone hookup*, the handsfree speaker is positioned in the headliner.

For further information on the cellular phone, refer to the separate Owner's Manual.

Beverage holder*



Two holders for canned drinks have been provided in the front center console (illustration).

Press to open; fold back inward to close.

126 Ashtray, front

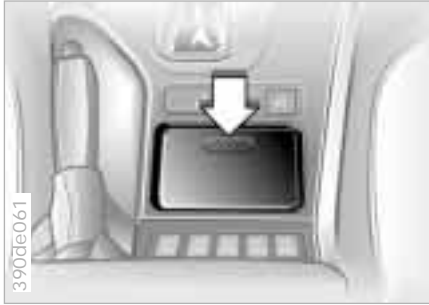

To open

Press briefly in the direction indicated by the arrow.

To extinguish a cigarette, tap off the ash and gently press the tip into the funnel.



To empty

Open the lid and press down (arrow): You can now pull the ashtray upward for removal.

On vehicles equipped for non-smokers, the insert is removed in the same way.

Cigarette lighter*



Press the cover panel for access (arrow), then push the lighter down.

As soon as the lighter jumps back out, it can be removed

 Hold or touch the hot cigarette lighter by the knob only. Holding or touching it in other areas could result in burns.

The cigarette lighter remains operational when the ignition key has been removed. Therefore, do not leave unsupervised children in the vehicle. ◀

Cigarette lighter*

Cigarette lighter socket

Suitable for attaching power supplies for flashlights, car vacuum cleaners, etc., up to a rating of approx. 200 watts at 12 volts. Avoid damage to the socket caused by inserting plugs of different shapes or sizes.

Non-smoker's equipment package

On vehicles with the non-smoker's equipment package, the socket is concealed by a cover.

For access to the socket: lift off the cover.

Ashtray, rear



To open

Press the recess in the lid.

To empty

Press the edge of the cover (arrow).
You can now pull the ashtray upward for removal.

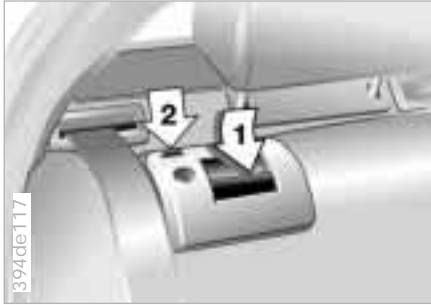

The backrest of the rear seat is divided into two portions, one-third and two-thirds of the seat respectively. For storing longer objects, you can fold down either side individually.

To open:

Reach into the recess and pull forward (arrow 1).

When you close the backrest, be sure that the catch engages securely. The red slide (arrow 2) must go underneath.



The central belt has an additional small buckle.

- ▷ If you connect the two belt sections, you can use the central belt as any normal 3-point belt.
- ▷ It is easier to fold the rear seat backrest up and down if you unbuckle the belt (arrow).



With a master key, you can lock each backrest in the rear seat.

This also prevents access to the luggage compartment from the interior of the vehicle when you turn over the door and ignition key 3 to someone else (refer to page 36), for valet parking for instance.

Ski bag*

Designed for safe, convenient transport of up to 4 pairs of standard skis or up to 2 snowboards.

The length of the ski bag and the additional space provided in the luggage compartment make it possible to carry skis with a length of up to 6.8 ft (2.10 meters). Because of the tapered shape of the bag, the ski bag can only accommodate two pairs of skis with a length of 6.8 ft (2.10 meters).



Installing the center armrest

Guide the armrest into position from above, then apply pressure until you hear it snap into position.

 When removing and installing the center armrest, be sure that the seat covers are not damaged by the side pins. ◀

Removing the center armrest

(Not for vehicles with the through-loading system and for the sport wagon. Refer to page [131](#).)

- 1 Fold the center armrest completely outward.
- 2 Loosen the trim from the upper Velcro® fastener and place it on the armrest.
- 3 Grasp the front of the armrest with one hand, then use your other hand to reach down behind the armrest and pull up sharply (arrow).



Loading

- 1 Press the release button (arrow 1) to unlock the cover panel in the luggage compartment.
- 2 Press the detent levers (arrows 2) inward and fold the cover to the front.
- 3 Extend the ski bag between the front seats. The zipper provides convenient access to the inside of the bag, and can also be left open to promote drying.

- 4 Use the magnetic retainers to attach the cover panel to the upper surface (metal surface below rear tray) of the luggage compartment.

To store the ski bag, perform the above steps in reverse sequence.



An unsecured ski bag could lead to loss of vehicle control and in case of an accident to personal injury. ◀



Secure the bag's contents by tightening down the attached strap at the buckle. ◀

Please ensure that the skis are clean before loading them into the bag. Take care to avoid damage from sharp edges.



With through-loading system

- 1 Fold the center armrest outward. Loosen the trim from the upper Velcro® fastener and place it on the armrest.
- 2 Press button 1 downward and swing the cover forward.
- 3 Press knob 2: the cover in the luggage compartment is unlocked.



In the sport wagon

- 1 Fold the center armrest outward. Loosen the trim from the upper Velcro® fastener and place it on the armrest.
- 2 Press button 1 downward and swing the cover forward.
- 3 Press button 2: the cover in the luggage compartment is unlocked.



Fold down the rear backrests

Reach into the recess and pull upward (arrow).

The rear backrest is divided into two sections, one-third and two-thirds of the seat respectively. You can fold either section of the backrest down separately in order to increase luggage compartment capacity.



When you close the backrest, be sure that the catch engages securely. The red warning indicator disappears in the recess when the retainer is locked.

The center safety belt can be retracted only when the larger backrest is engaged. ◀



Roll-up cover

Pull the roll-up cover out and hook it into the rear bracket.

The cover will support light objects such as items of clothing.



Do not place heavy or bulky objects on the roll-up cover, otherwise, they could endanger occupants while braking hard, during evasive maneuvers, or in an accident, for example.

Do not allow the cover to snap back, since this could damage it. ◀

For storing the case, refer to the next page.



Partition net

Pull out the partition net by the strap and hold the bar firmly in the other hand. Then grasp the bar on both sides, pull it up and engage it in the holders. It is easiest to do this from the back seat.



Do not allow the partition net to snap back. Doing so could pose a risk of injury and the partition net could be damaged. ◀

When the rear backrests are folded down, you can store the case in front of the rear seats, pull the partition net out from there and insert it in the front holders (refer to the next page).

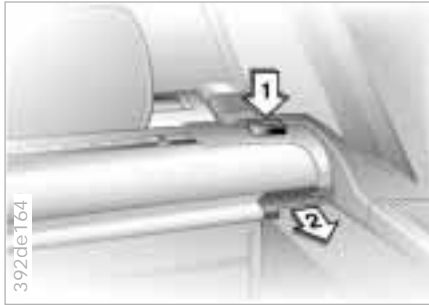

Removing the roll-up cover and partition net

- 1 Press on the buttons (arrow 1) to release the case on both sides.
- 2 Holding the case straight, pull out to the rear (arrow 2).

Installation

Simply slide the case forward in the two side holders until it engages.



Storage

There are holders for the case in front of the rear seats.

Guide the case in from the side as shown in the illustration. The strap of the partition net must be directed upward, while the end of the roll-up cover must be laid around and under the case to the rear.

You can pull the partition net out and insert it in the holders above it in the upper roof area.

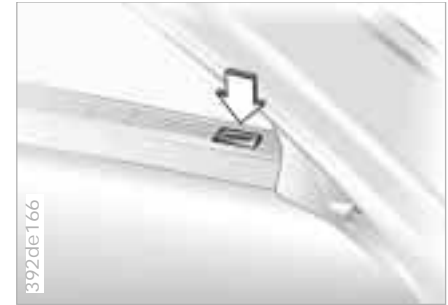

Side covers

Open the side covers by pressing the button.

134 Luggage compartment – sport wagon



Floor compartment

To open: press the handle in the recess and fold the cover upward on the handle (large arrow).

You can lock the cover with a master key.

The dividers in the compartment can be rearranged. If you remove the divider and turn the divider retainer to the left and remove it, you have a level storage compartment.



Fold up the floor panel

Lift up the black retainer on the lower side of the panel and hook it into the upper frame of the tailgate cutout.

Before you fold the floor panel down, return the retainer to its original position.

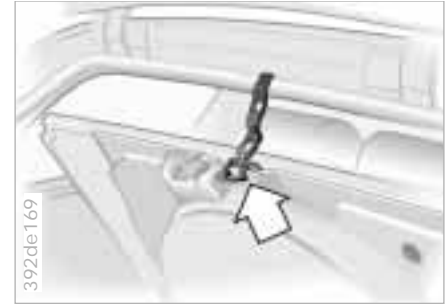

Fold up the spare tire cover

Lift up the cover and hook it into the red retainer on the floor panel (arrow).

Before you fold the cover down, return the retainer to its original position.



Raise the cargo floor

For access to the compartment under the floor or to the spare tire, etc.:

- ▷ Raise the cargo floor and secure it with the support rod (arrow).
- ▷ Open the quick-release fasteners on the spare tire cover.

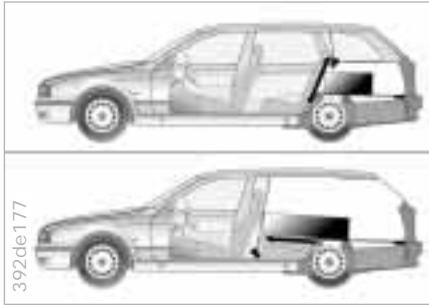

Stowing cargo

When transporting loads in your BMW:

- ▷ Position heavy loads as far forward as possible – directly behind the backrests or the luggage compartment partition panel – and at the bottom (the illustration shows the sport wagon).
- ▷ Cover sharp edges and corners
- ▷ Do not pile objects higher than the top edge of the backrest.
- ▷ Pull out the partition net* (refer to page 132) and ensure that carried items cannot pass through the partition net.
- ▷ For very heavy loads when the rear seat is not occupied, secure each safety belt in the opposite buckle.

Securing the load

- ▷ Secure smaller, light pieces with the retaining straps or a luggage net*, or use elastic straps (refer to page 46).
- ▷ For large, heavy pieces, visit your BMW center for load-securing devices*. Lashing eyes are provided at the corners of the luggage compartment for attaching these load-securing devices (the illustration shows the sport wagon).
- ▷ Comply with the information enclosed with the load-securing devices.



Always position and secure the load correctly, otherwise it can endanger the passengers during braking or evasive maneuvers.

Do not exceed the permissible gross vehicle weight and the permissible axle loads (refer to page 221). If you do, the operating safety of the vehicle is no longer ensured and you are in violation of the law.

Do not carry hard or heavy objects unsecured in the passenger compartment. If you do so, they may be projected through the air during braking and evasive maneuvers, thus endangering vehicle occupants. ◀

Roof-mounted luggage rack



Mounting points

Access to the mounting points:
To fold up the cover (arrow), please use the tool which is provided with the luggage system.

A special luggage system is available as an option for your BMW. Please comply with the precautions included with the installation instructions.

Because roof racks raise the center of gravity of the car when loaded, they exercise a major effect on its handling and steering response.

You should therefore always remember not to exceed the approved roof weight, the approved gross vehicle weight or the axle weights when loading the rack. You will find the specifications under "Technical data" on page [221](#).

Make sure that the load is not too bulky, and attempt to distribute it evenly. Always load the heaviest pieces first (on the bottom). Be sure that adequate clearance is maintained for raising the sliding/tilt sunroof, and that objects do not project into the opening path of the luggage compartment lid/tailgate.

Secure the roof luggage correctly and tightly to prevent it from shifting or being lost during driving (danger to following traffic).

Drive smoothly. Avoid sudden acceleration and braking maneuvers. Take corners gently.

The roof load increases aerodynamic resistance: increased fuel consumption and stress on the roof are the immediate results.



Special operating instructions:

- Break-in procedure [140](#)
- Driving notes [141](#)
- Catalytic converter [142](#)
- Antilock Brake System (ABS) [143](#)
- Disc brakes [144](#)
- Brake system [146](#)
- Winter operation [146](#)
- Power steering [148](#)
- Level control system [148](#)
- Cellular phone [149](#)
- Radio reception [149](#)

Wheels and tires:

- Tire inflation pressure [150](#)
- Tire condition [150](#)
- Tire replacement [151](#)
- Tire rotation [152](#)
- Wheel and tire combinations [153](#)
- Winter tires [154](#)
- Snow chains [155](#)
- Approved wheel and tire specifications [156](#)

Under the hood:

- Hood [159](#)
- Engine compartment [160](#)
- Washer fluids [164](#)
- Washer nozzles [164](#)
- Engine oil [165](#)
- Coolant [167](#)
- Brake fluid [168](#)
- Vehicle Identification Number [169](#)

Care and maintenance:

- The BMW Maintenance System [170](#)
- Caring for your car [171](#)
- Airbags [176](#)
- Vehicle storage [176](#)

Laws and regulations:

- Technical modifications [177](#)
- California Proposition 65 Warning [177](#)
- OBD interface socket [178](#)

Overview**Controls and features****Operation, care and maintenance****Owner service procedures****Advanced technology****Technical data****Index**

To ensure that your vehicle provides maximum economy throughout a long service life, we request that you observe the following.

Engine and differential

Up to 1,200 miles (2,000 km):

Drive at varying engine speeds and road speeds, but do not exceed 4,500 rpm and the following road speeds during this initial period:

BMW 525i, 530i: 100 mph (160 km/h)

BMW 540i: 106 mph (170 km/h)

Obey your local and state maximum speed limits.

Refrain from using full throttle and avoid pressing the accelerator beyond the kickdown point.

Once you have driven 1,200 miles (2,000 km), engine and vehicle speeds can gradually be increased.

You should also comply with these break-in procedures if the engine or differential is replaced later in the course of the vehicle service life.

Tires

Due to technical factors associated with their manufacture, tires do not achieve their full traction potential until an initial break-in period has elapsed for this reason, drive with extra care during the initial 200 miles (300 km).

Obey your local and state maximum speed limits.



When the vehicle is operated on wet or slushy roads, a wedge of water may form between the tire and the road surface. This phenomenon is referred to as aquaplaning, or hydroplaning, and can lead to partial or complete loss of traction, vehicle control and braking effectiveness. Reduce your speed on wet roads. ◀

Brake system

Approximately 300 miles (500 km) must elapse before the brake pads and rotors achieve the optimal pad-surface and wear patterns required for trouble-free operation and long service life later on.

To break in the separate parking brake drums, apply the parking brake lightly when coasting to a standstill (at a traffic signal, for instance), provided that traffic conditions allow you to do so. To avoid corrosion, repeat this procedure from time to time.



The brake lamps do not come on when the parking brake is applied. Vacuum for the brake system servo unit on your BMW is available only when the engine is running. When you move the car with the engine shut off – when towing, for instance – substantially higher levels of pedal force will be required to brake the vehicle. ◀

Clutch

The clutch will also begin to function optimally after about 300 miles (500 km). Engage the gears carefully during the break-in period.

Driving notes



Brakes:

Do not drive with your foot resting on the brake pedal. Even light but consistent pedal pressure can lead to high temperatures, brake wear and possibly even brake failure.

Aquaplaning:

When driving on wet or slushy roads, reduce road speed. If you do not, a wedge of water can form between tires and road surface. This phenomenon is referred to as aquaplaning or hydroplaning. It is characterized by a partial or complete loss of contact between the tires and the road surface. The ultimate results are loss of steering and braking control.

Driving through water:

Do not drive through water more than 1 ft (30 cm) deep. Drive only at walking speed. Driving at a faster speed could cause damage to the engine, the electrical system and the transmission.

Rear parcel tray:

Do not use the rear parcel tray to store heavy or bulky objects. They could pose a danger to the occupants during braking, evasive maneuvers, or in an accident.

Clothes hooks:

Hang items of clothing from the hooks so that they will not obstruct the driver's vision. Do not hang any heavy objects on the hooks, as otherwise passengers could be injured, e.g. during any hard braking or evasive maneuvers, or during an accident. ◀

142 Catalytic converter

The catalytic converter reduces harmful exhaust emissions, and is designed for use with unleaded fuel only.

Even minute quantities of lead would be enough to permanently damage both the catalytic converter and the system oxygen sensor.

To ensure efficient, trouble-free engine operation and avoid potential damage:

- ▷ Be sure to comply with the scheduled maintenance requirements.
- ▷ Fill the fuel tank well before it is empty.
- ▷ Tow-start the vehicle only when the engine is cold, since unburned fuel may otherwise reach the catalytic converter. It is better to start the vehicle with an outside starting aid.

- ▷ Avoid other situations in which the fuel is not burned, or burns incompletely, such as engaging the starter frequently or for extended periods, or repeated start attempts in which the engine does not start (stopping and restarting an engine which is running properly does not present a problem). Never let the engine run with any of the spark plug cables disconnected.



Be sure to comply with the instructions above to prevent unburned fuel from reaching the catalytic converter. Otherwise there is danger of overheating and damage to the catalytic converter.

Extreme temperatures occur at the catalytic converter on this and every catalyst-equipped vehicle. Heat shields are installed adjacent to some sections of the exhaust system. Never remove these shields; do not apply undercoating to their surfaces. When driving, standing at idle, and parking the vehicle, take care to avoid contact between the exhaust system and flammable materials (grass, hay, leaves, etc.). Such contact could lead to a fire, resulting in personal injury and property damage. ◀

Antilock Brake System (ABS)

The concept

ABS enhances active safety by helping to prevent the wheels from locking under braking. The reason: locked wheels are dangerous, because the vehicle cannot be steered when the front wheels slip, and loss of traction at the rear wheels can cause the rear end to break into an uncontrolled skid.

ABS is designed to meet two essential requirements during every brake application:

- ▷ To help provide vehicle stability.
- ▷ To help retain steering and maneuvering capability on all types of road surface (asphalt, concrete, dirt, moisture, snow and ice).

With ABS, the shortest possible braking distances are achieved under most conditions (on straight-aways and in curves, with different road surfaces).

Braking with ABS

The system becomes operative once the vehicle exceeds a speed of approx. 6 mph (10 km/h). The ABS is deactivated whenever the vehicle's speed drops back below approx. 4 mph (6 km/h). This means that the wheels can lock in the final phase of a brake application – a factor of no significance in actual use.

The ABS system works best in situations requiring maximum pressure on the pedal (full braking). Since the vehicle maintains steering responsiveness, you can nevertheless avoid possible obstacles with a minimum of steering effort.

The ABS closed-loop control circuit cycles in fractions of a second. A pulsing of the brake pedal, combined with the sounds associated with the hydraulic controls, tells you that the brake system is within its maximum limit range and reminds you that you should adapt your vehicle's speed to road conditions.

On road surfaces which have a loose layer on a firm base (on gravel or snow, for instance), the braking distances with ABS may be longer than with the wheels locked. This also applies to driving with snow chains. However, ABS continues to provide enhanced vehicle stability and steering response under these conditions.

Information for your safety

Not even ABS can suspend the laws of physics. The consequences of brake applications with inadequate safety clearances between vehicles, excessive speed or if aquaplaning occurs are always the responsibility of the driver. You should never allow the added safety margin of ABS to mislead you into taking risks of any kind.



Do not make any modifications to the ABS system.

Service procedures on ABS are to be performed by authorized technicians only. ◀

In the event of a fault

The ABS warning lamp in the instrument cluster comes on, refer to page 23. The brake system then reverts to conventional operation as on vehicles without ABS. However, have the brake system checked by your BMW center as soon as possible. To prevent undetected defects and cumulative faults from adversely affecting the brake system, refer any problems to your BMW center at the earliest opportunity.

**Disc brakes**

Disc brakes furnish optimum deceleration and braking control and greater fade resistance under heavy use.

When the vehicle is driven only occasionally, during extended periods when the vehicle is not used at all, and in operating conditions where brake applications are less frequent, there is an increased tendency for corrosion of the rotors and accumulation of contamination on the brake pads. This occurs because the minimal pressure which must be exerted by the pads during brake applications to clean the rotors is not reached.

If the brake rotors are corroded, they will tend to respond to braking with a pulsating effect which even extended application will fail to cure.



For your own safety: use only brake pads that BMW has approved for your specific vehicle model. BMW cannot evaluate non-approved brake pads to determine if they are suited for use, and therefore cannot ensure the operating safety of the vehicle if they are installed. ◀

Disc brakes

Driving notes

When driving in wet conditions and in heavy rain, it is effective to apply light pressure to the brake pedal every few miles (kilometers). Watch traffic conditions to ensure that this maneuver does not endanger other road users. The heat which is generated by the brake applications helps to dry the brake pads and rotors.

Maximum braking force is obtained while the wheels continue to rotate, peaking when the wheels remain on the verge of locking without actually doing so. ABS maintains this state automatically. If the ABS fails, you should revert to the staggered braking technique described below (refer to page 147).

Extended or steep mountain descents should be driven in the gear in which only minimal periodic brake applications is required. This avoids excessive strain on the brakes and possible impairment of the braking effect.

The braking effect of the engine can be further increased by downshifting, into first gear, if necessary. In the manual mode of the automatic transmission, you can also downshift into first gear. Refer to page 76.

Should engine braking prove inadequate, you should still avoid extended, continuous braking. Instead of maintaining low to moderate pressure over an extended period of time, you should decelerate by applying more substantial pressure to the brake pedal (watch for following traffic!), then releasing the pedal, then repeating the application. This staggered braking technique allows the brakes to cool in the intervals between active braking phases, preventing overheating and ensuring that full braking capacity remains available at all times.



Do not coast with the clutch depressed or with the transmission or selector lever in Neutral. Do not coast with the engine shut off. The engine provides no braking effect when the clutch is depressed or the transmission is in neutral, and there is no power-assist for braking or steering when the engine is not running. Never allow floor mats, carpets or any other objects to protrude into the area around the accelerator, clutch and brake pedals and obstruct their movement. ◀

Dynamic Brake Control (DBC)*

If you apply the brakes rapidly, this system automatically produces the maximum braking force boost and thus helps to achieve the shortest possible braking distance during "panic stops." All of the benefits of the ABS system are exploited under these circumstances.

Do not reduce the pressure on the brake pedal for the duration of the brake application. When the brake pedal is released, the DBC is deactivated.

In the event of a malfunction, the yellow warning lamp comes on. Conventional braking efficiency is available without limitations.

Have the system checked and repaired at your BMW center as soon as possible.



For "Information for your safety" covering the ABS system, refer to page 144. This information also generally applies for DBC. ◀

Brake fluid level

The warning lamp for the brake hydraulic system comes on, or the "CHECK BRAKE FLUID" message appears in the Check Control.



The brake fluid level is too low in the reservoir (refer to page 168).

If the brake fluid level is too low and brake pedal travel has become noticeably longer, there may be a defect in one of the brake system's hydraulic circuits.



Proceed to the nearest BMW center. Higher brake application pressure may be necessary under these conditions, and brake pedal travel may be significantly longer. Please remember to adapt your driving style accordingly. ◀

The warning lamp comes on together with the "CHECK BRAKE PADS" message in the Check Control.

Brake pads

The warning lamp for the brake pads comes on, or the "CHECK BRAKE LININGS" message appears in the Check Control:

The brake pads have reached their minimum pad thickness. Proceed to the nearest BMW center as soon as possible to have the pads replaced.



For your own safety: use only brake pads that BMW has approved for your specific vehicle model. BMW cannot evaluate non-approved brake pads to determine if they are suited for use, and therefore cannot ensure the operating safety of the vehicle if they are installed. ◀

Winter operation

The onset of winter is often accompanied by rapid changes in weather. Adaptations in driving style should be accompanied by preparations on the vehicle itself to ensure that your vehicle operation through the winter remains safe and trouble-free.

Coolant

Ensure that the coolant mixture contains the year-round ratio of 50:50 of water and antifreeze/corrosion inhibitor. This mixture provides protection against freezing down to approx. -34 °F (-37 °C). Replace the coolant every four years.

Locks

BMW door lock deicer can be used to free the locks if they are frozen. This deicer also contains lubricant. After using deicer, treatment with BMW lock barrel grease is recommended.

Winter operation

Rubber seals and components

In order to prevent the weather-stripping from freezing, apply BMW rubber treatment or silicone spray to the seals on the doors, hood and luggage compartment lid/tailgate.



A full range of car-care products is available from your BMW center. ◀

Snow chains

BMW snow chains* can be mounted on both summer and winter tires. Mount them in pairs on the rear wheels only and comply with the manufacturer's safety precautions. Do not exceed a maximum speed of 30 mph (50 km/h). For maximum traction, we recommend that you manually deactivate the ASC+T/DSC* when driving with snow chains mounted. Refer to page 102.

Starting off

We recommend that you use the manual control switch to deactivate ASC+T/ DSC* when starting off in deep snow or when rocking the car to free it (refer to page 102).

Driving on low-traction road surfaces

Use smooth, gentle pressure to control the accelerator pedal. Avoid excessive engine speeds and shift to the next higher gear at an early point. Adapt your speed and driving style when approaching grades or slopes. Maintain an adequate distance between yourself and the vehicle ahead.

Brakes

Winter road conditions substantially reduce the amount of traction available between the tires and the road surface. The resulting increases in braking distance are considerable and should be kept in mind at all times.

ABS is intended to prevent the wheels from locking during brake applications, thus helping to maintain vehicle stability and steering response.

If the ABS does not respond in a critical braking situation and the wheels lock: reduce the pressure on the brake pedal until the wheels just start to roll again while still maintaining enough force to continue braking.

Following that, increase pedal pressure again. Reduce the pressure as the wheels lock, then reapply pressure. Repeat this procedure.

This type of staggered braking will reduce the braking distance, and the vehicle still remains responsive to steering.

You can then attempt to steer around hazards after you have reduced pressure on the brake pedal.



Do not shift down on slick road surfaces. Doing so could cause the rear wheels to lose traction and skid, which could result in the loss of vehicle control. ◀



Depress the clutch during hard braking on road surfaces which provide only poor or uneven traction. ◀

Skid control

Release the accelerator pedal and depress the clutch pedal. Countersteer carefully and attempt to regain control of the vehicle.

Parking

Engage 1st or reverse gear. If your vehicle is equipped with an automatic transmission, place the selector lever in "Park." On vehicles with manual transmission, also apply the parking brake when parking on inclined surfaces. In order to prevent the parking brake pads from locking due to frost or corrosion, dry them by gently applying the parking brake as the vehicle is coming to a stop. Make sure that following traffic is not endangered.



The brake lamps do not come on when the parking brake is applied. ◀

Power steering

If there is a change in steering behavior, for instance greater steering effort or if steering becomes lighter as speed increases in vehicles equipped with Servotronic*: Contact your BMW center for an inspection.



If the power steering fails, increased effort will be required to steer the vehicle. ◀

Level control system*

The warning lamp for the level control system comes on, or the message "LEVEL CONTROL INACTIVE" appears in the Check Control*: there is a malfunction in the level control system.

Stop and inspect the vehicle. If it is riding significantly lower in the rear than in the front, or if it is sitting at an incline (left rear compared to right rear), consult the nearest authorized BMW center. Drive with appropriate caution in the meantime. The vehicle has reduced ground clearance or driving comfort is noticeably reduced.

Even if the attitude of the vehicle is normal, you should consult the nearest BMW center if the warning lamp indicates a system fault.

Cellular phone*

Mobile communications systems (cellular phone, radio, etc.) are permitted with an output of up to 10 watts only. Even these systems may trigger malfunctions in the operation of your vehicle if they are not specifically designed for use with the vehicle. BMW can neither test nor assume responsibility for every individual product being offered on the market. We recommend that you consult your BMW center before purchasing any device of this kind.

To ensure that your BMW continues to provide reliable and trouble-free operation, do not use a cellular phone or other radio device with an antenna located inside the passenger compartment. The antenna should always be mounted on the outside of the vehicle.



Before loading the vehicle on a car-carrier train or driving it through a car wash, remove the antenna. ◀

Radio reception

The reception and sound quality obtained from mobile radios varies according to a variety of factors, including the broadcast range of the transmitter and the directional orientation of the antenna. Interference factors such as high-tension power lines, buildings and natural obstructions can all lead to unavoidable reception interference, regardless of how well the vehicle sound system is operating. Climatic factors such as intense solar radiation, fog, rain and snow can also interfere with reception.

Cellular phones without official BMW approval can also generate interference. This phenomenon assumes the form of a low-pitched hum emanating from the speaker system.

Please refer to the Owner's Manual provided with your audio system for detailed information on its use.

Information for your safety

The factory-approved radial tires are matched to the car and have been selected to provide optimum safety and driving comfort on your vehicle.

It is not merely the tire's service life, but also driving comfort and – above all else – driving safety which depend on the condition of the tires and the maintenance of the specified tire pressure.

Incorrect inflation pressure is a frequent cause of tire damage. It also significantly influences the roadholding ability of your BMW.

 Check tire inflation pressures – including the spare tire – regularly (refer to page 29), at least every two weeks and before beginning a longer trip. If this is not done, incorrect tire pressures can cause driving instability and tire damage, ultimately resulting in accidents. ◀

**Tire tread – tire damage**

Inspect your tires frequently for tread wear, signs of damage and for foreign objects lodged in the tread. Check the tread depth.

Tread depth should not be allowed to go below 0.12 in (3 mm), even though the legally specified minimum tread depth is only 0.063 in (1.6 mm). At a tread depth of 0.063 in (1.6 mm), tread depth indicators (arrow) in the tread-groove base indicate that the legally permissible wear limit has been reached. Below 0.12 in (3 mm) tread depth, there is an increased risk of aquaplaning, even at relatively moderate speeds and with only small amounts of water on the road.

 Do not drive on a deflated (flat) tire. A flat tire greatly impairs steering and braking response, and can lead to complete loss of control over the vehicle.

Avoid overloading the vehicle so that the permitted load on the tires is not exceeded. Overloading can lead to overheating and increases the rate at which damage develops inside the tires. The ultimate result can assume the form of a sudden air loss.

Unusual vibrations encountered during normal vehicle operation can indicate tire failure or some other vehicle defect, as can variations in normal vehicle response, such as a pronounced tendency to pull to the left or right. Should this occur, respond by immediately reducing your speed and carefully proceeding to the nearest BMW center or professional tire center, or having the vehicle towed in to have it and its tires inspected.

Tire damage (up to and including blow-outs) can endanger the lives of both the vehicle occupants and other road users. ◀

Tire replacement

To maintain good handling and vehicle response, use only tires of a single tread configuration from a single manufacturer. BMW tests and approves wheel/tire combinations. Refer to page [153](#).

DOT Quality Grades

Treadwear

Traction AA A B C

Temperature A B C



All passenger car tires must conform to Federal Safety Requirements in addition to these grades. ◀

Treadwear

The treadwear grade is a comparative rating based on the wear rate of the tire when tested under controlled conditions on a specified government test course.

For example, a tire graded 150 would wear one and one-half (1 ½) times as well on the government course as a tire graded 100. The relative performance of tires depends upon the actual conditions of their use, however, and may depart significantly from the norm due to variations in driving habits, service practices and differences in road characteristics and climate.

Traction

The traction grades, from highest to lowest, are AA, A, B and C. Those grades represent the tire's ability to stop on wet pavement as measured under controlled conditions on specified government test surfaces of asphalt and concrete. A tire marked C may have poor traction performance.



The traction grade assigned to this tire is based on straight-ahead braking traction tests, and does not include acceleration, cornering, hydroplaning, or peak traction characteristics. ◀

Temperature

The temperature grades are A (the highest), B and C, representing the tire's resistance to the generation of heat and its ability to dissipate heat when tested under controlled conditions on a specified indoor laboratory test wheel. Sustained high temperature can cause the material of the tire to degenerate and reduce tire life, and excessive temperature can lead to sudden tire failure. The grade C corresponds to a level of performance which all passenger car tires must meet under the Federal Motor Vehicle Safety Standard No. 109. Grades B and A represent higher levels of performance on the laboratory test wheel than the minimum required by law.



The temperature grade for this tire is established for a tire that is properly inflated and not overloaded. Excessive speed, underinflation, or excessive loading, either separately or in combination, can cause heat buildup and possible tire failure. ◀

Uniform Tire Quality Grading

Quality grades can be found where applicable on the tire sidewall between tread shoulder and maximum section width. For example:

Treadwear 200 Traction AA
Temperature A



Do not use retreaded tires, since driving safety may be impaired. This is due to the possible variations in casing structures and, in some cases, to their extreme age, which can lead to a decrease in their durability. ◀

Tire age

The date on which the tire was manufactured is indicated by the code on the sidewall:

DOT ... 2600 indicates that the tire was manufactured in Week 26 of 2000.

BMW recommends the replacement of all tires when the tires are no more than 6 years old, even if a tire life of 10 years is possible.

Spare tires over 6 years old should be used only in case of emergency. Such a tire should be replaced by a new tire immediately, and should not be mounted together with new tires.

Tire rotation

Between the axles

The tread wear patterns at the front end differ from those at the rear – the actual patterns will vary according to individual driving conditions. In the interests of safety and maintaining optimal handling characteristics, interaxle tire rotation is not recommended.

If a proposed interaxle rotation of tires is based on economic considerations, one should consider whether the costs for the rotation are likely to be recaptured by any increase in the service life of the tires which might be realized. In principle, interaxle tire rotation should be performed at short intervals, with a maximum of 3,000 miles (5,000 km). Consult your BMW center for more information.

Tire rotation

Should you decide to rotate the tires, it is essential to comply with the following: rotate tires on the same side only, since braking characteristics and road grip could otherwise be adversely affected.

Following tire rotation, correct the tire inflation pressure.

 If different tire sizes are mounted on the front and rear axles (refer to page 156), the wheels may not be rotated from one axle to the other. ◀

Wheel and tire combinations

The right choice

Use only tires approved by BMW. Refer to the information beginning on page 156.

Because of the high speeds this vehicle can reach, the use of specific tire brands, specifications and dimensions is mandatory. Consult any BMW center for details.

Comply with national, state, or province regulations.

 The correct wheel-tire combination affects different systems such as ABS, ATC, ASC+T/DSC. The function of these systems is impaired if improper wheel-tire combinations are used.

For this reason, use only tires of the same brand and tread pattern. In the event of a flat tire if you have mounted winter tires, for example, remount the approved wheel-tire combination as soon as possible. ◀

Codes on tires and wheels

The tire codes will aid you in selecting the correct tire.

Codes on radial tires:

Example: 235/60 R 16 100W

Nominal width in mm _____

Aspect ratio in % _____

Radial tire code _____

Rim diameter in inches _____

Load rating (not on ZR tires) _____

Speed rating (before R on ZR tires) _____

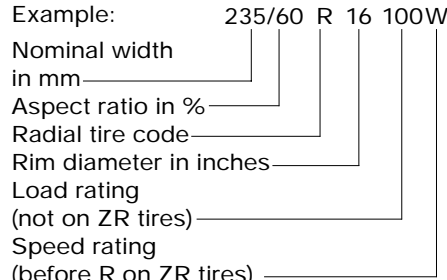

The speed rating indicates the approved maximum speed for the tire.

Summer tires:

S = up to 112 mph (180 km/h)
 T = up to 118 mph (190 km/h)
 H = up to 130 mph (210 km/h)
 V = up to 150 mph (240 km/h)
 W = up to 167 mph (270 km/h)
 Y = up to 186 mph (300 km/h)
 ZR= over 150 mph (240 km/h)

With all-season and winter tires:

Q M+S = up to 100 mph (160 km/h)

T M+S = up to 118 mph (190 km/h)

H M+S = up to 130 mph (210 km/h)

Codes stamped on light-alloy wheels:

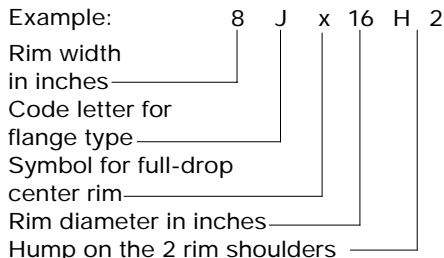

Protect valve inserts against dirt using screw-on valve stem caps. Dirt in the valves frequently leads to slow leaks.

Winter tires

Choosing the right tire

BMW recommends winter tires (M+S radial tires) for driving in adverse winter road conditions. While tires known as all-season tires (M+S designation) provide better winter traction than summer tires with load ratings H, V, W, Y and ZR, they generally do not achieve the performance of winter tires.

In the interests of safe tracking and steering response, install radial tires made by the same manufacturer and with the same tread configuration on all four wheels if you elect to mount winter tires.

Mount only winter tires which have been approved by BMW. Any BMW center will be glad to provide you with information for selecting the best winter tires for your particular driving conditions.

Do not exceed specified maximum speeds



Never exceed the maximum speed for which the tires are rated.

Unprofessional attempts by laymen to service tires can lead to damage and accidents.

Have this work performed by skilled professionals only. Any BMW center has the required technical knowledge and the proper equipment and will be happy to assist you. ◀

Tire condition, tire pressure

Winter tires display a perceptible loss in their ability to cope with winter driving conditions once the tread wears to below 0.16 in (4 mm), and should thus be replaced.

Comply with the specified tire inflation pressures – and be sure to have the wheel and tire assemblies balanced every time you change the tires.

Storage

Store tires in a cool, dry place, away from light whenever possible. Protect the tires against contact with oil, grease and fuel.

Use narrow-link BMW snow chains on summer or winter tires only in pairs and only on the rear wheels. Comply with all manufacturer's safety precautions when mounting the chains.



It is not possible to mount snow chains on tires with 17-inch wheels. ◀

156 Approved wheel and tire specifications – sedan

Tire specifications	Steel rim (wheel rim)	Light-alloy wheel
BMW 525i		
All season tires		
225/60 R 15 96 H M+S	–	7Jx15
225/55 R 16 95 H M+S	–	7Jx16
Summer tires		
225/60 R 15 96 W	–	7Jx15
225/55 R 16 95 W	–	7Jx16
235/45 R 17 94 W/Y	–	8Jx17
Front: 235/45 R 17 94 W/Y	–	8Jx17
Rear: 255/40 R 17 94 W/Y	–	9Jx17
Winter tires (M+S)		
205/65 R 15 94 Q	6.5Jx15	6.5Jx15
	7Jx15	7Jx15
225/60 R 15 96 Q	7Jx15	7Jx15
225/55 R 16 95 Q	–	7Jx16
235/45 R 17 94 Q	–	8Jx16

Pay attention to the specifications for tires and wheels in the vehicle's documents. If sizes not approved by the manufacturer are mounted, an entry in the vehicle's documents may be necessary. Comply with local legislation.



The use of rims and wheel bolts that do not meet the specifications of the original factory-installed equipment will affect the safe operation of your vehicle and may cause an accident and personal injury. Never mix tires of different design, such as steel-belted radials with radial bias-belted or bias-ply tires, etc. Mixing tire types will adversely affect roadholding and can lead to loss of vehicle control. ◀

Tire specifications	Steel rim (wheel rim)	Light-alloy wheel
BMW 530i, 540i:		
All season tires (BMW 530i, 540iA only)		
225/55 R 16 95 H M+S	-	7Jx16
Summer tires		
225/55 R 16 95 W	-	7Jx16
235/45 R 17 94 W/Y	-	8Jx17
Front: 235/45 R 17 94 W/Y	-	8Jx17
Rear: 255/40 R 17 94 W/Y	-	9Jx17
Winter tires (M+S)		
225/55 R 16 95 Q/T/H	-	7Jx16
235/45 R 17 94 Q/T/H	-	8Jx17

Pay attention to the specifications for tires and wheels in the vehicle's documents. If sizes not approved by the manufacturer are mounted, an entry in the vehicle's documents may be necessary. Comply with local legislation.

Snow chains*

For tires on 17-inch wheels, it is not possible to mount snow chains.



The use of rims and wheel bolts that do not meet the specifications of the original factory-installed equipment will affect the safe operation of your vehicle and may cause an accident and personal injury. Never mix tires of different design, such as steel-belted radials with radial bias-belted or bias-ply tires, etc. Mixing tire types will adversely affect roadholding and can lead to loss of vehicle control. ◀

158 Approved wheel and tire specifications – sport wagon

Tire specifications	Steel rim (wheel rim)	Light-alloy wheel
BMW 525i		
All season tires		
225/60 R 15 96 H M+S	–	7Jx15
225/55 R 16 95 H M+S	–	7Jx16
Summer tires		
225/60 R 15 96 W	–	7Jx15
225/55 R 16 95 W	–	7Jx16
235/45 R 17 94 W/Y	–	8Jx17
Winter tires (M+S)		
225/60 R 15 96 Q	7Jx15	7Jx15
225/55 R 16 95 Q	–	7Jx16
235/45 R 17 94 Q	–	8Jx17
BMW 540i		
All season tires		
225/55 R 16 95 H M+S	–	7Jx16
Summer tires		
225/55 R 16 95 W	–	7Jx16
235/45 R 17 94 W/Y	–	8Jx17
Winter tires (M+S)		
225/55 R 16 95 Q	–	7Jx16
235/45 R 17 94 Q	–	8Jx17

Pay attention to the specifications for tires and wheels in the vehicle's documents. If sizes not approved by the manufacturer are mounted, an entry in the vehicle's documents may be necessary. Comply with local legislation.

Snow chains*

For tires on 17-inch wheels, it is not possible to mount snow chains.



The use of rims and wheel bolts that do not meet the specifications of the original factory-installed equipment will affect the safe operation of your vehicle and may cause an accident and personal injury.

Never mix tires of different design, such as steel-belted radials with radial bias-belted or bias-ply tires, etc. Mixing tire types will adversely affect roadholding and can lead to loss of vehicle control. ◀



To unlock

Pull the lever located under the left-hand side of the instrument panel.

 Do not work on your vehicle without appropriate skills. Switch off the engine and allow it to cool down before working in the engine compartment. Always disconnect the battery before working on any electrical systems or equipment, especially when these are located within the engine compartment. Comply with all applicable instructions and warnings. Failure to work in an informed, professional manner when servicing components and materials constitutes a safety hazard for vehicle occupants and other road users. If you are not familiar with the guidelines, please have the operations performed by your authorized BMW center. ◀



To open

Pull the release handle and open the hood.



To close

Allow the hood to fall from a height of about 12 in (30 cm) so that it audibly engages.

 To avoid injuries, be sure that the travel path of the hood is clear when it is closed, as with all closing procedures. If it is determined that the hood is not completely closed while driving, stop immediately and close it securely. ◀

160 Engine compartment - BMW 525i, 530i

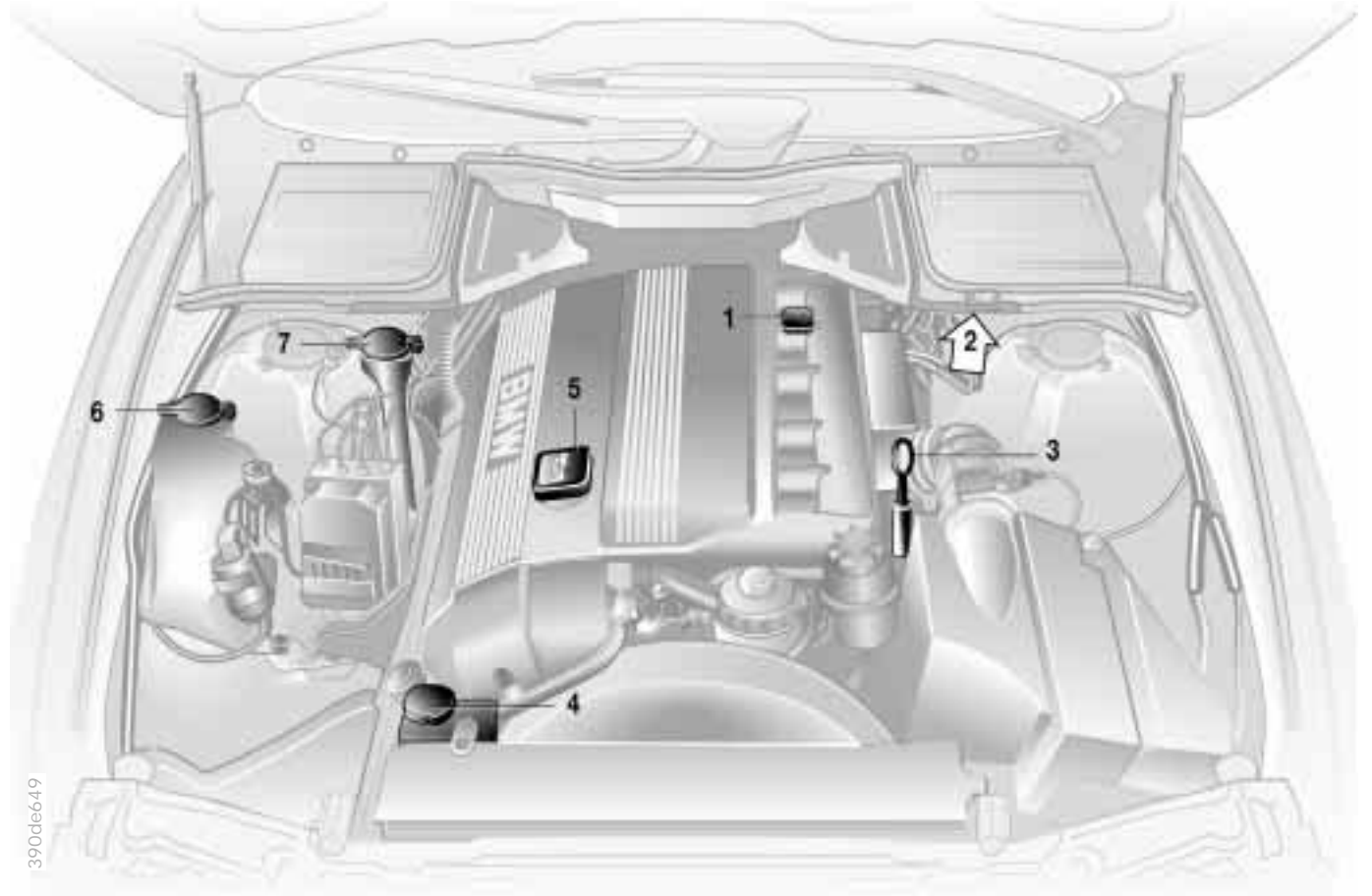

390de649

- 1 Auxiliary terminal for jump starting [200](#)
- 2 Reservoir for brake fluid (under the housing of the microfilter) [168](#)
- 3 Engine oil dipstick [165](#)
- 4 Coolant expansion tank [167](#)
- 5 Engine oil filler neck [165](#)
- 6 Reservoir for intensive-cleaning system* [164](#)
- 7 Reservoir for windshield and headlamp washer system* [164](#)

162 Engine compartment - BMW 540i

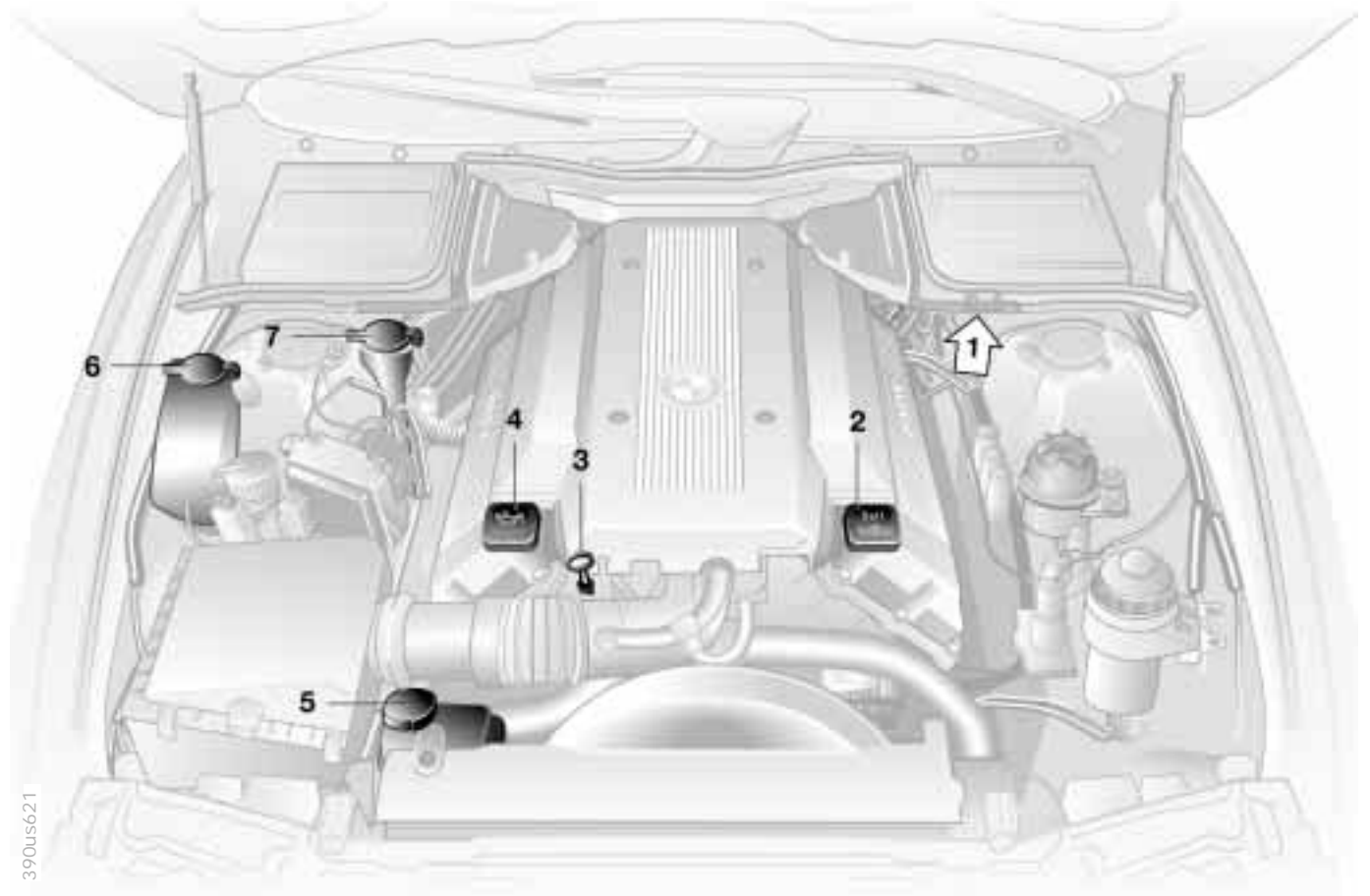

- 1 Reservoir for brake fluid (under the housing of the microfilter) [168](#)
- 2 Auxiliary terminal for jump starting [200](#)
- 3 Engine oil dipstick [165](#)
- 4 Engine oil filler neck [165](#)
- 5 Coolant expansion tank [167](#)
- 6 Reservoir for intensive-cleaning system* [164](#)
- 7 Reservoir for headlamp washer* and windshield washer system [164](#)



Headlamp* and windshield washer system

Capacity in US quarts (liters).

Windshield washer:

approx. 3.7 (3.5) – sedan

approx. 6.3 (6.0) – sport wagon

Incl. headlamp washing system:

approx. 6.3 (6.0)

Fill with water and – if required – with a washer antifreeze (according to manufacturer's recommendations).



We recommend that you mix the washer fluid before adding it to the reservoir. ◀



Intensive-cleaning washer reservoir*

Capacity approx. 1.1 US quarts (1.0 liter).

Fill with intensive-cleaning washer fluid.

It resists freezing to approx. -17 °F (-27 °C) and is available from your BMW center.



Antifreeze agents or intensive-cleaning washer fluids for the washer systems are highly flammable. For this reason, keep them away from sources of flame and store them only in their original containers. Store them so that they are inaccessible to children. Comply with the instructions on the containers. ◀

Washer nozzles

Windshield washer

Windshield:

The spray from the nozzles should be directed so as to ensure effective cleaning, even at high speeds. Use a needle to adjust the nozzles as required, or have them adjusted at your BMW center.

Rear window:

Have this system adjusted by your BMW center as required.

Headlamp washer system

Have the nozzles adjusted by your BMW center as required.



Checking oil level

- 1 Park the vehicle on a level surface.
- 2 Shut the engine off after it has reached normal operating temperature.
- 3 After approx. 5 minutes, pull the dipstick out and wipe it off with a clean lint-free cloth, paper towel, or similar material.
- 4 Carefully push the dipstick all the way into the guide tube and pull it out again.
- 5 The oil level should be in between the two marks on the dipstick.

As with fuel economy, oil consumption is directly influenced by your driving style and vehicle operating conditions.

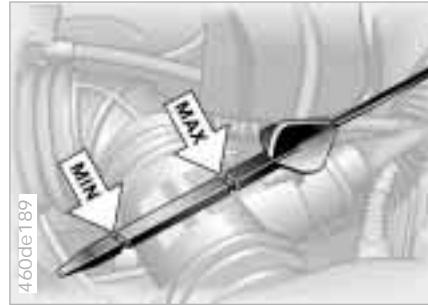

The oil volume between the two marks on the dipstick corresponds to approx. 1.1 US quarts (1 liter). Do not fill beyond the upper mark on the dipstick. Excess oil will damage the engine.



To add oil

Wait until the level has dropped to just above the lower mark before adding oil. However, do not wait until the oil level drops below the lower mark.

 BMW engines are designed to operate without oil additives; the use of additives could lead to damage in some cases. This is also true for the manual transmission, the automatic transmission, the differential, and the power steering system. ◀

Specified engine oils

The quality of the engine oil selected has critical significance for the operation and service life of an engine. Based on extensive testing, BMW has approved only certain engine oils.

Use only approved "BMW High Performance Synthetic Oil."

If you are unable to obtain "BMW High Performance Synthetic Oil," you can add small amounts of synthetic oil in between oil changes. Only use oils with the API SH specification or higher.

 Ask your BMW center for details concerning the specific "BMW High Performance Synthetic Oil" or "synthetic oils" which have been approved. ◀

You can also call BMW of North America at 1-800-831-1117 or visit this website: www.bmwusa.com to obtain this information.

Viscosity ratings

Viscosity is the oil flow rating as established in SAE classes.

The selection of the correct SAE class depends on the climatic conditions in the area where you typically drive your BMW.

 Approved oils are in SAE classes 5W-40 and 5W-30. ◀

These oils may be used for driving in all ambient temperatures.

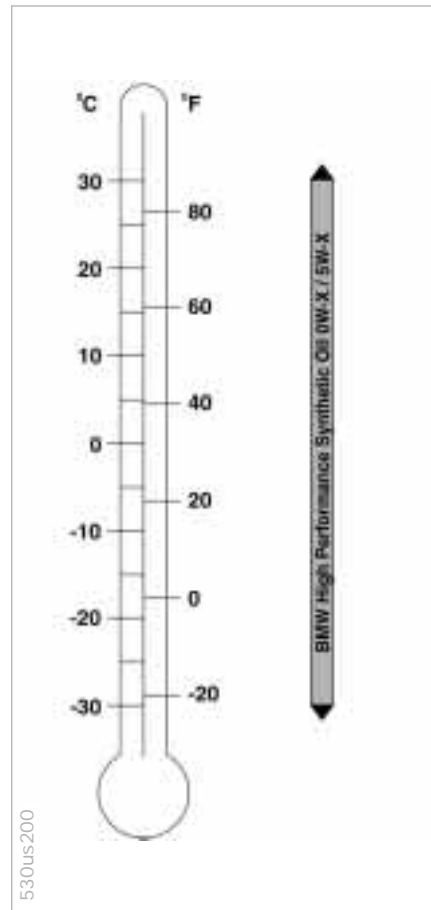

Engine oil

 Comply with the applicable environmental laws regulating the disposal of used oil. ◀

Recommendation: have the oil changed by your BMW center.

 Continuous exposure to used oil has caused cancer in laboratory testing. For this reason, any skin areas that come into contact with oil should be thoroughly washed with soap and water. Always store oil, grease, etc., out of reach of children. Comply with all warning labels and information on lubricant containers. ◀

Coolant

 Do not add coolant to the cooling system when the engine is hot. If you attempt to do so, escaping coolant can cause burns.

To avoid the possibility of damage later on, never use anything other than factory-approved, nitrite and amino-free extended-duty antifreeze with corrosion inhibitor. Your authorized BMW center is familiar with the official specifications.

Antifreeze and anticorrosion agents are hazardous to health. You should always store them in their original container and in a location which is inaccessible to children.

Extended-duty antifreeze with corrosion inhibitor contains the flammable substance ethylene glycol. For this reason, do not spill antifreeze with corrosion inhibitor on hot engine parts. It could catch fire and cause serious burns. ◀

 Comply with the applicable environmental laws regulating the disposal of extended-duty antifreeze with corrosion inhibitor. ◀

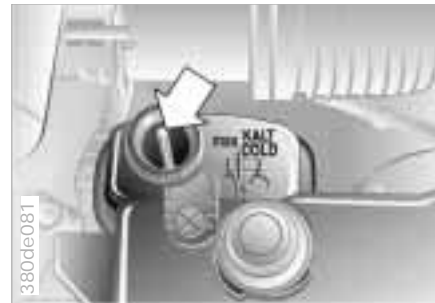

Checking coolant level

Correct coolant level when the engine is cold (approx. 68 °F/20 °C):

Unscrew the cap from the expansion tank.

The coolant level is correct when the upper end of the red float is at least even with the upper edge of the filler neck (refer to the arrow in the illustration), but no more than 0.8 in (2 cm) above it – that is, up to the second mark on the float (refer also to the schematic diagram next to the filler neck).

Adding coolant

Wait until the engine cools before removing the cap from the expansion tank. The needle of the coolant temperature gauge in the instrument cluster must be located in the blue zone; otherwise, there is a danger of scalding.

- 1 Start by turning the cap counterclockwise. Pause to allow any accumulated pressure to escape, then open.
- 2 If the coolant is low, slowly add coolant until the correct level is reached – do not overfill.

The coolant is a mixture of water and extended-duty antifreeze with corrosion inhibitor. Always maintain the prescribed all-season 50:50 mixture ratio for year-round protection against internal corrosion. No other additives are required.

Replace the coolant every four years.

Brake fluid

If the indicator lamp for the brake hydraulic system comes on or if the "CHECK BRAKE FLUID" warning appears in the Check Control*: the brake fluid level is too low in the reservoir.



The brake fluid reservoir is located under the microfilter housing on the driver's side of the car. Should you determine that the brake fluid is low, refer the problem to your BMW center, who can trace and rectify any sources of leakage when refilling the reservoir. Your BMW center is familiar with the specifications for approved brake fluids (DOT 4).

Brake fluid loss results in extended pedal travel. For this situation, refer to the notes on page 146.



Brake fluid is hygroscopic, that is, it absorbs moisture from the air over time.

In order to ensure the safety and reliability of the brake system, have the brake fluid changed every two years by an BMW center. Refer also to the Service and Warranty Information Booklet (US models) or to the Warranty and Service Guide Booklet (Canadian models).

Brake fluid is toxic and damages the vehicle's paint. You should always store it in its original container and in a location which is out of reach of children. Do not spill the fluid and do not fill the brake fluid reservoir beyond the "MAX" mark. The brake fluid could ignite upon contact with hot engine parts and cause serious burns. ◀



Comply with the applicable environmental laws regulating the disposal of brake fluid. ◀



In the engine compartment, stamped on the right-hand strut dome (arrow) and on the upper edge of the instrument panel on the left-hand side.



The BMW Maintenance System has been designed as a reliable means of providing maximum driving and operating safety – and as cost-effectively as possible for you.

Please keep in mind that regular maintenance is not only necessary for the safety of your vehicle, but also plays a significant role in maintaining the resale value of the vehicle.

Service Interval Display

Advanced technology is employed to calculate the optimal maintenance intervals, which are then indicated in the Service Interval Display. While conventional systems rely on distance traveled alone to determine when service is due, the BMW Maintenance System has for years considered the actual conditions under which the vehicle operates, be-

cause mileage can be accumulated in very different ways.

From a maintenance standpoint, 62,000 miles (100,000 km) accumulated in short-distance urban driving are not the equivalent of the same distance covered at moderate speeds in long-distance highway travel.

The BMW Maintenance System includes the Engine Oil Service and Inspections I and II.

Determining the maintenance intervals according to the actual loads on the vehicle covers every kind of operating situation. However, even those who drive only short distances – significantly less than 6,000 miles (10,000 km) annually – should have the engine oil changed at least every 2 years since oil deteriorates over time, regardless of use.

Service and Warranty Information Booklet (US models) or Warranty and Service Guide Booklet (Canadian models)

Please refer to the Service and Warranty Information Booklet (US models) or to the Warranty and Service Guide Booklet (Canadian models) for additional information on maintenance intervals and procedures.

As a precaution against rust, it might be a good idea to have the body checked for damage from rocks or gravel at the same time, depending upon operating conditions.



Have your BMW center do the maintenance and repair.

Your BMW center is always informed on the latest maintenance work and repair techniques and equipped with the required special tools. In addition, checking parts known from experience to be subject to wear is a permanent part of the maintenance specifications.

Be sure that all maintenance work is confirmed in the Service and Warranty Information Booklet (US models) or in the Warranty and Service Guide Booklet (Canadian models).

These entries will constitute your proof that the vehicle has received regular maintenance. They are also required in the event of a warranty claim. ◀

Caring for your car

Washing your car

You can have your new BMW washed in an automatic car wash. Car wash systems that do not employ brushes are preferable.

Wipe away tough dirt and loosen and remove dead insects before washing the vehicle.

To prevent spots, avoid washing when the hood is still warm, or immediately after and during exposure to strong sunlight.

When using an automatic car wash, be sure that:

- ▷ The car wash system is suited for the dimensions of your vehicle.
- ▷ No damage will occur on vehicles with attached body accessories (such as spoilers or antennas). If you are uncertain, consult the manager of the car wash.
- ▷ The wheels and tires of your vehicle cannot be damaged by the conveyance devices of the car wash system.
- ▷ The vehicle is cleaned with minimum brush pressure, and that ample water is available for washing and rinsing.

Vehicles with rain sensor*:

Clean the windshield regularly. Wax from automatic car washes or insects, for example, can cause malfunctions in the function of the rain sensor.



Turn the rain sensor off in automatic car washes. If you do not, damage may occur if the wipers switch on unintentionally. ◀

Parts of the vehicle which are inaccessible to the automatic washer – such as door sills, door and hood edges, etc. – should be cleaned by hand.

In the winter months, it is especially important to ensure that the vehicle is washed on a regular basis. Large quantities of dirt and road salt are difficult to remove, and they also cause damage to the vehicle.



If spray wands or high-pressure washers are used, be sure to maintain an adequate distance between the spray source and the vehicle's surface. Inadequate distance and excessive pressure can damage or weaken the finish, making it more susceptible to subsequent attack. In addition, moisture could penetrate to vehicle components, leading to long-term damage. ◀



When cleaning the headlamps, please observe the following:

- ▷ Do not wipe dry (scratches). Never use abrasives or strong solvents to clean the covers
- ▷ Remove dirt and contamination (such as insects) by soaking with BMW Car Shampoo and then rinsing with plenty of water
- ▷ Always use a deicer spray to remove accumulated ice and snow – never use an ice scraper. ◀



After washing the car, apply the brakes briefly to dry them. Braking efficiency might otherwise be reduced by the moisture, and the brake rotors could also be corroded. ◀

Exterior finish

To provide effective corrosion protection, multilayer paintwork is applied at the factory. Cathaphoretic immersion priming techniques are supplemented using special body-cavity protectants, with the application of specially-developed and extensively tested materials. A layer of flexible PVC is first applied to the undercarriage. Following this, a comprehensive undercoating treatment with a wax-based protectant is applied.

Regular maintenance makes an important contribution to maintaining the safety and value of your vehicle.

Increasing awareness of the effects of harmful environmental factors on vehicle finishes have led paint and vehicle manufacturers to initiate ongoing programs designed to further improve the durability of their finishes. Despite this, environmental factors that occur locally or regionally can have negative effects on the finish of your vehicle. These should guide you in determining the frequency and extent of your efforts to maintain the vehicle finish.

Depending upon material and type of impact (perforation of paint layer), physical stresses from sand, road salt, gravel, etc., can cause corrosion to start extending beneath the finish, starting at the point of impact.

Road dirt, tar spots, dead insects, animal droppings (strong alkali effect) and tree excretions (resins and pollen) all contain substances capable of causing damage when allowed to remain on the finish of your vehicle for any period of time (spots, etching, flaking, separation in the top coat).

In industrial areas, deposits from fly ash, lime, oil deposits, sulfur-dioxide in precipitation (acid rain) and other environmental pollutants will all damage the surface of the vehicle unless adequate protection is provided.

In coastal regions, high levels of atmospheric salt and humidity promote corrosion.

In tropical zones, temperatures of over 105 °F (40 °C) in the shade prevail, in addition to heavy ultraviolet radiation and high humidity. Under those circumstances, light exterior finishes reach temperatures of up to 175 °F (80 °C) and dark finishes up to 250 °F (120 °C).

Caring for your car

Caring for the vehicle finish

Regular washing is a preventive measure against long-term effects from substances that are harmful to the vehicle's finish, especially if you drive your vehicle in areas with high levels of air pollution or aggressive natural substances (tree resins, pollen).

Nevertheless, you should immediately remove especially aggressive substances. Failure to do so can lead to changes in the paint's chemical structure or to discoloration. Gasoline spilled during refueling, oil, grease and brake fluid should always be cleaned away immediately, as should bird droppings (finish damage).

Any contamination remaining on the surface of the vehicle will be especially conspicuous after washing. Use cleaning fluid or alcohol with a clean cloth or cotton pad to remove. Remove tar spots with tar remover. After cleaning, the affected areas should be waxed to ensure continued protection.

 Use cleaning and car-care products that you can obtain at your BMW center. ◀

Waxing your car

Protect the finish using carnauba or synthetic-based waxes only.

The best way to determine when the finish needs to be waxed is by noting when water stops beading on the surface.

You can use a glass cleaner to remove any wax or silicone that may have been left on the windows during waxing.

 Use cleaning and car-care products that you can obtain at your BMW center. ◀

Paint damage

You can touch up small areas of damage with BMW spray paint or a BMW touch-up stick.

The paint color code for your vehicle is provided on a sticker located on the right hand side under the hood and on the first page of your Service and Warranty Information Booklet.

Damage caused by flying stones, scratches, etc., must be touched up without delay to prevent rust from forming.

If corrosion has started to form in an area with paint damage, remove all rust and clean the area. Then prime the area with a BMW Primer Stick. Finally, apply the finish coat. After a few days, polish and protect the touched-in areas.

More extensive paint damage should be repaired professionally in accordance with the manufacturer's instructions. Your BMW center uses original BMW finish materials in accordance with approved repair procedures.

Caring for your car

Window care

You can use window and glass cleaner to clean inside window surfaces and mirrors without smearing and streaking. Never use polishing pastes or abrasive (quartz) cleansers on mirror lenses.

 When caring for break-resistant security glass*, observe the following instructions:

The inner surface of the side windows is coated with a plastic film. For this reason, do not affix any decals or adhesive stickers on the inside of these windows unless they are to be placed there permanently.

Wash the glass with clean water. If necessary, you may add a commercially-available mild household cleaner. Do not use abrasive cleaners.

If the windows are fogged or iced over, treat them with an anti-misting cloth or a deicer spray – do not use an ice scraper. ◀

Clean the wiper blades with soapy water. The wiper blades should be replaced twice a year, before and after the cold season.

 Use only wiper blades which have been approved by BMW. ◀

Caring for other vehicle components and materials

Light-alloy wheels should be treated with alloy wheel cleaner, especially during the winter months. However, do not use aggressive products containing acids, strong alkalis or abrasives. Do not use steam cleaners operating at temperatures above 140 °F (60 °C). (Follow the manufacturer's instructions.)

If your vehicle has chrome parts* such as window moldings, door handles or other items, clean these parts carefully with ample clean water, especially if they have an accumulation of road salt. Use a chrome polish for an additional treatment.

Plastic components, vinyl upholstery, headliners, lamp lenses, the clear cover of the instrument cluster and components with a sprayed dull black surface can be cleaned with water (add plastic cleaner as required). Do not allow moisture to soak through the seats or headliner. Never use solvents such as lacquer thinner, heavy-duty grease remover, fuels, etc.

Rubber components should be cleaned with water only; a rubber treatment or silicone spray may also be applied.

The safety belts should be cleaned with a mild soap and water solution without being removed from the vehicle. Never attempt chemical or dry cleaning, as damage to the belt fabric could result.

After cleaning, never allow the inertia reel to retract the belts until they are completely dry. Dirty safety belts prevent the inertia reel mechanism from retracting the strap properly, and thus constitute a safety hazard.

Heavily soiled floor carpets and mats* can be cleaned with an interior cleaner. The floor mats can be removed from the vehicle for cleaning.

Please use only a damp cloth to clean wooden fascia panels and components. Follow up by drying with a soft cloth.

 Use cleaning and car-care products that you can obtain at your BMW center. ◀

Caring for your car

Leather care

The leather* upholstery used by BMW is a natural product of the highest quality, processed using state-of-the-art methods to ensure that it will maintain its high quality for years to come, provided that it is properly cared for.

Because this product is manufactured using natural materials, you must make allowance for its special characteristics as well as for the peculiarities of its use and care.

Regular periodic cleaning and care are essential, as dust and road dirt act as abrasives in the pores and creases of the material. This leads to wear spots and premature brittleness on the surface of the leather. We therefore suggest that you clean the leather with a vacuum cleaner or dust cloth at frequent intervals.

For cleaning, use BMW leather cleaning foam.

Since dirt and grease gradually affect the protective surface layer of the leather, the cleaned surfaces should be treated with a BMW leather care agent. This also acts as an antistatic agent.

For protection against dampness or moisture, treat the leather with a BMW impregnating agent.

We recommend that you perform this procedure twice a year on leather exposed to normal use.

Spills should be wiped up immediately. Remove grease and oil stains without rubbing, but rather by dabbing with spot remover.

If the upholstery is to be exposed to intense sunlight or if the vehicle is to be stored for an extended period, cover all leather surfaces (or, better yet, the windows) to prevent fading.



Use cleaning and car-care products that you can obtain at your BMW center. ◀



Cleaning agents can contain substances that are dangerous or pose health risks. Therefore, always comply with the warnings and danger notices on the package. Open the doors or windows on your vehicle before cleaning the interior. Never clean your vehicle with cleaning agents (or solvents) not specifically intended for this purpose. ◀

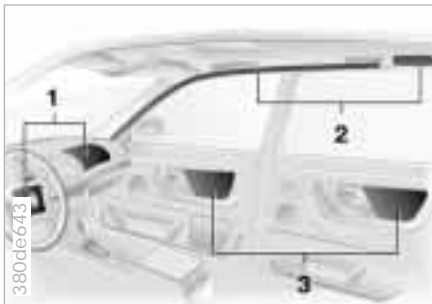

- 1 Front airbags on the driver and passenger sides
- 2 Side impact Head Protection System on the driver and passenger sides (front and rear*)
- 3 Side airbags on the driver and passenger sides (front and rear*)

Important safety notices

 Do not attempt to remove the gas generators of the airbag restraint system from the vehicle. Have testing and service procedures performed by specially-qualified technicians only. In the event of a malfunction, deactivation, or triggered actuation (as a response to an accident) of the airbag restraint system, consult your BMW center for repairs or service operations.

Vehicle storage

Consult your BMW center regarding the required special procedures if you intend to store the vehicle for longer than three months.

Modifications may not be made on either the wiring or the individual components in the airbag system. These include the padded steering wheel hub, the instrument cluster, the side trim panels of the front or rear doors and the roof pillars or the sides of the headliner. Never apply adhesive materials to these components or cover or modify them in any way. Do not attempt to remove or dismantle the steering wheel.

To ensure compliance with official safety regulations, entrust disposal of airbag generators to an BMW center. Unprofessional attempts to service the system could lead to failure in an emergency or undesired airbag activation, either of which could result in personal injury. ◀

Any BMW center will be glad to inform you of the advisability, legal requirements and factory recommendations with regard to technical modifications on the car. For this purpose, the center requires the Vehicle Identification Number and, in some cases, also the engine number.

Light-Emitting Diodes (LEDs)

Light-emitting diodes installed behind translucent lenses serve as the light source for many of the controls and displays in your vehicle. The concept behind their operation is related to that employed for lasers, and they are officially designated as Class 1 light-emitting diodes.

 Do not remove the protective lens and avoid staring directly at the unfiltered beam for extended periods (several hours), as inflammation of the iris could result. ◀

California laws require us to state the following warning:

 Engine exhaust, some of its constituents, and certain vehicle components contain or emit chemicals known to the State of California to cause cancer and birth defects or other reproductive harm. ◀



The Onboard Diagnostic (OBD) socket is located on the left of the driver's side at the bottom of the instrument panel and under a cover (arrow).

The cover has the letters "OBD" on it. The purpose of the OBD system is to ensure proper emission control system operation for the vehicle's lifetime by monitoring emission-related components and systems for deterioration and malfunction.



An illuminated lamp informs you of the need for service, not of the need to stop the vehicle. However, the systems should be checked by your BMW center at the earliest possible opportunity.

Under certain conditions, the indicator will blink or flash. This indicates a rather severe level of engine misfire. When this occurs, you should reduce speed and consult the nearest BMW center as soon as possible. Severe engine misfire over only a short period of time can seriously damage emission control components, especially the catalytic converter.



Service Engine Soon warning lamp for Canadian models.



When the filler cap is not properly tightened, the OBD system can detect the vapor leak and the indicator will light up. If the filler cap is subsequently tightened, the indicator should extinguish within a few days. ◀





Replacement procedures:

Onboard tool kit [182](#)
 Wiper blades [182](#)
 Lamps and bulbs [183](#)
 Changing a wheel [190](#)
 Battery [193](#)
 Fuses [196](#)

In case of electrical malfunction:

Fuel filler door [198](#)
 Sliding/Tilt sunroof [198](#)
 Tailgate [199](#)

Assistance, giving and receiving:

Jump-starting [200](#)
 Towing the vehicle [201](#)

Overview

Controls and features

Operation, care and maintenance

Owner service procedures

Advanced technology

Technical data

Index

Overview

Controls

Car care

Repairs

Technology

Data

Index



Attached to the underside of the luggage compartment lid/tailgate. Unscrew the wingnut for access.

Wiper blades

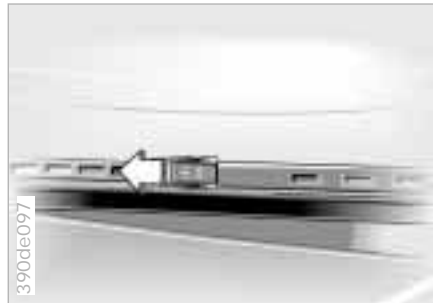

Front

- 1 Pull the wiper arm up slightly and hold it firmly.
- 2 Press back the release (arrow) and pull the wiper blade back toward the base of the wiper arm.
- 3 Install the new blade and slide the release back into position.

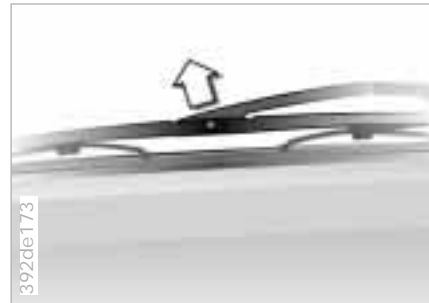

Rear*

- 1 Hold the wiper blade on the window and remove/unclip the wiper arm at the articulated joint (arrow).
- 2 Insert a new wiper blade and press it on/clip it into the wiper arm.



Use only wiper blades approved by BMW. ◀

Lamps and bulbs

The lamps and bulbs make essential contributions to the safety of your vehicle. For this reason, follow the instructions below carefully when replacing a bulb. If you are not familiar with any of the procedures, consult your BMW center.

 Do not touch the glass portion of a new bulb with your bare hands since even small amounts of impurities burn into the surface and reduce the service life of the bulb. Use a clean cloth, paper napkin, or a similar material, or hold the bulb by its metallic base. ◀

A replacement bulb set is available from your BMW center.

 Whenever working on the electrical system, switch off the electrical accessory you are working on or disconnect the cable from the negative terminal of the battery. Failure to do this could result in short circuits. To prevent injuries and damage, comply with any instructions provided by the bulb manufacturer. ◀

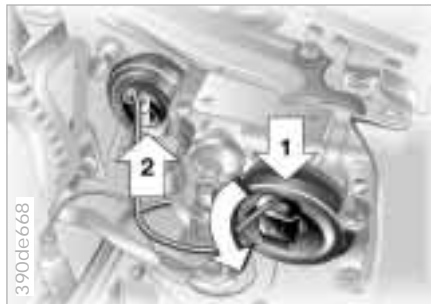

The illustration shows the right-hand engine compartment.

 For checking and adjusting headlamp aim, please contact your BMW center. ◀

1 Low beams

2 High beams

H7 bulb, 55 watts

 The H7 bulb is pressurized. Therefore, wear safety glasses and protective gloves. Failure to comply with this precaution could lead to injury if the bulb is accidentally damaged during replacement. ◀

- 1 Turn the bulb holder to the left (arrow) and remove.
- 2 Remove and replace the bulb.

 When cleaning the headlamps, please observe the following:

- ▷ Do not wipe dry (scratches). Never use abrasives or strong solvents to clean the covers. Remove dirt and contamination (such as insects) by soaking with BMW Car Shampoo and then rinsing with plenty of water. Always use a deicer spray to remove accumulated ice and snow – never use a scraper. ◀

Xenon lamps*

The operating life of these lamp units is extremely long and the likelihood of failure very low, provided that they are not switched on and off a very great number of times. If one of these bulbs should nevertheless fail, it is possible to continue driving with great caution using the fog lamps, provided traffic laws in your area do not prohibit this.

 Because of the extremely high voltages involved, any work on the lighting system should be carried out by technically-qualified personnel only. Otherwise, there is a risk of fatal injury. ◀



Parking lamp

10 watt bulb

 The bulb holder and reflector are a single unit and are both changed at the same time. ◀

- 1 Turn the bulb holder with reflector to the left and remove.
- 2 Disconnect the plug.
- 3 Plug the new bulb holder into the plug connector. Be sure that it is securely engaged.
- 4 Insert the reflector with bulb holder and turn to the right as far as possible.



Front turn signal indicators/ Parking lamps (side marker lamps)

Dual-filament bulb, 21 watt

- 1 Turn the bulb holder to the left and remove.
- 2 Remove and replace the bulb.



Side turn signal indicators

5 watt bulb

- 1 Use finger pressure against the rear end of the lens (arrow) to press it forward for removal.
- 2 Press gently on the bulb and turn it to the left to remove it.

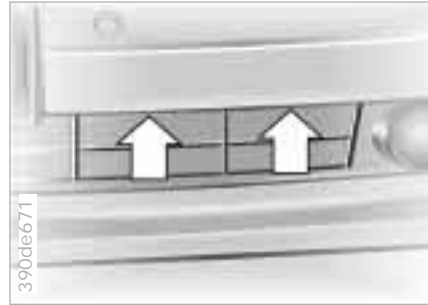

Front fog lamps

H8 bulb, 35 watt

 The bulb is pressurized. Therefore, wear safety glasses and protective gloves. Failure to comply with this precaution could lead to injury if the bulb is accidentally damaged during replacement. ◀

- 1 Using a screwdriver, remove the mounting clip for the air grill (arrow) and remove the grill by bringing it toward the front.

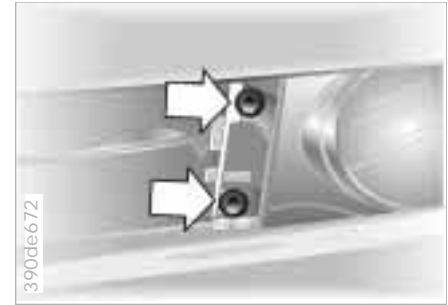

- 2 Loosen both screws (arrows).
- 3 Take off the cover panel next to the headlamp.
- 4 Turn the headlamp 90° to the left and remove it by bringing it toward the front.
- 5 Disconnect the plug.
- 6 Turn the lamp to the left and remove it.

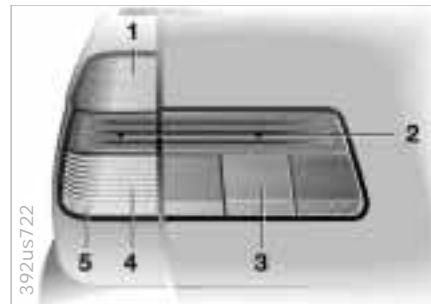
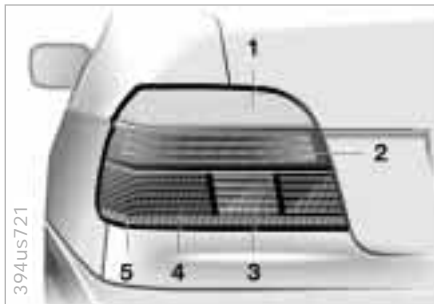

Tail lamps – sedan

Rear lamp/side marker lamps: LEDs
 Remaining bulbs: 21 watts

- 1 Turn signal indicator yellow
- 2 Rear lamp/side marker lamps red
- 3 Backup lamp white
- 4 Brake lamp red
- 5 Reflector red

 Please contact your BMW center if there is a defect in the rear lamp/side marker lamp assembly. ◀

- 1 Use the upper handle to fold down the side panel in the luggage compartment.
- 2 Turn the corresponding bulb holder to the left (arrow) and remove it.
- 3 Press the defective bulb gently and turn it to the left. Remove the bulb and replace it.
- 4 Insert the bulb holder and turn to the right as far as possible.

Tail lamps – sport wagon

Rear lamp/side marker lamps: LEDs
 Remaining bulbs: 21 watts

- 1 Turn signal indicator yellow
- 2 Rear lamp/side marker lamps red
- 3 Backup lamp white
- 4 Brake lamps, reflector red
- 5 Reflector red

 Please contact your BMW center if there is a defect in the rear lamp/side marker lamp assembly. ◀



Lamps in the rear apron panel:

- 1 Open the cover in the side panel.
- 2 Turn the quick-release fastener and remove the trim panel in front of the bulb holder.
- 3 Open the quick-release fastener (arrow) and remove the bulb holder.
- 4 Apply gentle pressure to the bulb while turning it to the left to remove.

If a subwoofer* is installed behind the right-hand panel, unscrew the T-screw and swing the subwoofer to the side.



Lamps in the luggage compartment lid/tailgate:

- 1 Open the trim panel in the luggage compartment lid/tailgate.
- 2 Open the quick-release fastener (arrow) and remove the lamp holder.
- 3 Apply gentle pressure to the bulb while turning it to the left to remove.



Center (high-mount) brake lamp

21 watt bulb

- 1 Open the luggage compartment lid.
- 2 Unclip the cover panel (on the underside of the parcel tray) with a screwdriver (arrow).
- 3 Turn the bulb holder to the left and remove.
- 4 Apply gentle pressure to the bulb while turning it to the left to remove.

sport wagon: LED strip in the tailgate.
Please contact a BMW center in case of a malfunction.



License plate lamps

5 watt bulb

- 1 Insert a screwdriver into the slot and press to the left (arrow); this disengages the lamp.
- 2 Remove the lamp and replace the bulb.

Interior lamps

Front

Interior lamp (10 watt bulb) with reading lamps (10 watt bulbs)

- 1 Interior lamp: press the lamp out to the side with a screwdriver and remove the lens. Pull the bulb from the contacts.
- 2 Reading lamp: gently press against the lamp while turning it to the left to remove.

Indirect lighting

1 watt bulb

- 1 Unclip the lamp holder.
- 2 Remove the bulb.

Rear – sedan

Interior lamp (10 watt bulb) with reading lamp (5 watt bulb)

- 1 Use a screwdriver on the upper recesses to pry out the lamp.
- 2 Interior lamp: push back the tab on the reflector and replace the bulb.
- 3 Reading lamp: gently press against the lamp while turning it to the left to remove.

Rear – sport wagon

Interior lamp: 5 watt bulbs

- 1 Use a screwdriver to pry out the lamp from above.
- 2 Remove the lens.
- 3 Replace the bulb.

Interior lamp (10 watt bulb) with reading lamp (6 watt bulb)

- 1 Using a screwdriver, press the lamp next to the button out to the side.
- 2 Remove the lens.
- 3 Replace the bulb.

Lamps and bulbs

Footwell lamps

5 watt bulb

- 1 Use a screwdriver to press the lens out to the side.
- 2 Replace the bulb.

Glove compartment lamp

5 watt bulb

- 1 Apply a screwdriver to the recess to pry the lamp out.
- 2 Remove the reflector.
- 3 Replace the bulb.

Luggage compartment lamps – sedan

Lamp on the underside of the rear parcel tray: halogen lamp, 10 watt

Lamp in the luggage compartment lid: 10 watt bulb

- 1 Apply a screwdriver to the recess to pry the lamp out.
- 2 Remove the reflector.
- 3 Replace the bulb.

Luggage compartment lamps – sport wagon

Headliner lamps: 10 watt bulbs

- 1 Use a screwdriver to push the lens to the side.
- 2 Replace the bulbs.

Lamps on the apron of the tailgate: 10 watt bulb

- 1 Use a screwdriver to pry out the lamp at the upper edge.
- 2 Remove the reflector.
- 3 Replace the bulb.



Safety measures in the event of a flat tire or wheel change:

Stop the vehicle as far as possible from passing traffic. Park on a firm, flat, surface. Switch on the hazard warning flashers.

Turn the steering wheel to the straight-ahead position, remove the key and engage the steering lock. Shift into 1st or reverse (selector lever in Park with automatic transmission) and engage the parking brake.

All passengers should be outside the vehicle and well away from your immediate working area (behind a guardrail, for instance).

If necessary, set up your warning triangle or portable hazard warning lamp on the roadside at an appropriate distance from the rear of the vehicle. Comply with all safety guidelines and regulations.

Change the wheel only on a level, firm surface which is not slippery. Avoid jacking the vehicle on a soft or slippery support surface (snow, ice, loose gravel, etc.), since it could slide sideways.

Position the jack on a firm support surface.

Do not place wooden blocks or similar objects under the jack. If this is done, the jack might not be able to reach its full support capacity because of the limited height.

Do not lie under the vehicle or start the engine when the vehicle is supported by the jack – risk of fatal injury. ◀



What you will need

In order to avoid rattling noises later, note the position of the tools when you remove them and return them to their original position when you are through using them.

- ▷ Car jack
 - sedan: fold back the luggage compartment floor mat for access, then unscrew the wingnut to release the jack (arrow).
 - sport wagon: raise the floor panel and spare tire cover (refer to page 134).
 - When you have completed work, screw the jack all the way back down. Fold the handle back and insert it in its holder
- ▷ Wedge (wheel chock)
 - Located next to the jack. Loosen the wing nut to remove it

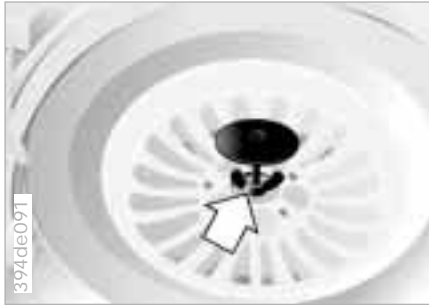

- ▷ Spare tire and adapter* for removing the lug bolt cover* (refer to the next column)
Both are next to the jack. Remove the adapter or the plastic cover. Unscrew the wing nut (arrow) by hand and remove the wheel
- ▷ Lug wrench and screwdriver
In the onboard tool kit under the luggage compartment lid (refer to page 182).
sport wagon: the lug wrench is next to the spare tire.

Procedure

- 1 Read carefully and comply with the safety precautions on the previous page.
- 2 Secure the vehicle against rolling: Place the wedge against the rear surface of the front tire on the side opposite the side being raised. If the vehicle is parked on a downward slope, place the wedge securely in front of the tire. If the wheel must be changed on a surface with a more severe slope, take additional precautions to secure the vehicle from rolling.
- 3 Wheels with full wheel covers*: Reach into the ventilation openings and pull the cover off.



- 4 Wheels with adapter*: position the lug bolt adapter on the lug bolt cover. Then apply the lug wrench and turn it to the left (refer to the illustration).
- 5 Wheels with hub cover*: pry the hub cover off with the screwdriver in the slot.
- 6 Loosen the lug bolts ½-turn.

192 Changing a wheel



- 7 Position the jack at the jacking point closest to the flat tire so that the jack base is vertically below the jacking point and the entire surface of the head of the jack will move into the square recess of the jacking point (refer to the illustration detail) when the jack is cranked.
- 8 Jack the vehicle up until the wheel you are changing is raised off the ground.
- 9 Unscrew the lug bolts and remove the wheel.
- 10 Remove accumulations of mud or dirt from the mounting surfaces of the wheel and hub. Clean the lug bolts.



- 11 Position the spare wheel. Secure the wheel by turning at least two lug bolts into opposite bolt holes.
- 12 Screw in the remaining lug bolts. Tighten all the bolts securely.
- 13 Lower the jack and remove it from beneath the vehicle.
- 14 Tighten the lug bolts in a diagonal pattern.
- 15 Wheels with full wheel covers: Place the wheel cover with the valve opening over the valve (arrow). Use both hands to press the cover securely onto the rim.

 For this light-weight wheel, use only the full wheel cover installed by the factory. Other wheel covers may not fit securely. ◀

- 16 Wheels with hub covers: Position the hub cover and press it on tightly.
- 17 If equipped with lug bolt covers: Align the arrow on the cover with the line in the wheel and press the cover into place.
- 18 Check and correct the air pressure at the earliest opportunity. For vehicles with Tire Pressure Control (RDC)*: After mounting the spare tire or correcting the inflation pressure, reactivate the system. Refer to page 103.

 The vehicle jack is designed for changing tires only. Do not attempt to raise another vehicle model with it or to raise any load of any kind. To do so could cause accidents and personal injury. To ensure continued safety, have the lug bolts checked with a calibrated torque wrench [torque specification 72 lb-ft (100 Nm)] at the earliest opportunity. ◀

Changing a wheel

When storing the wheel, take care to ensure that you do not damage the retaining pin in the spare tire recess.

If light-alloy wheels other than original BMW light-alloy wheels have been mounted, it may be necessary to use different lug bolts for those wheels.

Replace the defective tire as soon as possible and have the new wheel/tire balanced.

 Size 255/40 R17 94 W* tires on the rear axle:

In the event of a puncture or other tire failure, it may be necessary to mount the spare tire of different size at the rear. This tire is of full capacity in all load and speed ranges. Nevertheless, mount a tire of the correct size as soon as possible. ◀

Battery



 Battery posts, terminals, and related accessories contain lead and lead compounds. Wash hands after handling. ◀

Installation location

The battery is located behind the right-hand side trim panel in the luggage compartment.

Fold the trim panel down with the handle at the top. On the sport wagon, press the button.

If a subwoofer* is installed on the sport wagon, loosen the T-screw and swing the subwoofer to the side.

Maintenance

The battery is absolutely maintenance-free, that is, the original electrolyte will normally last for the service life of the battery under moderate climatic conditions.

Symbols

You will find the following symbols on your vehicle battery. To avoid injury, please comply with the corresponding precautions whenever you work with or near the battery.



Please read the following information before working with the battery.



Wear eye protection. Do not allow particles containing battery acid or lead to come into contact with your eyes, your skin, or your clothing.



Battery acid is extremely corrosive. Wear eye protection and protective gloves. Do not tip the battery. Battery acid can leak from the ventilation openings.



Be sure that children keep well away from batteries and battery acid.



Never allow sparks or open flame near the battery. Do not smoke in the vicinity of the battery. Avoid sparks from electrical cables or electrical equipment. Turn the key to position 0 in the steering lock during the disconnection or connection of the battery. Never short-circuit the battery terminals. There is a danger of injury from powerful sparks.



A highly-explosive gas is generated when the battery is charged.



If you happen to get acid in your eyes, rinse thoroughly for 15 minutes with clear water.

Following that, consult a physician immediately. If you get acid spray on your skin or clothing, rinse with plenty of water. If electrolyte is accidentally swallowed, consult a physician immediately.



In order to protect the battery case from ultraviolet radiation, do not place it in direct sunlight. A discharged battery can freeze. Store the battery in areas where the temperature remains above freezing.



Charge condition

You can read the charge condition of the battery with the "Magic Eye"* (a hydrometer):

- ▷ Green: adequate charge.
- ▷ Black: not charged adequately. The battery must be recharged. Please contact your BMW center.
- ▷ Yellow: replace the battery.



The projected service life of the battery can only be reached if the battery is fully-charged at all times. Check the charge condition of the battery frequently if the vehicle is used primarily for driving short distances. ◀

Charging the battery

If the battery is charged in the vehicle: Do not charge the battery with the engine running.



Before performing any work on the electrical system, disconnect the cable from the negative terminal. If you do not, short circuits can create the risk of fire or personal injury. ◀

If you plan to store the vehicle for more than four weeks, disconnect the battery from the vehicle electrical system by disconnecting the cable at the negative terminal and then recharge using a suitable charging device.

If you intend to store your vehicle for longer than 12 weeks: remove the battery, charge it and store it in a cool (but frost and dust-free) room. Every three months and before reinstalling the battery, have it recharged. If it is not recharged, it will not be serviceable. Every time the battery is discharged, especially over extended periods, its service life is reduced.

Battery

 Return used batteries to a recycling point or your authorized BMW center. Maintain the battery in an upright position for transport and storage. Secure the battery against falling over in transit. ◀



Removal and installation

 Do not disconnect the battery when the engine is running. Disconnecting the battery cable when the engine is running will cause a voltage surge which will damage the vehicle's onboard electronics.

Do not make any modifications in the wires to the positive terminal. If you do so, the protective function of the safety battery terminal is no longer ensured. Repairs and disposal may only be performed by specially-trained personnel. ◀

When removing the battery, first disconnect the negative terminal, then the positive terminal. Remove the protective bar 1 and unscrew the threaded connection of the battery bracket 2. When installing the battery, connect the positive terminal first, then connect the negative terminal.

 When installing a battery, be sure that it is mounted properly. Install and secure the protective bar. If the battery is not mounted and fastened properly, it will not be adequately secured in case of an accident. ◀



When an electrical accessory fails to operate, switch it off and inspect the fuse.

In the glove compartment

- 1 Open the glove compartment and turn the two white quick-release fasteners to the left. Spare fuses and plastic tweezers are located on the fuse holder.
- 2 Use the plastic tweezers to remove the fuse for the accessory or equipment that has stopped working.
- 3 If the fuse is burned through (the metal strip will have melted and separated), replace it with a new fuse of the same ampere rating (color code).

The fuses, their respective ampere ratings and the equipment in their circuits are all indicated below the fuse holder.

Close the fuse holder by holding the top of the cover in place and screwing the two quick-release fasteners to the right.

Additional fuses are provided in the luggage compartment (refer to next columns).

The fuse for continuous positive current is located in a separate fuse box above the battery. If this fuse is defective, refer the problem to your BMW center for repair.



Do not attempt to repair a burned fuse or replace it with a fuse having a different color or ampere rating. To do this could cause a fire in the vehicle resulting from a circuit overload. ◀

If the fuse fails repeatedly, refer the problem to your BMW center for repair.



In the luggage compartment

Use the handle to pull down the trim on the right wall.

A list of the fuses, their respective amperage ratings and the equipment in their circuits is provided on the rear of the side trim.



In the luggage compartment - sport wagon

Open the right access door by pressing the button and pull the trim panel to the side.

A list of the fuses, their respective amperage ratings and the equipment in their circuits is provided on the rear of the side trim panel.

If a subwoofer* is installed, loosen the T-screw and swing the subwoofer to the side.

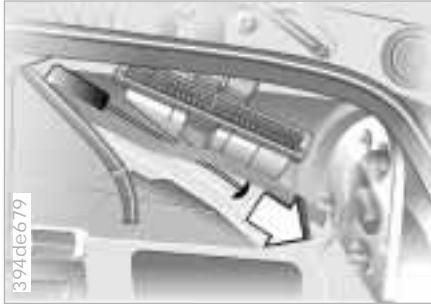

Manual release - sedan

- 1 Use the handle to lower the trim panel on the right side of the luggage compartment.
- 2 Pull the knob with the fuel pump symbol (arrow).



Manual release - sport wagon

- 1 Release the right-hand panel in the luggage compartment with the button and fold the panel down.
- 2 Pull the knob with the fuel pump symbol (arrow).

If a subwoofer* is installed, loosen the T-screw and swing the subwoofer to the side.



Manual operation

- 1 Remove the interior lamp (refer to page 188), reach into the opening and push out the panel.
- 2 Use the Allen key from the onboard tool kit (refer to page 182) to turn the sliding/tilt sunroof in the desired direction.

Tailgate

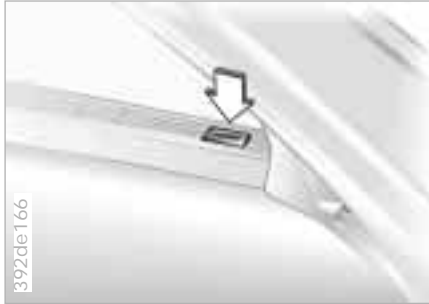

Manual release – sport wagon

In the event of an electrical malfunction, you can release the tailgate manually:

- 1 From inside the luggage compartment, open the two side covers (arrow). Remove the covers.
- 2 Release the two quick-release fasteners of the cover for the onboard tool kit in the tailgate. Raise the cover.
- 3 Remove the plastic plugs (arrow) and pull toward the interior. The tailgate will be released.
- 4 Open the tailgate. Press the plugs back into place and close the cover with the quick-release fasteners.
- 5 Position the two side covers and close them.

200 Jump-starting

Never use spray starter fluids.

If the battery is discharged, the engine can be started with the use of two jumper cables and the battery of another vehicle. Always use jumper cables with fully insulated handles on the terminal clamps.

 Do not touch high-voltage wiring and cables on a running engine. There is a risk of fatal injury if you do this. ◀

Carefully comply with the following instructions to avoid personal injury and damage to one or both vehicles:

- 1 Ensure that the battery on the support vehicle is also rated at 12 volts, and that the capacities of the two batteries (Ah) are roughly comparable (printed on casing).
- 2 Leave the discharged battery connected to the vehicle electrical system.
- 3 Make sure that there is no contact between the bodywork of the two vehicles – short circuit risk.



- 4 Start by connecting the jumper cable from the positive terminal of the support vehicle to the positive terminal connector located in your BMW's engine compartment. The cover of the auxiliary terminal for jump starting is marked with a "+" sign (refer to the illustration). Pull up to open the cover. The illustration shows the external positive terminal connector of the BMW 540i. For the BMW 525i, BMW 530i refer to "Engine compartment" on page 160.

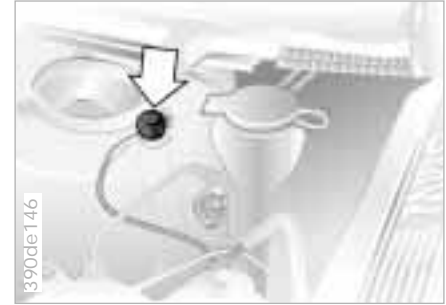

- 5 Then connect the negative terminals. Attach the cable to either the support vehicle's negative battery terminal, or to a suitable ground on its engine or bodywork. Then connect the other end of the cable to a ground on the engine or body of the vehicle which is to be started. There is a special nut on the strut dome of your BMW; refer to the arrow in the illustration.

 Follow the same sequence for connecting the jumper cables if you assist in jump-starting another vehicle. If you do not, there is a risk of injury caused by spark generation at the battery. ◀

Jump-starting

- 6 Start the engine of the support vehicle and let it run.
- 7 Start the engine on the vehicle needing the jump-start, and allow it to run as usual. If the first start attempt is not successful, wait a few minutes before another attempt in order to allow the discharged battery to recharge.
- 8 Before disconnecting the jumper cables from your BMW, turn on the headlamps, the rear window defroster and the highest blower speed and allow the engine to run at least 10 seconds to prevent a voltage surge at the voltage regulator.
- 9 Then disconnect the jumper cables in the opposite order.

Have the battery recharged if necessary.

Towing the vehicle



Tow fitting

The screw-in tow fitting is stored in the onboard tool kit; be sure that it remains in the vehicle at all times. This fitting is designed for installation in the tow sockets located at the front and rear of the vehicle, and is intended for towing on proper road surfaces only. It should not be used to pull a vehicle out of deep snow, mud, sand, etc. Always observe all applicable towing laws and regulations.

Access to tow sockets

Front:

Apply pressure to the arrow symbol on the cover panel to remove.



Rear:

Apply pressure to the arrow symbol on the cover panel to remove.

 Screw the tow fitting in until it bottoms firmly. If this is not done, the threads could be damaged. Never attach tie-down hooks, chains, straps, or tow hooks to tie rods, control arms, or any other part of the vehicle suspension, as severe damage to these components will occur, leading to possible accidents. ◀

Use only a nylon towing strap to tow the vehicle, since the inherent resilience of this material helps protect both vehicles from sudden jerking movements.

 The towed vehicle should always be the lighter of the two vehicles. If this is not the case, it is no longer possible to control vehicle response. ◀

Tow-starting

It is not possible to start the engine of vehicles equipped with an automatic transmission by towing or pushing.

For instructions on jump starting, refer to page [200](#).

Never attempt to use your vehicle to push another vehicle, since damage to the energy-absorbing bumpers could result.

Towing a vehicle with automatic transmission

- 1 Place the selector lever in position N.
- 2 Towing speed:
Max. 45 mph (70 km/h).
- 3 Towing distance:
Max. 95 miles (150 km).
- 4 Leave the ignition key in position 1 to ensure that the brake lamps, turn signals, horn and windshield wipers remain operative, and to prevent the steering lock detent from engaging.
- 5 Switch on the hazard warning flashers (observe country-specific regulations).

Find some means of identifying the vehicle in tow, for instance, place a sign or warning triangle in the rear window.

 Make sure that the ignition key remains in position 1 even when the electrical system has failed to prevent the steering lock from engaging. The steering and brakes are without power assist when the engine is off. This means that increased effort is required for steering and braking. ◀

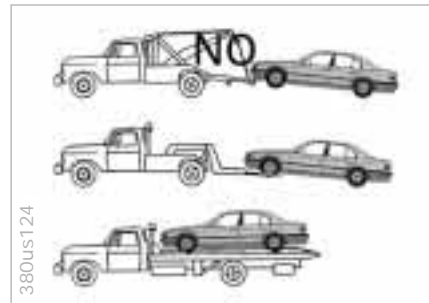

Towing with a commercial tow truck

- ▷ Do not tow with sling-type equipment.
- ▷ Use a wheel lift or flat bed carrier.
- ▷ Please comply with applicable towing laws.

 Never allow passengers to ride in a towed vehicle for any reason. ◀



Overview

Controls and features

Operation, care and maintenance

Owner service procedures

Advanced technology

Technical data

Index



Airbags [206](#)
Adaptive Transmission Control (ATC) [207](#)
Automatic Stability Control plus Traction (ASC+T)/Dynamic Stability Control (DSC) [208](#)
BMW active seat [210](#)
Safety belt tensioner [210](#)
DSP sound system [211](#)
Mirrors with automatic dimmer [211](#)
Rain sensor [212](#)
Tire Pressure Control (RDC) [213](#)
Integrated rear suspension Level control system [214](#)
Xenon lamps [215](#)



Deceleration sensors continuously monitor the physical forces acting upon the vehicle. If, as the result of a frontal collision, vehicle deceleration is reached at which the protection of the safety belts alone is no longer adequate, the gas generators of the driver-side and passenger-side airbags are ignited simultaneously. However, the front airbag on the passenger-side is only triggered if an additional sensor has recognized that the passenger seat is occupied.

Depending on which side the vehicle is involved in a side collision, the head protection and side airbags in the front and rear* are triggered if necessary.

The airbags located under the marked covers inflate and unfold in a matter of a few milliseconds. In this process they tear through the rated breaking points of the upholstered covers or press them out.

Because the inflation process must be virtually instantaneous, it is necessarily accompanied by a certain amount of ignition and inflation noise. The gas which the system employs to inflate the airbag is not dangerous. Smoke appears as the gas dissipates.

The entire process is completed within fractions of a second.



On vehicles with automatic transmission, Adaptive Transmission Control (ATC) uses a number of factors to calculate the gear which provides the maximum efficiency. In this process it monitors your personal driving style, the situation in which you are driving, the condition of the road and the traffic conditions.

ATC recognizes your personal driving style from the positions and movements of the accelerator pedal, deceleration when braking and lateral acceleration through curves. Four different shift characteristics – from comfort-oriented to performance-oriented – are available for selection by ATC.

In order to take driving conditions into account, ATC registers corners and

both uphill and downhill gradients. For example, if you maintain speed through a curve, the transmission does not up-shift.

On uphill gradients, it shifts only when the engine speed increases in order to make more efficient use of power reserves. On downhill gradients ATC downshifts when the speed of the vehicle increases, causing the driver to step on the brakes.

Precision sensors monitor the number of revolutions of the wheels. When equipped with DSC, they also monitor steering angle, lateral acceleration, brake pressure and the movement of the vehicle around its vertical axis.

If differences in the wheel speeds occur, the system counteracts the danger of wheelspin by reducing torque. If necessary, the system also responds with additional brake applications at the rear wheels, and at all 4 wheels with DSC.

In addition, DSC permanently monitors the vehicle's current operating condition and compares it with an ideal condition that is calculated from the sensor's signals. If deviations from this occur (understeering or oversteering, for instance), DSC can stabilize the vehicle in the fraction of a second by reducing engine output and with the assistance of braking intervention at individual wheels. As a result, dangerous skids can be prevented even as they are just beginning.

You may need some time to become accustomed to this system intervention. However, it guarantees optimum drive force and driving stability.

The braking intervention may be accompanied by a certain degree of noise.

Radio reception

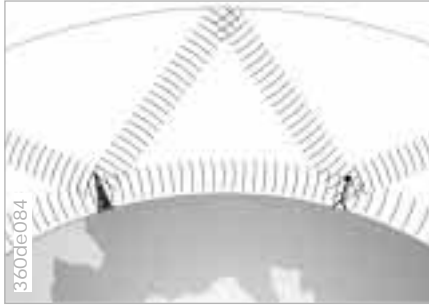

The AM frequency bands (medium-wave, long-wave and short-wave) make it possible to receive stations from a great distance, because the broadcast signals travel not only along the ground as surface waves, but also as atmospheric waves that are reflected from the ionosphere.

Frequency-modulation (FM) provides substantially better sound quality than AM. However, because FM transmissions rely on line-of-sight broadcast waves, their effective reception range is limited.

Although numerous factors combine to impose inherent limitations on the reception quality available from mobile radios, specially designed systems can be employed to minimize their effects:

The Diversity Antenna system employs several FM antennas integrated within the rear window to provide three separate sources for receiving broadcast waves. An integral processor automatically selects the antenna with the best FM reception quality at any given time. Because the ongoing antenna selection process is completed within milliseconds, it remains inaudible to the radio listener.



BMW seats are configured for your orthopedic well-being. The active seat is an engineering enhancement of BMW's seats, designed to ensure less fatigue during extended trips while sitting with little movement. The seat is no longer a passive element between the road, the running gear and the passenger. Instead, it creates minor and imperceptible shifts in your weight by an active change in the contour of the seat surface. The basic seat position is not changed as this occurs. Fluid cushions are located below the surface of the seat in the seat's upholstery on the left and right.

The fluid is circulated slowly back and forth between the two cushions by means of a pump. This causes a movement of the spinal column which is nearly unnoticeable, resulting in an improved flow of blood to the vertebral discs and the muscles in the area of the spinal column. Vehicle occupants can experience less muscle cramping, back pain in the spine's lumbar region and fatigue. The active seat thus provides a significant contribution to your driving comfort and safety.



The safety belt tensioner responds to severe frontal collisions by tightening the belts to ensure that occupants remain firmly positioned in their seats. A gas-pressure system retracts the buckle assembly to tension the shoulder and lap belts within fractions of a second. This reduces the tendency to slide under the lap belt.

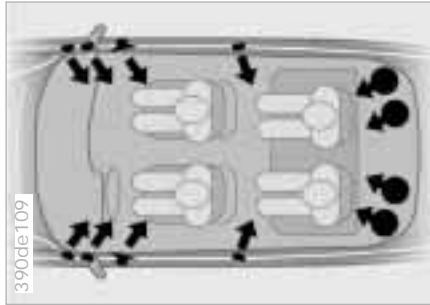

The DSP professional premium sound system features a special amplifier combined with Digital Sound Processing (DSP) and integrated speakers to surround you with crisp, true-to-life sound reproduction.

The speaker system's subwoofers, woofers, midrange speakers and tweeters furnish you with an impressively full-bodied listening experience. The individual components are oriented so as to produce the aural sensation that you would experience facing the stage in a concert hall. The system also automatically adjusts the bass and treble settings to compensate for changes in volume and vehicle speed.



The interior and exterior mirrors with automatic dimming feature reduce the glare from following traffic by adapting the intensity of the reflected images to correspond to levels of light registered by the unit's sensors. The mirrors revert to their undimmed setting as soon as the light source disappears.

One sensor is mounted on the front of the interior mirror housing and is designed to monitor light levels in the area immediately forward of the vehicle. A second sensor is integrated within the mirror's glass.

The electronic control system operates by comparing the respective levels of luminous intensity in front of and behind the car. The difference provides the basic parameter used to modulate an electrical current and induce chemical changes in a semisolid layer incorporated in the lens.

The semisolid reacts chemically to this electrical current, thus providing infinitely-variable dimming of the mirror (electrochromic technology).

As a result, it is no longer necessary to dim the mirror manually, and the driver can maintain full concentration on traffic.

212 Rain sensor*

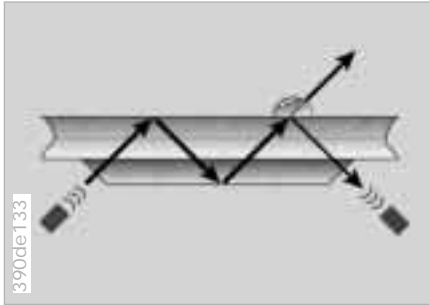

When the system is set to the "Intermittent" wiper speed, the wipers react immediately – if water is splashed onto the windshield by vehicles traveling ahead of you, for example. As a result, the rain sensor provides a contribution to driving safety and comfort.

Depending on the degree of wetness on the windshield, the rain sensor controls the operation of the windshield wipers.

Infrared light is carried along the surface of the windshield in an optical conductor in such a manner that it is reflected completely when the windshield is dry. The quantity of reflected light is measured.

If the window is covered with beads of water, the amount of light that is reflected is decreased since the infrared light at the surface of the windshield can then escape. The quantity of reflected light is thus a means of gauging the degree of wetness on the windshield.



Near every wheel, there are antennas in the body which receive the signals from all four wheels. A central electronics system evaluates the quadruple signals and forwards any changes.

The RDC provides an important contribution to driving safety.

The Tire Pressure Control system (RDC) assumes the task of regular tire pressure checks for you. The tire pressure is monitored at all four wheels, even when the vehicle is moving.

Behind the valve stem in every wheel, there is an electronic chip which is designed for severe-duty applications and long service life. It contains a pressure sensor, a transmitter and a battery. The pressure is measured in extremely short time intervals and then transmitted by a radio signal. If an irregularity is detected, the transmission rate is increased.

214 Integrated rear suspension

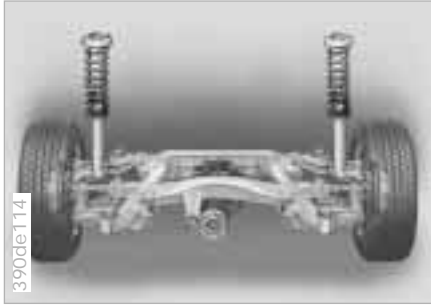

The illustration shows the rear axle of the sedan. With the lightweight, compact rear axle of the sport wagon, the shock absorbers are positioned at an angle.

The control arms on the patented integrated aluminum rear axle assembly are not mounted directly on the body. They are mounted elastically on a chassis sub-frame which is joined in turn with elasticity to the vehicle body. The resulting double elastic suspension system effectively absorbs the forces resulting from bumps and road surface irregularities.

The compliance rates of the integrated rear axle assembly's control arm mounts have been precisely calibrated to help provide supplementary adjustment in the tracking angle of the rear wheels (programmed self-steer effect). The ultimate result is enhanced safety and control under all conditions.

Level control system*

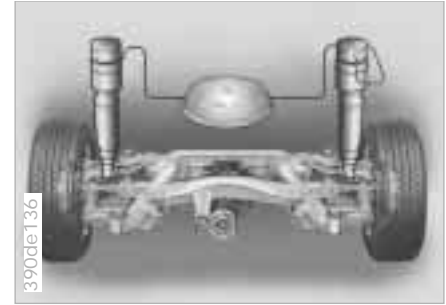

The level control system for the rear axle maintains constant ground clearance of your vehicle, even when carrying a load.

To achieve this, the vehicle is equipped with air struts at the rear axle instead of conventional shock absorbers and steel suspension springs. With the help of two sensors, an electronic control unit calculates the height of the body at all times and, if it is required, it allows air which is generated in a compressor to flow into the air springs.

As a result of the pressure increase in the air springs, the level control system ensures not only constant ride height, but also ride comfort which is independent of the load the vehicle is carrying.

Xenon lamps*

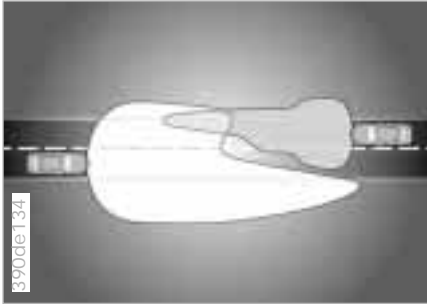

The xenon lamps light up the side and front areas of the vehicle with significantly more brightness and uniformity than the traditional halogen lamps.

In a xenon lamp, an electric arc replaces the filament in order to generate intense illumination. A gas mixture in a quartz glass tube with metal vapor is ignited by a high electric voltage. The arc that is generated is then sustained by a lower voltage.

When the lamp is turned on, a brief period is needed for the full beam strength to build up. Maximum brightness is attained in approx. 15 seconds.

Xenon lamps provide significantly improved visibility, especially during adverse weather conditions and driving situations (driving at night in heavy rain or through road repair areas where there are no lane markers, for instance).

Vehicles with xenon lamps are equipped with automatic headlamp range control. As a result, the highway is always optimally lighted, regardless of load conditions, and drivers in on-coming traffic are not blinded.

Xenon lamps make a significant contribution to highway safety since other highway users, or bicyclists and motorcyclists in the right lane, and pedestrians are more easily detected.

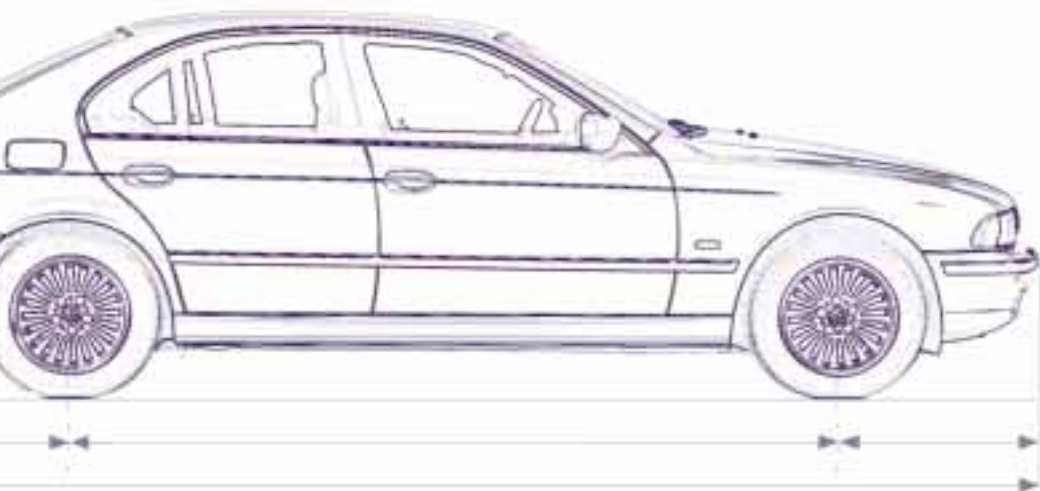

Engine specifications 218
Dimensions 219
Weights 221
Capacities 223
Electrical system 224
Drive belts 224



Overview

Controls and features

Operation, care
and maintenance

Owner service procedures

Advanced technology

Technical data

Index

Overview

Controls

Car care

Repairs

Technology

Data

Index

218 Engine specifications

		BMW 525i/sport wagon	BMW 530i	BMW 540i/sport wagon
Displacement	cu in (cm ³)	152.2 (2,494)	181.8 (2,979)	268.4 (4,398)
Number of cylinders		6	6	8
Maximum output at engine speed	hp rpm	184 6,000	225 5,900	282 5,400
Maximum torque at engine speed	lb ft (Nm) rpm	175 (236) 3,500	214 (289) 3,500	324 (440) 3,600
Compression ratio	ϵ	10.5	10.2	10.0
Stroke	in (mm)	2.95 (75.0)	3.53 (89.6)	3.26 (82.7)
Bore	in (mm)	3.31 (84.0)	3.31 (84.0)	3.62 (92.0)
Fuel-injection system		Digital-electronic engine-management system		

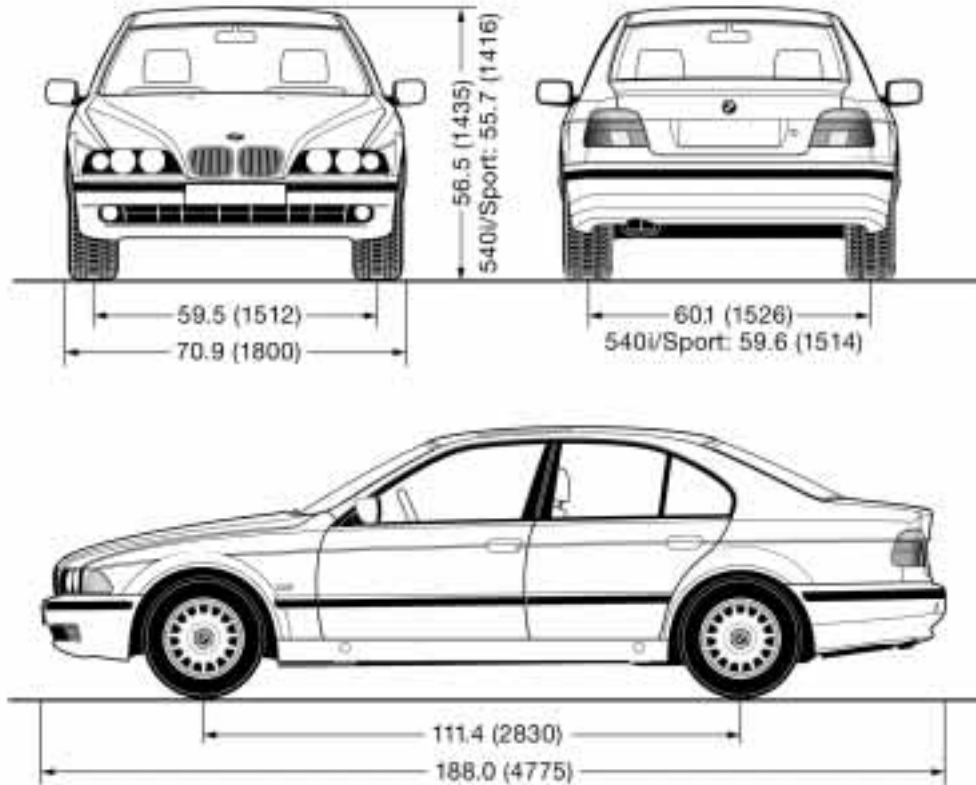

All dimensions are given in inches (mm).

Min. turning circle dia.: BMW 525i, 530i 37.1 ft (11.3 m), BMW 540i 37.4 ft (11.4 m)

220 Dimensions – sport wagon

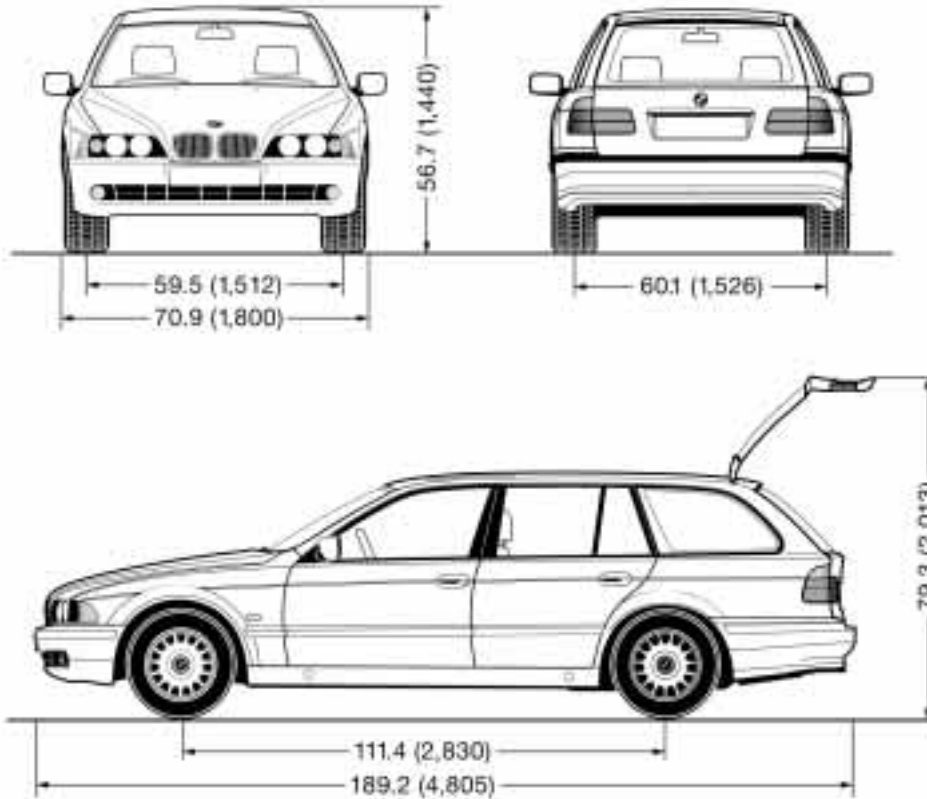

All dimensions are given in inches (mm). Height with roof-mounted luggage rack*: 57.4 (1,459)
Min. turning circle dia.: BMW 525i 37.1 ft (11.3 m), BMW 540i 37.4 ft (11.4 m)

Weights - sedan

		BMW 525i	BMW 530i	BMW 540i
Curb weight (with one person, ready for operation, full tank of fuel, options not included)				
with manual transmission	lbs. (kg)	3,450 (1,565)	3,494 (1,585)	3,748 (1,700)
with automatic transmission	lbs. (kg)	3,505 (1,590)	3,549 (1,610)	3,803 (1,725)
Approved gross vehicle weight				
with manual transmission	lbs. (kg)	4,464 (2,025)	4,509 (2,045)	4,762 (2,160)
with automatic transmission	lbs. (kg)	4,520 (2,050)	4,563 (2,070)	4,817 (2,185)
Approved front axle weight	lbs. (kg)	2,116 (960)	2,138 (970)	2,381 (1,080)
Approved rear axle weight	lbs. (kg)	2,579 (1,170)	2,579 (1,170)	2,635 (1,195)
Approved roof load capacity	lbs. (kg)	220 (100)	220 (100)	220 (100)
Approved axle loads and approved gross vehicle weight may not be exceeded.				
Luggage compartment capacity	cu ft (l)	16.2 (460)	16.2 (460)	16.2 (460)

222 **Weights – sport wagon**

		BMW 525i	BMW 540i
Curb weight (with one person, ready for operation, full tank of fuel, options not included)			
with manual transmission	lbs (kg)	3,682 (1,670)	–
with automatic transmission	lbs (kg)	3,736 (1,695)	4,056 (1,840)
Approved gross vehicle weight			
with manual transmission	lbs (kg)	4,773 (2,165)	–
with automatic transmission	lbs (kg)	4,828 (2,190)	5,093 (2,310)
Approved front axle weight	lbs (kg)	2,116 (960)	2,381 (1,080)
Approved rear axle weight	lbs (kg)	2,844 (1,290)	2,910 (1,320)
Approved roof load capacity	lbs (kg)	220 (100)	220 (100)
Approved axle loads and approved gross vehicle weight may not be exceeded.			
Luggage compartment capacity	cu ft (l)	14.5 – 53.9 (410 – 1,525)	14.5 – 53.9 (410 – 1,525)

			Notes
Fuel tank	gal. (liters)	approx. 18.5 (approx. 70)	Fuel specification: page 29
Reserve	gal. (liters)	approx. 2.0 (approx. 8) – BMW 525i, 530i	
		approx. 2.5 (approx. 10) – BMW 540i	
Windshield washer system	quarts (liters)	approx. 3.7 (approx. 3.5)	For details: page 164
with headlamp washer system	quarts (liters)	approx. 6.3 (approx 6.0)	
Intensive cleaning system	quarts (liters)	approx. 1.1 (approx 1.0)	
Cooling system including heater circuit	quarts (liters)	11.1 (10.5) – BMW 525i, 530i 12.7 (12.0) – BMW 540i	For details: page 167
Engine with oil filter change	quarts (liters)	6.9 (6.5) – BMW 525i, 530i 7.9 (7.5) – BMW 540i	"BMW High Performance Synthetic Oil." For details: page 167
Manual transmission, automatic transmission and differential	–	–	Lifetime fluid, no fluid change required

224 Electrical system

Battery

12 V, 90Ah

Spark plugs

Bosch FGR 7 DQP or
NGK BKR 6 EQUIP

This spark ignition system meets all requirements of the Canadian Interference-Causing Equipment Regulations (ICES-2).

Drive belts

BMW 525i, 530i:

Water pump – Generator –
Power steering
Drive belt 6 PK x 1538

A/C compressor
Drive belt 5 PK x 863

BMW 540i:

Water pump – Generator –
Power steering
V-belt 7 K x 1635
A/C compressor
V-belt 5 K x 1004



You can obtain Original BMW Parts and Accessories, as well as professional advice from your BMW center. ◀

ABC

ABC

Everything from A to Z [228](#)



Overview

Controls and features

Operation, care
and maintenance

Owner service procedures

Advanced technology

Technical data

Index

Overview

Controls

Car care

Repairs

Technology

Data

Index

Everything from A to Z

A

ABS (Antilock Brake System) [23](#), [143](#)
Accessories [6](#)
Activated-charcoal filter [119](#)
Active seat [55](#), [210](#)
Adaptive Transmission Control (ATC) [72](#), [207](#)
Add
antifreeze [168](#)
brake fluid [168](#)
engine coolant [168](#)
engine oil [165](#)
washer fluids [164](#)
Adjust washer nozzles [164](#)
Adjusting
backrest angle [53](#)
backrest, forward/backward [52](#)
seats [52](#)
steering wheel [56](#)
temperature [110](#), [116](#)
thigh support [55](#)
Air conditioner [108](#)
Air distribution [110](#), [116](#)
Air outlets [108](#), [114](#)
Air pressure [29](#), [150](#)
Air supply [110](#), [117](#)
Air vent [108](#), [114](#)

Airbags [23](#), [62](#), [176](#), [206](#)
Alarm system [47](#)
Antennas [149](#)
Antifreeze [167](#)
radiator [146](#)
Antilock Brake System (ABS) [23](#), [143](#)
Anti-theft alarm system [47](#)
Anti-theft protection [39](#)
Approved axle weight [221](#)
Approved gross vehicle weight [221](#)
Approved roof load capacity [221](#)
Aquaplaning [141](#), [150](#)
Arrival time [97](#)
ASC+T/DSC (Automatic Stability Control plus Traction/Dynamic Stability Control) [24](#), [102](#), [208](#)
Ashtray [126](#)
ATC (Adaptive Transmission Control) [72](#), [207](#)
Attach vacuum cleaner [127](#)
AUC (Automatic recirculated-air control) [117](#)
Automatic car washes [171](#)
Automatic climate control [114](#)
remove condensation from windows [117](#)

Automatic cruise control [81](#)
Automatic curb monitor [59](#)
Automatic dimming interior rearview mirror [57](#)
Automatic rear window cleaning [80](#)
Automatic recirculated-air control (AUC) [117](#)
Automatic Stability Control plus Traction/Dynamic Stability Control (ASC+T/DSC) [24](#), [102](#), [208](#)
Automatic transmission [72](#)
Automatic transmission with Steptronic [75](#)
Average fuel consumption [89](#)
Average speed [89](#), [98](#)
Avoid false alarms [48](#)
Axle loads [221](#)













B

Backrest, adjusting [52](#), [55](#)
Backup lamps [71](#)
bulb replacement [186](#)
Battery [193](#), [224](#)
capacity [224](#)
charge condition [194](#)
charging [194](#)
discharged [200](#)
removing and installing [195](#)

Belts [61](#)
Beverage holder [125](#)
Blower [110](#), [117](#)
BMW active seat [55](#), [210](#)
BMW comfort seat [54](#)
BMW sports seat [55](#)
BMW Universal Transmitter [121](#)
Body-cavity protectant [172](#)
Brake faults [146](#)
Brake hydraulic system [22](#), [146](#)
Brake lamps, bulb replacement [186](#)
Brake system [140](#)
brake faults [146](#)
brake fluid [168](#)
brake lamps, bulb replacement [186](#)
brake pads [23](#)
disc brakes [144](#)
parking brake [23](#), [70](#)
Brake-in procedure [140](#)
Break-resistant security glass [174](#)
care [174](#)
Bulb replacement [183](#)

C

California Proposition 65 Warning [177](#)
Capacity [223](#)

- Car jack [190](#)
 - Car keys [36](#)
 - Car Memory [60](#)
 - Car phones, refer to the separate Owner's Manual
 - Car radio reception [149](#)
 - Car telephone [125](#)
 - Car wash [171](#)
 - Care
 - vehicle exterior [172](#)
 - vehicle interior [174](#)
 - Cargo loading [136](#)
 - Caring for the vehicle
 - finish [173](#)
 - Catalytic converter [142](#)
 - Cellular phone [149](#)
 - Center (high-mount) brake lamp, bulb
 - replacement [187](#)
 - Central locking
 - system [38, 42](#)
 - Changing a tire [190](#)
 - Changing a wheel [190](#)
 - Charge indicator lamp [22](#)
 - Charging the battery [194](#)
 - Check air pressure [30](#)
 - Check button [86](#)
 - Check Control [86](#)
 - Check engine oil
 - level [165](#)
 - Check tire pressures [29](#)
 - Child restraint systems [62](#)
 - Child seat [62, 66](#)
 - Child seat security [67](#)
 - Child-safety locks [67](#)
 - Cigarette lighter [126](#)
 - Cleaning headlamps [79](#)
 - Cleaning windshield [78, 79](#)
 - Clock [92](#)
 - Clock, refer also to the onboard monitor
 - Cockpit [16](#)
 - Code [98](#)
 - activating [98](#)
 - de-activating [98](#)
 - selecting [98](#)
 - Cold start [69](#)
 - Combination switch [78](#)
 - Comfort seat [54](#)
 - Compartments [124](#)
 - Computer [89, 95](#)
 - average fuel consumption [89](#)
 - average speed [89](#)
 - cruising range [89](#)
 - outside temperature [89](#)
 - remote control [99](#)
 - Computer, refer also to the onboard monitor Owner's Manual
 - Configure settings [60](#)
 - Consumption display [84](#)
 - Consumption, fuel [97](#)
 - Contamination on paintwork [172](#)
 - Convenience operation
 - sliding/tilt sunroof [38](#)
 - windows [38](#)
 - Convenience starting
 - feature [69](#)
 - Coolant [146, 167](#)
 - antifreeze [146](#)
 - temperature gauge [85](#)
 - Copyright notice [4](#)
 - Courtesy lamp, bulb
 - replacement [189](#)
 - Cover, sun blinds [120](#)
 - Cruise control [81](#)
 - Cruising range [89, 97](#)
 - Cup holder [125](#)
 - Curb weight [221](#)
- ## D
- Dashboard [16](#)
 - Data link connector for Onboard Diagnostics [178](#)
 - Date
 - calling up [92](#)
 - changing [92](#)
 - Date, refer also to the onboard monitor Owner's Manual
 - Daytime-driving lamp [105](#)
 - DBC (Dynamic Brake Control) [23, 100, 145](#)
 - Deactivating [99](#)
 - interior motion sensor [40, 48](#)
 - tilt sensor alarm system [40, 48](#)
 - Deep water [141](#)
 - Defrost
 - rear window [80](#)
 - Defrost position [113, 117](#)
 - Defrost
 - windows [113, 117](#)
 - Difficult steering [148](#)
 - Digital clock [92](#)
 - Digital sound
 - processing [211](#)
 - Dimensions [219](#)
 - Dipstick, engine oil [165](#)
 - Disc brakes [144](#)
 - Disconnect the battery [195](#)
 - Displacement [218](#)
 - Display lighting [105](#)
 - Displays [18, 20](#)
 - Distance [96](#)
 - Distance warning [100](#)
 - Diversity Antenna system [209](#)
 - Divided rear-seat backrest [128](#)
 - Door keys [36](#)

Everything from A to Z

Door locks, care 146

Doors

emergency release 38

manual operation 38

remote control 40

unlocking and locking 38

DOT Quality Grades 151

Drive belts 224

Driving in winter 146

Driving notes 141

Driving through water 141

DSC (Dynamic Stability Control) 24, 102, 208

DSP sound system 211
refer also to the Radio
Owner's Manual

Dynamic Brake Control
(DBC) 23, 100, 145

Dynamic Stability Control
(DSC) 24, 102, 208

E

Electric power seat 52

Electric power windows 49

Electrical defect

fuel filler door 198

sliding/tilt sunroof 198

tailgate 199

Electrical heating, exterior
mirror 57

Electrical steering wheel,
adjusting 56

Electrical system 224

Electronic vehicle

immobilizer 37

Elements of operation 16

Emergency operation

doors 38

fuel filler door 198

luggage compartment lid/
tailgate 43, 199

sliding/tilt sunroof 198

Energy control 84

Engine

compartment 160

coolant 167

Engine oil

consumption 165

grades 166

level 23

pressure 22

specifications 166

Engine specifications 218

Error indicators 86

Estimated time of arrival 97

Exterior finish 172

Exterior mirror 56

electrical heating 57

Exterior mirror with
automatic dimming
feature 211

F

Failure messages 86

Failure of an electrical
accessory 196

Failure warnings 86

Filler cap cover 28

Filling capacities 223

Filling the washer

reservoir 164

First-aid kit 27

Fittings, tow-starting and
towing 201

Flashlight 124

Flat tire 150, 190

Fog lamp, bulb

replacement 185

Footbrake 144

Footwell lamps 107

bulb replacement 189

Forward/backward

adjustment, seats 52, 55

Front fog lamps 106

Front seat adjustment 52

Frost protection,
radiator 167

Fuel 29

gauge 84

quality 29

tank capacity 223

Fuel consumption 97

average 97

indicator 84

Fuel filler door, release after
electrical fault 198

Fuses 196, 197

G

Gasoline 29

gauge 84

quality 29

Glove compartment 124

bulb replacement 189

Gross vehicle weight 221

H

Handbrake 23, 70

Hands-free system 125

Hazard warning
flashers 27

Hazard warning
triangle 27

Head restraints 53

Headlamp covers,
care 171, 183

Headlamp flasher 78

Headlamp washer
system 164

Heated seats 119

Heated steering wheel 120

Heating and

ventilation 108, 114

Heating while stopped 118

Heating, rapid 113

Heavy loads 136

Everything from A to Z

Height 219
 Height adjustment
 seats 52
 steering wheel 56
 Help with jump
 starting 200🔧
 HiFi system 211
 High beams 24
 bulb replacement 183🔧
 High Performance Synthetic
 Oils 166
 High-mount brake lamp 187
 Hood release 159🔧
 Horn 25
 Hydraulic Brake Assistant,
 refer to DBC 23, 100, 145

I

Ice warning 83
 Identification number of the
 vehicle 169
 Identification, tires 153
 Ignition key 36
 Ignition lock 68
 Imprint 4
 Independent
 ventilation 94, 120
 Independent ventilation,
 refer also to the onboard
 monitor Owner's Manual
 Indicator lamps 22🔧

Inflation
 pressure 29🔧, 30, 150
 monitoring 103, 213
 INSPECTION 85
 Instrument cluster 18, 20
 Instrument lighting 105
 Instrument panel 20
 Instrument panel switch 78
 Instruments 18
 Integrated rear
 suspension 214
 Intensive
 cleaning 78, 79, 164
 Interaxle tire rotation 152
 Interference indicators 86
 Interference with
 car phones 149
 Interior lamps 106
 bulb replacement 188🔧
 remote control 40
 Interior mirror 57
 with automatic dimming
 feature 211
 Interior motion sensor 48
 deactivation 48
 Interior rearview mirror
 with automatic dimming
 feature 57
 Interlock 68
 Intermittent mode 78

J

Jack 190🔧
 Jump starting 200🔧

K

Key Memory 60
 Key, transmitter 36
 Keys 36
 Keys with remote control 36
 Kickdown 73, 76

L





Lashing eye 136
 Leather care 175
 Length 219
 Level control
 system 23, 214
 inactive 148🔧
 License plate lamps, bulb
 replacement 188🔧
 Light switch 105
 Light-alloy wheels 156
 Lighter 126
 Lights-on warning 105
 LIMIT 95
 Load-securing devices 136
 Locking and unlocking the
 doors 38
 Louvers 108, 114
 Low beams 105
 bulb replacement 183🔧

Low-fuel warning lamp 84
 Lug bolts 191
 Lug wrench 191🔧
 Luggage compartment 46
 capacity 221
 hanger 46
 lamps 106
 Luggage compartment
 lamps, bulb
 replacement 189🔧
 Luggage compartment lid/
 tailgate 43
 emergency actuation 43
 opening separately 43
 remote control 41
 secure separately 43
 unlock in case of electrical
 fault 43🔧
 Luggage space 46
 Luggage straps 46
 Lumbar support 54

M

M+S tires 154
 Magic Eye 194
 Maintenance 85🔧, 170🔧
 Malfunction displays 86🔧

Everything from A to Z

Manual operation
doors 38 
fuel filler door 198 
luggage compartment lid/
tailgate 43, 199
sliding/tilt sunroof 198 
tailgate 199 

Manual transmission 70
Manually controlled
recirculated-air 117

Master key 36

Mechanical seat 53

Memo 93

Memory 58

MFL (Multifunction steering
wheel) 25

Microfilter 112, 119

MID (Multi-Information
Display) 91
computer 95
digital clock 92

Mirror 56

heating 57

memory 58

Mirrors with automatic
dimming feature 211

Mobile communication
systems, refer to the
separate Owner's Manual

Mobile phones 149

Modifications,
technical 6, 177

Moonroof 51

Multifunction steering wheel
(MFL) 25

Multi-Information Display
(MID) 91

N

Neck rest 53

Nonsmoker equipment 126

Nozzles 114

O

OBD connector 178

OBD interface socket 178

Odometer 83

Oil

additives 165

consumption 165

grades 166

Oil change interval, refer to
the Service and Warranty
Information Booklet (US
models) or to the Warranty
and Service Guide Booklet
(Canadian models)

Oil dipstick 165

Oil level, indicator lamp 23

Oil pressure, indicator
lamp 23

Oil specifications 166 

OILSERVICE 85

Old batteries 195

Onboard computer, refer
also to computer

Onboard monitor, refer also
to the separate Owner's
Manual

Onboard tool kit 182 

Opening and closing
from the inside 42
from the outside 38

Operating range 89

Outlets, ventilation 108, 114

Outside temperature 89
display 83

P

Paint

blemishes 172

care 172

minor repairs 173

waxing 173

Paintwork, refer to paint

Park Distance Control
(PDC) 100

Parking 184

Parking brake 23, 70

Parking help 100

Parking lamp, bulb
replacement 184 

Parking lamps 106

Parking, winter 148

PDC (Park Distance
Control) 100

Playing cassettes, refer to
the Radio Owner's Manual

Playing CDs, refer to the
Radio Owner's Manual

Pocket light 124

Pollen 112

Pollen filter 119

Power 51

Power steering 148

Power windows 49
safety switch 50

Power-slip control, refer to
ASC+T/DSC 102

Pressure, tire 30, 150

monitoring 103, 213

Pressure, tires 29 , 150 

R

Radio 149
refer also to the separate
Owner's Manual

Radio reception 149, 209

Rain sensor 78, 171, 212

RDC (Tire Pressure
Control) 103, 213

Reading lamps 107

Rear window blind 120

Rear window
defroster 80, 110, 118

Rear window wiper 80

Rear wiper blade, blade replacement [182](#)[🔧]
 Rear-seat backrest, removable [128](#)
 Rearview mirror [57](#)
 Recirculated air mode [110](#)
 Recirculated-air control [117](#)
 Reclining seat [52](#)
 Refueling [28](#)
 Releasing fuel filler door after electrical defect [198](#)[🔧]
 Releasing the hood [159](#)[🔧]
 Reminder signal [93](#)
 Remote control [39](#)
 computer [99](#)
 Removable rear-seat backrest [128](#)
 Removing condensation from the windows [113](#)[🔧], [117](#)[🔧]
 from the windshield [113](#)[🔧], [117](#)[🔧]
 Replace wiper blades [182](#)[🔧]
 Replacement keys [36](#)
 Replacement of tires [151](#)
 Replacing fuses [196](#)[🔧]
 Reporting safety defects [7](#)
 Reservoir, washer fluids [164](#)[🔧]
 Residual heat [118](#)
 Restraint system [62](#)

Reverse [71](#)
 Rims [153](#)
 Roller sun blind [120](#)
 Roof load capacity [221](#)
 Roof-mounted luggage rack [137](#)
 Rubber parts [147](#)







S

Safety belt tensioner [210](#)
 Safety belts [61](#)
 Safety lock buttons [42](#)
 Seats
 electric power [52](#)
 forward/backward adjustment [52](#), [55](#)
 heating [119](#)
 height adjustment [52](#)
 mechanical [53](#)
 memory [58](#)
 Secure the load [46](#), [136](#)
 Selector lever, automatic transmission [72](#), [75](#)
 Self-dimming rearview mirror [211](#)
 Service and Warranty Information Booklet (US models) [170](#)
 Service Interval Display [85](#), [170](#)
 Servotronic [148](#)

Shift lever [70](#)
 Shiftlock [72](#), [75](#)
 Shoulder support [54](#)
 Shutting off the engine [69](#)
 Side airbags [62](#)
 Side Impact Head Protection System [62](#)
 Side lamps, bulb replacement [184](#)[🔧]
 Ski bag [129](#)
 Ski bag in the sport wagon [131](#)
 Skid control [148](#)
 Sliding [148](#)
 Sliding/tilt sunroof [50](#)
 closing after an after an electrical defect [198](#)[🔧]
 convenience operation [38](#)
 glass moonroof [51](#)
 manual operation [198](#)
 power supply interruption [51](#)[🔧]
 remote control [40](#)
 Slippery roads [147](#)
 Snow chains [147](#), [155](#)[🔧]
 Socket [127](#)
 Sound system, refer to DSP [211](#)
 Spare key [36](#)
 Spare tire [191](#)[🔧]
 Spark plugs [224](#)
 Speaker [125](#)



Special oil [166](#)[🔧]
 Specifications for engine oil [166](#)
 Speed [98](#)
 Speed control [81](#)
 Speed limit [95](#), [96](#)
 Speedometer [18](#), [20](#)
 Sport wagon
 compartments in the luggage compartment [133](#)
 folding down the rear backrest [132](#)
 lashing eyes [136](#)
 load-securing devices [136](#)
 luggage compartment [132](#)
 luggage compartment lamps, bulb replacement [189](#)[🔧]
 opening the rear window [44](#)
 partition net [132](#)
 rear window wiper [80](#)
 rear window wiper, blade replacement [182](#)[🔧]
 releasing the fuel filler door after an electrical defect [198](#)[🔧]
 releasing the tailgate after an electrical defect [199](#)[🔧]

Everything from A to Z







roll-up cover 132
securing a load 136
ski bag 131
tail lamp assembly, bulb replacement 186 
tailgate, manual release after electrical fault 198 
Sports seat 55
Sports steering wheel 26
Start the engine 69
Starting 69
Starting assistance 200 
Starting help 200
Starting off 147
Starting problems 69, 142 , 200 
Starting the engine 68 
Steel wheel 158
Steering 148
Steering wheel adjustment 56
heating 120
lock 68
memory 58
Steptronic 75
Stopwatch 93
Storage 124
Summer tires 153
Sun blind cover 120
Sun visors 57

Sunroof 50
with glass moonroof 51
Switching off the engine 69
Switch-on times input 94
Symbols 4

T

Tachometer 84
Tail lamp assembly, bulb replacement 186 
Tail lamps 186
Tailgate 199
convenience opening mode 40
manual release after electrical fault 199
refer also to luggage compartment
release after an electrical defect 199 
Tank capacity 223
Technical modifications 6, 177
Telephone hookup 125
Temperature display, engine coolant 85
Temperature display, outside temperature 83
Temperature gauge 85
Temperature layering 111, 119

Tensioning straps 46
Thigh support adjustment 55
Third brake lamp, bulb replacement 187 
Through-loading system 128
Tilt alarm 40
Tilt alarm sensor 48
deactivation 48
Tilt function
passenger side exterior mirror 59
steering wheel 56
Time
calling up 92
changing 92
of arrival, estimated 97
Tire
change 190
code 153
damage 150
inflation pressure 30, 150
monitoring inflation pressure 103, 213
renewal 151
rotation between axles 151
tread 150
valve caps 154
wear indicator 150

Tire Pressure Control (RDC) 103, 213
Tire, changing 190 
Tools 182 
Torque 218
Tow fittings 201 
Towing 201 
Tow-starting 201 
Track width 219
Traction control system, refer to ASC+T/DSC
Transmission 70, 75
Transmitter key 36
Transporting children safely 66
Tread depth indicators 150
Tread depth, tires 150
Tread wear indicator 150
Trip odometer 83
Trunk, refer to luggage compartment
Turn signal indicator 78
bulb replacement 184 , 186 
Turning circle 219

U

Uniform Tire Quality Grading (UTQR) 152
Universal Transmitter 121
Use antifreeze 167 

Everything from A to Z



Used batteries 195
Used oil, disposal 167



V

Valve caps 154
Vanity mirror 57
Vehicle battery 193
Vehicle care
 exterior 172
 interior 174
Vehicle Identification
 Number 169
Vehicle immobilizer 37
Vehicle painting 172
Vehicle removal from
 service 176
Vehicle storage 176
Ventilation 108, 112, 114
 draft-free 111, 118
 in the rear 111, 119
 while parked 120
Vinyl upholstery, care 174
Viscosity 166
Voice recognition 26
 refer also to the Radio
 Owner's Manual

W

Warm feet – cool
 head 111, 119
Warning lamp "Please fasten
 safety belts" 23

Warning lamps 22 
Warning messages 86 
Warning triangle 27 
Warranty and Service Guide
 Booklet (Canadian
 models) 170

Washer fluid reservoir,
 filling 164
Washer nozzles 164
Washing your car 171
Water on the roads 141
Waxing, paintwork 173
Wear indicator in the
 tires 150
Weight 221
Wheel, changing 190 
Wheelbase 219
Wheels and tires 153, 156
Width 219
Windows
 convenience operation 38
 remote control 40
Windshield washer nozzle
 adjustment 164
Windshield washer reservoir,
 filling 164
Windshield wipers 78
Winter driving 146
Winter operation 146
Winter tires 154
Wiper blade
 replacement 182 

Wiper/Washer system 78
Work in the engine
 compartment 159 

X

Xenon lamps 105, 184, 215

Refueling

BMW recommends Castrol



So that you will have important specifications available when you stop to refuel, we recommend that you supplement this table with data which apply to your vehicle.

Fuel

Designation	Premium Unleaded Gasoline
AKI: minimum	91

Engine oil

Quality	
---------	--

The space between the two marks on the dipstick corresponds to approx. 1.1 US quarts (1 liter).

Tire inflation pressures	Summer		Winter	
	front	rear	front	rear
4 persons				
5 persons or 4 plus luggage				

**We wish you an enjoyable
driving experience.**



The Ultimate Driving Machine

