



M5

Congratulations, and thank you for choosing a BMW.

Thorough familiarity with your vehicle will provide you with enhanced control and security when you drive it. We therefore have this request:

Please take the time to read this Owner's Manual and familiarize yourself with the information that we have compiled for you before starting off in your new BMW. The manual contains important data and instructions intended to assist you in obtaining maximum satisfaction from your BMW's unique array of advanced technical features. It also contains information on vehicle maintenance designed to enhance operating safety while simultaneously helping you to maintain your BMW's value throughout an extended service life. For additional information refer to the supplemental manuals.

This Owner's Manual should be considered a permanent part of this vehicle. It should stay with the vehicle when sold to provide the next owner with important operating, safety and maintenance information.

We wish you an enjoyable driving experience.

BMW M

Contents

Notes	About this Owner's Manual	8
	Symbols used	8
	Your individual vehicle	8
	Status at time of printing	9
	For your own safety	9
	Symbol on vehicle parts	10
	Service and Warranty	10
	Reporting safety defects	10

Overview	Cockpit	14
	Instrument cluster	15
	Indicator and warning lamps	16
	Steering wheel with multifunction buttons	19
	Warning triangle	20
	First-aid kit	20
	Refueling	20
	Fuel specifications	22
Tire inflation pressure	22	

Controls and features	Opening and closing:	
	Keys	26
	Central locking system	26
	Opening and closing – via the door lock	27
	Opening and closing – via the remote control	28
	Opening and closing – from the inside	31
	Luggage compartment lid	32
	Luggage compartment	34
	Alarm system	35
	Electric power windows	36
Sliding/tilt sunroof	38	

Adjustments:

Sitting safely	40
Seats	40
BMW M sport seat	41
BMW comfort seat	42
Head restraints	43
BMW active seat	43
Safety belts	44
Seat, mirror and steering wheel memory	45
Seat heating	46
Steering wheel	47
Mirrors	48

- Controls and features**
- Passenger safety systems:**
 - Airbags 49
 - Transporting children safely 51
 - Vehicle Memory, Key Memory 55
 - Driving:**
 - Steering/Ignition lock 56
 - Starting the engine 56
 - Switching off the engine 57
 - Parking brake 58
 - Manual transmission 58
 - Turn signal/Headlamp flasher 59
 - Washer/Wiper system/
 - Rain sensor 60
 - Cruise control 61
 - Everything under control:**
 - Odometer, outside temperature display 63
 - Tachometer 64
 - Engine oil temperature 64
 - Fuel gauge 64
 - Coolant temperature gauge 65
 - Service Interval Display 65
 - Check Control 66
 - Multi-Information Display (MID) 69
 - Digital clock 70
 - Computer 73
 - Technology for safety and driving convenience:**
 - Park Distance Control (PDC) 78
 - Dynamic Stability Control (DSC) 80
 - M Dynamic Driving Control 81
 - Flat Tire Monitor 82
 - Lamps:**
 - Parking lamps/Low beams 84
 - Instrument lighting 85
 - High beams/Standing lamps 85
 - Fog lamps 85
 - Interior lamps 86
 - Reading lamps 86
 - Controlling the climate for pleasant driving:**
 - Automatic climate control 87
 - Roller sun blind 92
 - Parked-car ventilation 92
 - Interior conveniences:**
 - BMW Universal Transmitter 93
 - Glove compartment 96
 - Storage compartments 96
 - Cellular phone 97
 - Beverage holder 97
 - Ashtray, front 97
 - Cigarette lighter 98
 - Ashtray, rear 98
 - Loading and transporting cargo:**
 - Through-loading system 99
 - Ski bag 100
 - Cargo loading 102
 - Roof-mounted luggage rack 103

Contents

Operation, maintenance

Special operating instructions:

- Break-in procedures 106
- Driving notes 107
- Antilock Brake System 107
- Brake system 108

Wheels and tires:

- Tire inflation pressure 109
- Tire condition 109
- Tire replacement 110
- Wheel and tire combinations 111
- Special characteristics of winter tires 112
- Snow chains 112

In the engine compartment:

- Hood 113
- Engine compartment essentials 114
- Washer fluids 115
- Engine oil 115
- Coolant 117
- Brake fluid 118

Maintenance:

- The BMW Maintenance System 119

Laws and regulations:

- Technical modifications 120
- California Proposition 65 Warning 120
- OBD interface socket 121

Owner service procedures

Replacement procedures:

- Onboard tool kit 124
- Windshield wiper blades 124
- Lamps and bulbs 124
- Repairing a flat tire 128
- Battery 131
- Fuses 132

Assistance, giving and receiving:

- Jump-starting 133
- Towing the vehicle 135

Technical data

- Engine data [140](#)
- Dimensions [141](#)
- Weights [142](#)
- Capacities [143](#)

Index

- Everything from A to Z [146](#)

8 Notes

About this Owner's Manual

We have made every effort to ensure that you are able to find what you need in this Owner's Manual as quickly as possible. The fastest way to find certain topics is by using the detailed index at the end. If you are looking for a brief initial summary of the essentials, please turn to the first chapter.

Should you wish to sell your BMW at some time in the future, please remember to hand over this Owner's Manual to the new owner; it is an important part of the vehicle.

If you have any questions, your BMW center will be glad to advise you.

Symbols used



Indicates precautions that must be followed precisely in order to avoid the possibility of personal injury and serious damage to the vehicle.



Contains information that will assist you in gaining the optimum benefit from your vehicle and enable you to care more effectively for your vehicle.



Refers to measures that can be taken to help protect the environment.

◀ Marks the end of a specific item of information.

* Indicates special equipment, country-specific equipment and optional extras.



Identifies index entries that refer to owner service procedures or topics on vehicle maintenance.



Identifies systems or components, which can be activated or adapted to suit an individual driver's requirements ("Vehicle Memory", "Key Memory"). Refer to page 55. Activation and adjustments on some of these systems can be performed at your BMW center.

Your individual vehicle

On buying your BMW, you have decided in favor of a model with individualized equipment and features. This Owner's Manual describes all models and equipment that BMW offers within the same group.

We hope you will understand that equipment and features are included which you might not have chosen for your vehicle. You can easily identify any differences with the aid of the asterisk * used to identify all optional equipment and accessories.

If your BMW features equipment which is not described in this Owner's Manual, Supplementary Owner's Manuals are enclosed. We ask you to read these manuals as well.

Notes

Status at time of printing

BMW pursues a policy of continuous, ongoing development designed to ensure that our vehicles continue to embody the highest quality and safety standards combined with advanced, state-of-the-art technology. For this reason, it is possible that the features described in this Owner's Manual could differ from those on your vehicle. Nor can errors and omissions be entirely ruled out. We therefore request your understanding for the fact that we are unable to recognize any legal claims based on the data, illustrations or descriptions in this manual.

For your own safety



Use unleaded gasoline only. Fuels containing up to and including 10 % ethanol or other oxygenates with up to 2.8 % oxygen by weight – i.e. 15 % MTBE or 3 % methanol plus an equivalent amount of co-solvent – will not void the applicable warranties covering defects in materials or workmanship. Field experience has indicated significant differences in fuel quality – volatility, composition, additives, etc. among gasolines offered for sale in the United States and Canada. The use of poor-quality fuels may result in driveability, starting and stalling problems, especially under certain environmental conditions, such as high ambient temperature and high altitude. Should you encounter driveability problems that you suspect could be related to the fuel you are using, we recommend that you respond by switching to a recognized high-quality brand. Failure to comply with these recommendations may result in unscheduled maintenance. Obey pertinent safety rules when you are handling gasoline. ◀



Important safety information! For your own safety, use genuine parts and accessories approved by BMW. When you purchase accessories tested and approved by BMW and Original BMW Parts, you simultaneously acquire the assurance that they have been thoroughly tested by BMW to ensure optimum performance when installed on your vehicle. BMW warrants these parts to be free from defects in material and workmanship. BMW will not accept any liability for damages resulting from installation of parts and accessories not approved by BMW. BMW cannot test every product from other manufacturers to verify if it can be used on a BMW safely and without risk to either the vehicle, its operation, or its occupants. Original BMW Parts, BMW Accessories and other products approved by BMW, together with professional advice on using these items, are available from all BMW centers.

Installation and operation of non-BMW approved accessories such as alarms, radios, amplifiers, radar detectors, wheels, suspension components, brake dust shields, telephones – including operation of any portable cellular phone from within the vehicle without using an externally-mounted antenna – or transceiver equipment, e.g., CBs, walkie-talkie, ham radio or similar accessories, may cause extensive damage to the vehicle, compromise its safety, interfere with the vehicle's electrical system, or affect the validity of the BMW Limited Warranty. See your BMW center for additional information. ◀



Maintenance, replacement, or repair of the emission control devices and systems may be performed by any automotive repair establishment or individual using any certified automotive part. ◀

Symbol on vehicle parts



Indicates that you should consult the relevant section of this Owner's Manual for information on a particular part or assembly.

Service and Warranty

This manual is supplemented by a Service and Warranty Information Booklet for US models or a Warranty and Service Guide Booklet for Canadian models.

We recommend that you read this publication thoroughly.

Your BMW is covered by the following warranties:

- ▷ New Vehicle Limited Warranty
- ▷ Rust Perforation Limited Warranty
- ▷ Federal Emissions System Defect Warranty
- ▷ Federal Emissions Performance Warranty
- ▷ California Emissions Control System Limited Warranty

Detailed information about these warranties is listed in the Service and Warranty Information Booklet for US models or in the Warranty and Service Guide Booklet for Canadian models.

Reporting safety defects

The following only applies to vehicles owned and operated in the US.

If you believe that your vehicle has a defect which could cause a crash or could cause injury or death, you should immediately inform the National Highway Traffic Safety Administration NHTSA in addition to notifying BMW of North America, LLC, P.O. Box 1227, Westwood, New Jersey 07675-1227, Telephone (800) 831-1117.

If NHTSA receives similar complaints, it may open an investigation, and if it finds that a safety defect exists in a group of vehicles, it may order a recall and remedy campaign. However, NHTSA cannot become involved in individual problems between you, your dealer, or BMW of North America, LLC.

To contact NHTSA, you may either call the Auto Safety Hotline toll-free at 1-800-424-9393 – or 366-0123 in Washington, DC area – or write to: NHTSA, U.S. Department of Transportation, Washington, D.C. 20590. You can also obtain other information about motor vehicle safety from the Hotline.



Overview

Controls and features

Operation, maintenance

Owner service procedures

Technical data

Index



14 Cockpit

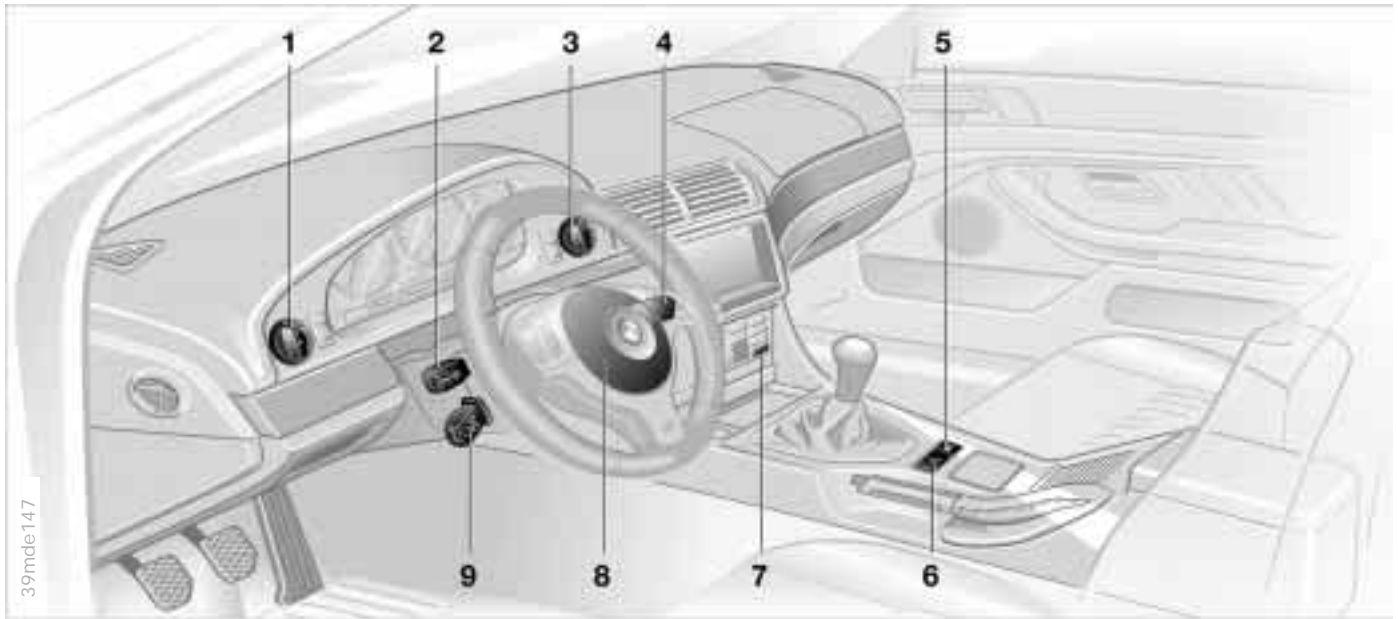

1 Parking lamps/Low beams [84](#)

2 ▷ Turn signal indicators [59](#)

▷ Standing lamps [85](#)

▷ High beams [85](#)

▷ Headlamp flasher [59](#)

▷ Computer [77](#)

3 Fog lamps [85](#)

4 Wiper/Washer system [60](#)

5 Central locking system [26](#)

6 Hazard warning flashers

7 Rear window defroster [90](#)

8 Horn: the entire surface

9 Adjusting the steering wheel [47](#)



- | | | |
|--|--|---|
| 1 Fuel gauge 64 | 7 Indicator and warning lamps 16 | 12 Check Control display 66 |
| 2 Indicator lamp for turn signal indicator 18 | 8 CHECK button 66 | 13 Odometer 63 |
| 3 Speedometer | 9 Outside temperature display 63 | 14 Service Interval Display 65 |
| 4 Indicator lamp for high beams 18 | 10 Indicator lamp for Dynamic Stability Control (DSC) 17 | 15 Trip odometer, reset to zero 63 |
| 5 Tachometer and engine oil temperature gauge 64 | 11 Trip odometer 63 | 16 Indicator and warning lamps 16 to 18 |
| 6 Coolant temperature gauge 65 | | |

16 Indicator and warning lamps

Technology that monitors itself

The system runs a check on the warning and indicator lamps marked by "●" each time you switch on the ignition. They each light up once for different periods of time.

If a fault should occur in one of these systems, the corresponding lamp does not go out after the engine is started or it lights up while the vehicle is moving. The following section describes how you should respond.

Red: stop immediately



●
Alternator charge current
The battery is no longer being charged. Indicates a defective alternator drive belt or a problem with the alternator's charge circuit. Please contact the nearest BMW center.



You should never attempt to continue driving with a defective drive belt, as the engine could overheat and sustain serious damage. A defective drive belt will also make the vehicle harder to steer. ◀



●
Engine oil pressure
May be accompanied by the warning "STOP!ENGINE OIL-PRESS" in the Check Control display panel: stop the vehicle immediately and switch off the engine. Check level of oil in engine, top up as required. If oil level is correct: please contact the nearest BMW center.



Do not continue driving, as the engine could sustain serious damage from inadequate lubrication. ◀



●
Brake hydraulic system
Have the brake fluid level checked. Before driving further, be sure to read the notes on pages 108 and 118.

The indicator lamp comes on together with the "CHECK BRAKE LININGS" message in the Check Control.



Brake hydraulic system warning lamp for Canadian models.

Indicator and warning lamps

Red: an important reminder



Parking brake ●
Comes on when you engage the parking brake.

For additional information: refer to page [58](#)



Parking brake warning lamp for Canadian models.



Please fasten safety belts ●
An acoustic signal sounds and a message appears in the Check Control for 4 to 8 seconds. The acoustic signal remains on until the belt is fastened.

For additional information on safety belts: refer to page [44](#)



Airbags ●
Please have the system inspected at your BMW center.

For additional information: refer to page [49](#)

Yellow: please have checked at your earliest opportunity



Antilock Brake System (ABS) ●
ABS has been deactivated in response to a system malfunction. Conventional braking efficiency is available and unrestricted. Please have the system inspected at your BMW center. For additional information: refer to page [107](#)



ABS warning lamp for Canadian models.



Dynamic Stability Control (DSC) ●
DSC has been switched off or has been deactivated because of a malfunction. In the event of a malfunction, have the system checked at your BMW center. For additional information: refer to page [80](#)



Dynamic Brake Control (DBC) ●
Malfunction in DBC system. Conventional braking performance remains available with no loss of efficiency.

Have the system repaired by your BMW center at the earliest possible opportunity.

For additional information: refer to page [80](#)



Dynamic Brake Control (DBC) warning lamp for Canadian models.



Service Engine Soon ●
If the indicator lamp lights up either continuously or intermittently, this indicates a fault in the emissions-related electronic systems. Although the vehicle remains operational, you should have the systems checked at your BMW center at the earliest possible opportunity. For additional information: refer to OBD interface socket, page [121](#)



Service Engine Soon warning lamp for Canadian models.

18 Indicator and warning lamps

Green: for your information



Turn signal indicators

Flashes when the turn signal indicators are on. Rapid flashing: indicates a system malfunction.

For additional information: refer to page [59](#)



Cruise control

Lights up when system is on: available for operation via the multifunction steering wheel.

For additional information: refer to page [61](#)



Front fog lamps

Lights up whenever you switch on the front fog lamps.

For additional information: refer to page [85](#)

Blue: for your information



High beams

Lights up when the high beams are on as well as when the headlamp flasher is activated.

For additional information: refer to pages [59](#), [85](#)

Steering wheel with multifunction buttons

The controls integrated within the multifunction steering wheel (MFL) have been designed to allow you to operate a number of accessories both quickly and safely, without taking your eyes from the road:

- ▷ Selected control functions for the radio along with CD and cassette player
- ▷ the cruise control
- ▷ selected telephone functions* and
- ▷ voice entry*.

 The controls are active only when the corresponding systems and accessories are switched on. ◀



Press briefly:
Receive a phone call, initiate dialing, terminate a call.
Extended pressure:
Activate/deactivate voice entry.



Switch between phone and radio, cassette and CD.



Forward:

- ▷ Radio
Press briefly: station scan in FM band
Extended pressure: search function
- ▷ CD
Press briefly: track scan
Extended pressure: search function in track
- ▷ Cassette
Press briefly: stop track scan or fast forward
Extended pressure: fast forward
- ▷ Phone
Scan personal phone book.



Reverse: functions as forward.



Volume



Cruise control: select a stored setting.



Cruise control: store and accelerate (+) or decelerate and store (-).



Cruise control: activate/interrupt/deactivate.

20 Warning triangle*

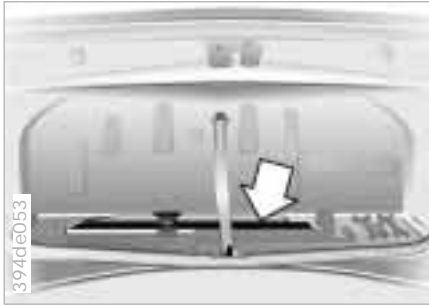

The hazard warning triangle is readily accessible. It is stored in the container for the onboard tool kit mounted in the luggage compartment lid.

To open the container, loosen the wingnut(s).

 Always observe all legal regulations requiring a warning triangle to be carried in the vehicle. ◀

First-aid kit*



Under the front passenger's seat.

To remove: lift the button on the front (arrow) and pull the first-aid kit forward out of its support.

To store: position the first-aid kit in the support, then push back until the button engages.

 Some of the articles contained in the first-aid kit have a limited storage life and should be replaced at periodic intervals. Please check the expiration dates of each of the items regularly, and replace any whose expiration dates have passed. You can acquire replacements in any drugstore or pharmacy.
Always observe all legal regulations requiring a first-aid kit to be carried in the vehicle. ◀

Refueling

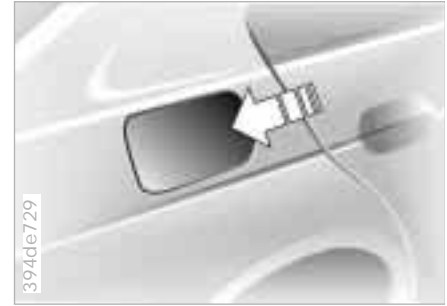

Fuel filler door

 Before filling the tank, shut off the engine. If you do not, fuel cannot be filled into the tank and the Service Engine Soon lamp may come on. ◀

To open the filler door, press its front edge.

If an electrical malfunction occurs, you can unlock the fuel filler door manually:

1. Use the handle to lower the trim panel on the right side of the luggage compartment
2. Pull the button with the fuel pump symbol.

Refueling

 Always observe all safety notices posted at the service station when refueling. Never carry spare fuel containers in your vehicle. Whether empty or full, these containers can leak, cause an explosion, or lead to fire in the event of a collision. ◀



Simple and environmentally friendly

 Open the fuel filler cap carefully to prevent fuel from spraying out. Fuel spray may cause injury. Do not attempt to continue adding fuel to the last drop, as this practice can cause fuel to spill. ◀

Keep the fuel filler cap in the bracket attached to the fuel filler door.

When refueling, insert the filler nozzle completely into the filler pipe. Pulling the nozzle out of the pipe during refueling

- ▷ results in premature pump shutoff
- ▷ and will reduce the effect of the vapor recovery system on the pump.

As long as the filler nozzle is used properly, the fuel tank is full whenever the nozzle shuts off the first time.

 Refill early to avoid damaging the catalytic converter; never attempt to drive to the last drop of fuel in the tank. ◀

Tank capacity: approx. 18.5 gal. (70 liters), with reserve of approx. 2.5 gal. (10 liters).

 Close the fuel filler cap carefully after refueling until a click is heard. While closing, be sure not to squeeze the strap which is fastened to the cap. A loose or missing cap will activate the message "CHECK FILLER CAP" in the Check Control. ◀

22 Fuel specifications

The engine uses lead-free gasoline only.

Required fuel:

- ▷ Premium Unleaded Gasoline, min. 91 AKI.
AKI = Anti Knock Index

 Never use leaded fuel, as it would cause permanent and irreparable damage to both the oxygen sensor and the catalytic converter. ◀

Tire inflation pressure



The inflation pressures are indicated on a warning sticker attached to the B-pillar behind the driver's door (visible with door open).

Check tire pressures

All pressure specifications are indicated in psi (kilopascal) for tires at ambient temperature (refer also to the next page).

 After correcting the inflation pressures in the tires, reactivate the Flat Tire Monitor, refer to page [82](#). ◀

 Check tire inflation pressures on a regular basis, at least every two weeks, and before every extended journey. Otherwise, incorrect tire pressure can lead to driving instability, tire damage and accidents. ◀

Comply with tire approval specifications

The inflation pressures in the table apply to BMW approved tire sizes and tire manufacturers. Your BMW center is familiar with these pressures. Higher pressures may be specified for tires made by other manufacturers.

Your vehicle is equipped with tires which not only meet US standards, but also European standards. We recommend the exclusive use of BMW approved tires.

Tire inflation pressure

BMW Tires					
All pressure specifications in the table are indicated in psi (kilopascal) with cold tires (cold = ambient temperature)					
	245/40 ZR 18	35 (240)	-	44 (300)	-
M5	275/35 ZR 18	-	38 (260)	-	48 (330)
	235/45 R 17 94 H M+S	35 (240)	38 (260)	39 (270)	46 (320)



Overview

Controls and features

Operation, maintenance

Owner service procedures

Technical data

Index



Overview

Controls

Maintenance

Repairs

Data

Index

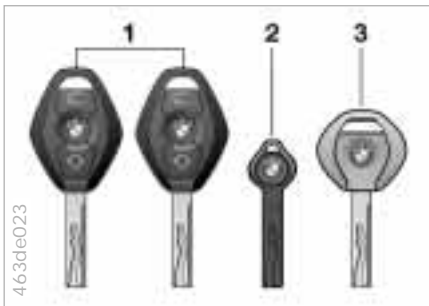

- 1 The master keys with remote control determine the functions of the Key Memory. Refer to page [55](#).
You can mark individual keys for subsequent identification by applying the colored decals that you received when accepting delivery of your vehicle

 There is an extended-life battery in every master key that is charged automatically in the ignition lock as you drive.

For this reason, if you have a master key that is not in regular use, you should use that key approx. once every year while driving for an extended period to charge the battery. For additional information refer to page [28](#). ◀

- 2 Spare key for storage in a safe place such as in your wallet. This key is not intended for continuous use

- 3 Door and ignition key
The lock for the glove compartment cannot be operated with this key. This is recommended for valet parking, for instance

Central locking system

The concept

The central locking system is ready for operation when both front doors are closed. The system engages and releases the locks on the

- ▷ doors
- ▷ luggage compartment lid
- ▷ fuel filler door.

The central locking system can be operated

- ▷ from outside via the driver's door lock as well as via the remote control
- ▷ from inside via the central locking system button.

The fuel filler door is not locked when you open the vehicle from the inside (refer to page [31](#)). The anti-theft system is automatically armed whenever you activate the central locking system from outside of the vehicle. Both the door locks and release handles remain locked. The alarm system is also activated or deactivated.

When you use the central locking system to lock the doors from inside the vehicle, it will automatically disengage the locks if an accident occurs, except on doors that have been locked individually using the lock buttons, refer to page 31. The accident response routine also includes automatic activation of the hazard warning flashers and the interior lamps.

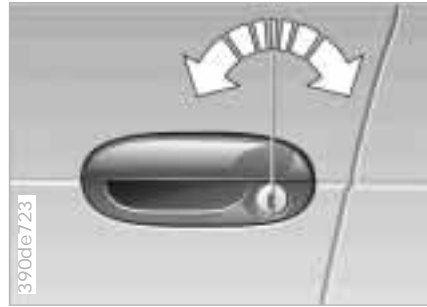

Using the key

One turn of the key in the driver's door lock unlocks the driver's door only. Turning the key a second time unlocks all of the remaining doors, the luggage compartment lid and the fuel filler door.

 Vehicles without armored glass: do not lock the vehicle if anyone will be remaining inside, as it would then be impossible for the occupant(s) to disengage the locks from the inside. ◀

 You can have a signal set as an acknowledgment message that the vehicle is locked correctly. ◀

Convenience operation

You can also operate the electric power windows and the sliding/tilt sunroof via the door lock.

- ▷ To open: with the door closed, turn the key to the "Unlock" position and hold it
- ▷ To close: with the door closed, turn the key to the "Lock" position and hold it.

 Watch the closing process carefully and be sure that no one is trapped by the closing motion. Releasing the key stops the operation. ◀

Manual operation

(in the event of an electrical malfunction)

Turn the key all the way to the extreme left or right to unlock/lock the driver's door.

28 Opening and closing – via the remote control

The concept

The remote control gives you an exceptionally convenient method for unlocking and locking your vehicle. Furthermore, it provides two additional functions that can only be executed by means of the remote control:

▷ To switch on interior lamps, refer to page 29

With this function, you can also "search for" your vehicle – when parked in an underground garage, for instance

▷ To open the luggage compartment lid, refer to page 29

The luggage compartment lid will open slightly, regardless of whether it was previously locked or unlocked

▷ Panic mode, refer to page 29

In case of danger, you can trigger an alarm.

When you unlock (lock) your vehicle the system automatically deactivates (activates) the anti-theft system and disarms (arms) the alarm system while also switching on (off) the interior lamps.



You can have a signal set as an acknowledgment message that the vehicle is locked correctly. ◀



- 1 Unlock, convenience opening and alarm system
- 2 Lock and secure, interior lamp activation, disarming tilt alarm sensor and interior motion sensor
- 3 Open the luggage compartment lid, panic mode

Master keys with remote control



Since passengers or animals remaining in the vehicle might be able to lock the doors from the inside, take the vehicle's keys with you so that the vehicle can be opened again from the outside at any time. ◀



Master keys that are used repeatedly are always ready for operation, since the battery in the key is charged automatically in the ignition lock as you drive.

If it is no longer possible to unlock the vehicle via the remote control, the battery is discharged. Use this key while driving for an extended period in order to recharge the battery. For more information refer to page 26.

Prevent unauthorized use of the remote control by surrendering e.g. only the door and ignition key 3 or the spare key 2 (refer to page 26) when leaving the vehicle for valet parking.

In the event of a system malfunction, please contact your BMW center, which is also your source for replacement keys. ◀

Opening and closing – via the remote control

To unlock



Press button.

Press the button once to unlock the driver's door and the fuel filler door only; press a second time to unlock all remaining doors as well as the luggage compartment lid.

Convenience opening mode



Press and hold button to open the electric power windows and sliding/tilt sunroof.

To lock and secure



Press button.

 Vehicles without armored glass: Do not lock the vehicle if anyone will be remaining inside, as it would then be impossible for the occupant(s) to disengage the locks from the inside. ◀

To deactivate the tilt alarm sensor and the interior motion sensor



Press button a second time immediately after locking.
For additional information: refer to page [36](#).

To switch on the interior lamps



With the vehicle locked, press button.

To open the luggage compartment lid



Press button.

The luggage compartment lid will open slightly, regardless of whether the lid was previously locked or unlocked.

 Before and after a trip, be sure that the luggage compartment lid has not been opened unintentionally. ◀

Panic mode



Provided that the alarm system is armed, you can respond to imminent danger by holding down the button for between two and five seconds.

To cancel alarm



Press button.

30 Opening and closing – via the remote control

External systems

External systems or devices may cause local interference in the functions of the remote control.

If this should occur, you can unlock and lock the vehicle via the door lock with a master key.

For US owners only

The transmitter and receiver units comply with part 15 of the FCC (Federal Communications Commission) regulations. Operation is governed by the following:

FCC ID: LX8EWS
 LX8FZVS
 LX8FZVE

Compliance statement:

This device complies with part 15 of the FCC Rules. Operation is subject to the following two conditions:

- ▷ This device may not cause harmful interference, and
- ▷ this device must accept any interference received, including interference that may cause undesired operation.



Any unauthorized modifications to these devices could void the user's authority to operate the equipment. ◀

Opening and closing – from the inside



Use this button to operate the central locking system when the front doors are closed. The doors and luggage compartment lid are unlocked or locked only. The anti-theft alarm system is not activated. Also, the fuel filler door remains unlocked to allow refueling.



The central locking system can be locked automatically as soon as you begin to drive, if you desire. You may also have this function programmed into individual keys. ◀



- If only the driver's door was unlocked from the outside and you press the button
- ▷ all other doors, the luggage compartment lid and the fuel filler door will be unlocked if the driver's door is open
 - ▷ the driver's door will be locked again when it is closed. ◀

To unlock and open the doors

- ▷ Either unlock the doors together with the button for the central locking system and then pull each of the release handles above the armrests or
- ▷ pull the release handle for each door twice: the first pull unlocks the door, and the second one opens it.

To engage the locks

- ▷ Use the central locking button to lock all of the doors simultaneously, or
- ▷ press the individual safety lock buttons down. As an added design feature to prevent the driver from being inadvertently locked out of the vehicle, the driver's door safety lock button will not engage as long as the door is open.



Never use the lock buttons while the vehicle is underway, as the doors would then fail to open automatically in the event of an accident. Since passengers or animals remaining in the vehicle might be able to lock the doors from the inside, take the vehicle's keys with you so that the vehicle can be opened again from the outside at any time. ◀

32 Luggage compartment lid

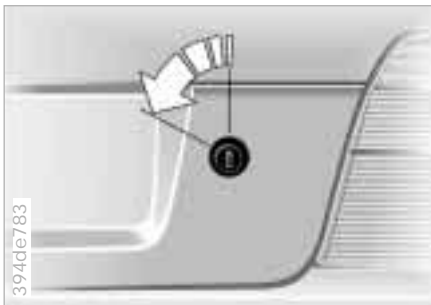

The lock

Only the master key (refer to page 26) fits in the lock for the luggage compartment lid.

To open separately

Turn the master key to the left in the luggage compartment lock, continuing until it stops – the luggage compartment lid will open slightly.

The luggage compartment is locked again as soon as you close the lid.

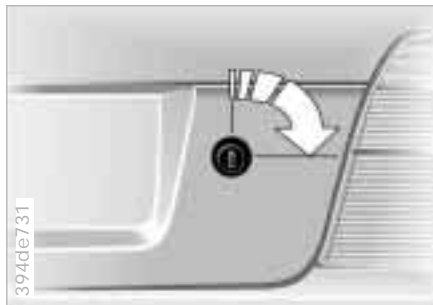

To secure separately

Turn the master key to the right past the pressure point and then pull it out in the horizontal position.

This locks the luggage compartment and disconnects it from the central locking system. This feature can be used to prevent unauthorized access to the luggage compartment when you hand over the door and ignition key 3 (refer to page 26) for valet parking, etc.

Manual operation

(in the event of an electrical malfunction)

Turn the master key to the left in the luggage compartment lock all the way to the stop – the luggage compartment lid will open slightly.

The luggage compartment is locked again as soon as you close the lid.

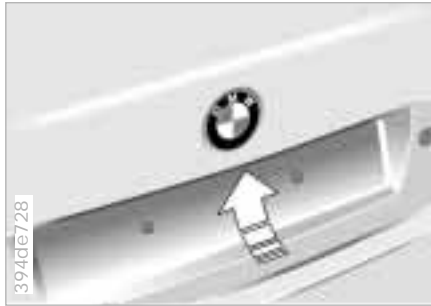

To open from the outside

Press the button (arrow): the luggage compartment lid opens slightly.

The luggage compartment is illuminated when the luggage compartment lid is opened.



To open from the inside

Provided the luggage compartment has not been locked separately, you can use this button to open it when the vehicle is stationary.



To close

The handle recess (arrow) next to the lock mechanism is designed to assist you in closing the luggage compartment lid.

 Operate the vehicle only when the luggage compartment lid is completely closed. An open lid would allow exhaust fumes to penetrate into the interior of the vehicle. Should it be absolutely necessary to operate the vehicle with the luggage compartment lid open:

- ▷ Close all windows. Shut the sliding/tilt sunroof
- ▷ Set the automatic climate control for maximum airflow, refer to page 89. ◀

34 Luggage compartment lid Luggage compartment



Emergency release

This lever releases the luggage compartment lid from the luggage compartment's interior.

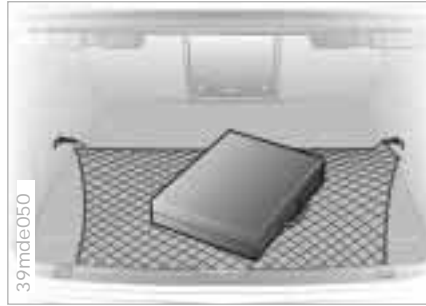

Luggage net

Use the luggage net to secure smaller items of luggage.

If you place objects on the luggage net, this helps to prevent them from moving.

Lashing eyes for attaching flexible straps* to secure your luggage are located in the corners of the luggage compartment.

Refer also to "Cargo loading" on page [102](#).



Hanger*

On the left-hand side of the luggage compartment is a hanger for fastening shopping bags, packages and similar items.

Alarm system

The concept

The vehicle alarm system responds:

- ▷ When a door, the hood or the luggage compartment lid are opened
- ▷ To movement inside the vehicle (interior motion sensor)
- ▷ Variations in the vehicle's tilt angle of the kind that occur during attempts to steal the wheels or tow the vehicle
- ▷ To interruption of battery voltage.

The system responds to unauthorized vehicle entry and attempted theft by simultaneously activating the following:

- ▷ Sounding an acoustical alarm for 30 seconds
- ▷ The hazard warning flashers are activated for approx. five minutes
- ▷ The high beams flash on and off in the same rhythm as the hazard warning flashers.

To arm and disarm the alarm system

When the vehicle is locked or unlocked with the key or the remote control, the alarm system is also simultaneously armed or disarmed.



You can have different acknowledgment messages set to confirm arming and disarming. ◀



You can also open the luggage compartment lid when the system is armed by pressing the button on the remote control (refer to page 29). When you close the luggage compartment lid, the luggage compartment is secured again.

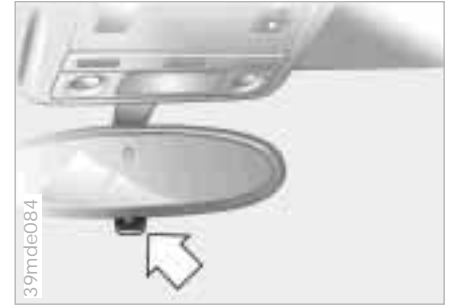

Indicator lamp displays

- ▷ The indicator lamp below the interior rearview mirror flashes continuously: the system is armed
- ▷ The indicator lamp flashes during arming: a door (or doors), the hood, luggage compartment lid or rear window are not completely closed. Even if you do not respond by securing the indicated area, the system will start monitoring all other areas, and the indicator lamp flashes continuously after 10 seconds. However, the interior motion sensor is not activated
- ▷ If the indicator lamp goes out when the system is disarmed: no manipulation or attempted intrusions have been detected in the period since the system was armed

36 Alarm system

- ▷ If the indicator lamp flashes for 10 seconds when the system is disarmed: an attempted entry has been detected in the period since the system was armed.

Following triggering of an alarm, the indicator lamp will flash continuously.

Avoiding unintentional alarms

The tilt alarm sensor and interior motion sensor may be switched off at the same time. You can do this to prevent an unintentional alarm from being triggered (in garages with elevator ramps, for instance), or when the vehicle is transported by trailer or train:

Actuate the lock (= arm the system) twice; in other words, press button 2 of the remote control twice in succession (refer to page 29). You may also actuate the locks twice with the key (refer to page 27).

The indicator lamp lights up briefly and then flashes continuously. The tilt alarm sensor and the interior motion sensor are deactivated as long as the system is armed.

Interior motion sensor

In order for the interior motion sensor to function properly, the windows and sliding/tilt sunroof must be completely closed.

Nevertheless, you should deactivate the interior motion sensor (refer to "Avoiding unintentional alarms") if

- ▷ children or animals are left in the vehicle
- ▷ the windows or the sliding/tilt sunroof are being left open.

Electric power windows



To open and close windows

In ignition key position 1 and 2:

- ▷ Depress the rocker switch until you feel resistance:
The window continues moving for as long as you maintain pressure on the switch
- ▷ Press the rocker switch beyond the pressure point:
The window moves automatically. Press the switch a second time to stop the window.

Electric power windows

After the ignition has been switched off:

- ▷ You can still operate the power windows as long as neither of the front doors has been opened. To open a window, press the switch beyond the pressure point.

 When leaving the vehicle, always remove the ignition key from the lock and remember to close the doors to prevent children from operating the power windows and injuring themselves, etc. ◀

For convenience operation via the door lock or remote control, refer to page [27](#) or [29](#).

Safety feature

A contact strip is located on the inside upper frame of each of the windows. If pressure is exerted against this contact strip while a window is being raised, the system will respond by stopping the window and then retracting it slightly.

 Despite this safety feature, be extremely careful to ensure that the closing path of the window is not obstructed. Otherwise, an object might not touch the contact strip in some situations (very thin objects, for instance). You can disable this safety feature by pressing the switch beyond the pressure point and holding it. Because the power windows are sealed at high pressure to prevent wind noise when closed, a powerful motor is required for efficient closing. When closing the windows, always be sure that they are not obstructed in any way. Unsupervised use of these systems can result in serious personal injury. Remove the ignition key to deactivate the electric power windows whenever you leave the vehicle. Never leave the keys in the vehicle with unsupervised children. Never place anything that could obstruct the driver's vision on or next to the windows. ◀



Safety switch

With the safety switch you can prevent the rear windows from being opened or closed via the switch in the rear passenger area (by children, for example).

 Press the safety switch whenever children are riding in the rear of the vehicle. Careless use of the power windows can lead to injury. ◀

 To prevent injuries, exercise care when closing the sliding/tilt sunroof and keep it in your field of vision until it is shut.

Before leaving the vehicle, switch off the electric sunroof mechanism by removing the ignition key. Do not leave children unattended in the vehicle with access to vehicle keys. The key can be used to start the engine and to operate vehicle systems such as the power sunroof, etc. Unsupervised use of these systems can result in serious personal injury. ◀

For convenience operation via the door lock or remote control, refer to page 27 or 29.



Raising - opening - closing

With the ignition key in position 1 or higher, press the switch or slide it in the desired direction until you feel resistance.

When lifting, the headliner retracts several inches.

 The headliner insert can not be closed with the sunroof in its raised position. ◀

After the ignition has been switched off, you can still operate the sliding/tilt sunroof as long as no front door has been opened.

Automatic opening and closing

Press the switch past the pressure point briefly: the sunroof travels to either the fully-closed or fully-open position.

Other automatic operations are:

- ▷ With the sunroof open, press the switch briefly toward "Lift": the sunroof automatically extends to its fully-raised position
- ▷ With the sunroof lifted, press the switch briefly toward "Open": the sunroof automatically opens all the way.

Pressing the switch again stops the motion immediately.

Safety feature

If the sliding/tilt sunroof encounters resistance at a point roughly past the middle of its travel when it is closing, the closing cycle is interrupted and the sunroof will open again slightly.

Sliding/tilt sunroof*

 Despite this safety feature, be extremely careful to ensure that the closing path of the roof is not obstructed. Remember that the safety mechanism may not be able to detect every kind of potential obstruction (very thin objects, for instance). You can disable this safety feature by pressing the switch beyond the pressure point and holding it. ◀

Sliding/tilt sunroof with glass moonroof insert*

The options and control procedures are essentially the same as those previously described for the sliding/tilt sunroof. In order to open the raised roof, press the control switch towards "Open" and maintain pressure until the roof has reached the desired position. The headliner insert slides back somewhat when you raise the sunroof, and retracts along with the sunroof panel when you slide it back. The insert then remains open, and you can slide it back and forth to adjust it whenever the sunroof is not fully retracted.



Interruption in the electrical supply

After interruptions in the electrical supply (when the battery is disconnected, for instance), the sunroof may only lift. To reinitialize the mechanism:

1. Raise the sliding/tilt sunroof fully
2. Press and hold the switch for approx. 20 seconds.



Manual operation

In the event of an electrical malfunction, you can also operate the sliding/tilt sunroof manually.

1. Remove the interior lamp, then reach into the exposed opening and press out the cover
2. Use the Allen key from the onboard tool kit (refer to page 124) to turn the sliding/tilt sunroof in the desired direction.

For relaxed and fatigue-free driving you should select a seating position that reflects your personal requirements.

Correct seating position combines with safety belts and airbags to enhance occupant safety in the event of an accident. To ensure that the vehicle's safety systems provide you with optimal protection, we request that you direct your careful attention to the following section.

For additional information on transporting children, refer to page 51.

Sitting safely with airbags

 Always maintain an adequate distance between yourself and the airbags. Always hold the steering wheel by the rim with the hands at the 9 and 3-o'clock positions to keep any chance of injury to hands or arms to an absolute minimum should the airbag be deployed. Never allow any objects, individuals or animals to obstruct the areas between passengers and airbags. Never use the front airbag's cover as a storage tray or support for objects of any kind. Never allow front passengers to rest their feet or legs on the airbag cover. ◀

For airbag locations and additional information on airbags refer to page 49.

Sitting safely with safety belt

 Never allow more than one person to wear a single safety belt. Never allow infants or small children to ride in a passenger's lap. Avoid twisting the belt while routing it firmly across the pelvis and shoulder, wear it as snugly against your body as possible. Do not allow the belt to rest against hard or fragile objects in your pockets. Do not route the belt across your neck, or run it across sharp edges. Avoid wearing bulky clothing and pull on the lap belt periodically to retension it over your shoulders. In the event of a frontal impact, a loose lap belt could slide over the hips, leading to abdominal injury. In addition, the safety belt's restraint effectiveness is reduced if it is worn loosely. Expectant mothers should always wear their safety belts, taking care to position the lap belt against the lower hips, where it will not exert pressure against the abdominal area. ◀

For information on using the safety belts refer to page 44.

Seats

When adjusting your seat, always observe the following precautions

 Never try to adjust your seat while operating the vehicle. The seat could respond with an unexpected movement, and the ensuing loss of vehicle control could lead to an accident. Never ride with the backrest reclined to an extreme horizontal angle (important for front passengers to remember), otherwise, there is a risk that you will slide under the safety belt in an accident, thus negating the protection the safety belt provides. Do not move the seats to the rear when the vehicle is at an extreme angle (on garage ramps or steep slopes, for example). If you do so, the automatic safety belt height adjustment can be disengaged. ◀

Seat adjustment

- ▷ BMW M sport seat, refer to page 41
- ▷ BMW comfort seat, refer to page 42
- ▷ Head restraints, refer to page 43
- ▷ BMW active seat, refer to page 43



- 1 Tilt (driver's seat only)
- 2 Backward/forward adjustment
- 3 Cushion height
- 4 Backrest angle
- 5 Head restraint height

To adjust the angle of the head restraint manually, tilt to the desired angle.

 Please refer to the adjustment instructions on page 40 to reduce the risk of personal injury. ◀



Lumbar support

You can adjust the backrest's contour for additional support in the curvature of your spine's lumbar region.

The upper hips and spinal column receive supplementary support to help you maintain a relaxed, upright seating position.

- ▷ Press front/rear of switch: increase/decrease curvature
- ▷ Press the upper/lower end of the switch: increase the upper/lower curvature.



Thigh support

Press switch: you can adjust the thigh support for maximum personal comfort.



This seat also allows you to make additional adjustments using the power seat system (refer to BMW M sport seat, page 41) for

- 1 Lumbar support
- 2 Shoulder support

 Please refer to the adjustment instructions on page 40 to reduce the risk of personal injury. ◀

Lumbar support

Refer to BMW M sport seat on page 41.



Shoulder support

Press the switch: the support angle of the upper backrest section is adjusted. You can use the adjustable upper backrest for supplementary support in the shoulder region. This provides a relaxed seating position and helps relieve stress on the shoulder muscles.

To obtain the optimal shoulder support position, we recommend:

Driver and front passenger:

1. Adjust the upper backrest section to its extreme rear position
2. Adjust for the optimal seating position as described on page 40
3. Bring the upper backrest section forward until your shoulders enjoy firm support.

Front passenger's seat adjusted for relaxed traveling:

1. Adjust the upper backrest section to its extreme rear position
2. Lower the backrest slightly to increase the tilt angle
3. Bring the upper backrest section forward until your shoulders enjoy firm support.



Make corrections in the forward/backward adjustment of the seat to ensure that the safety belt still fits firmly against your body. Failure to observe this precaution can reduce the amount of protection provided by your safety belt. ◀

Head restraints



Head restraints

To adjust the angle of the front head restraints: tilt the head restraint.

To adjust the height of the rear head restraints: pull up or push down.



Head restraints reduce the risk of spinal injury in the event of an accident.

Adjust the head restraint so that its center is approximately level with your ears.

Leave the center-rear head restraint in the fully-lowered position at all times. Extending it limits its function. ◀

BMW active seat*



Active changes in the seat's cushion helps to avoid muscle cramps, pain in the spine's lumbar region and fatigue.

To activate, press the button.

44 Safety belts



The shoulder belt anchor automatically adjusts to continue providing an optimum fit when you move the seat forward or back.

 The rear belt buckle with the word "CENTER" is intended exclusively for the passenger sitting in the middle. Vehicles with through-loading system*: please refer to the instructions for using the rear center belt found on page 99. ◀

Drive with your safety belt on

Always fasten your safety belt before starting off. As supplemental restraint devices, the airbags are designed to enhance the effectiveness of the safety belts, and not to replace them.

To close

Make sure you hear the catch engage in the belt buckle.

To open

1. Press the red button in the belt buckle
2. Hold the end of the belt
3. Guide the belt back into the inertia reel.

 If the safety belt system has been subjected to the stresses involved in an accident or otherwise damaged: to ensure that the safety belts continue to provide effective protection, always have the entire safety belt mechanism replaced and the belt anchorages inspected at your BMW center. If a child-restraint system was in the vehicle during an accident, consult the manufacturer's instructions regarding replacement. ◀



You can store and call up three different seat, exterior mirror and steering wheel positions. The illustration shows the buttons on the driver's door for making these position adjustments.

The setting for the lumbar support is not stored in memory.

To store

1. Turn the key to ignition key position 1 or 2
2. Adjust to the desired positions for the seat, exterior mirror and steering wheel
3. Press the MEMORY button: the indicator lamp in the button lights up
4. Press memory button 1, 2 or 3, as desired. The indicator lamp goes out.

To select a stored setting

Convenience function:

1. The driver's door remains open after unlocking or the ignition key is in position 1
2. Briefly press memory button 1, 2 or 3, as desired.
Movement stops immediately when one of the seat adjustment or memory buttons is activated during the adjustment process.

Safety function:

1. With the driver's door closed and the ignition key either removed or in position 0 or 2
2. Maintain pressure on the desired memory button (1, 2 or 3) until the adjustment process is completed.

If you should happen to press the MEMORY button by mistake: press the button a second time; the indicator lamp goes out.

 Do not call up a position from the memory while the vehicle is moving. There is a risk of accident from unexpected movement of the seat or steering wheel. ◀

46 Seat, mirror and steering wheel memory

 Your BMW center can adjust your vehicle's systems in such a manner that your personalized settings are automatically called up for the seat, mirror and steering wheel positions when you unlock the vehicle with your personal remote control key. ◀

 Before using the key memory feature to unlock the vehicle always ensure that no objects are stored in the footwell behind the driver's seat. If you fail to do so, persons or objects could be injured or damaged if the seat should move backward. ◀



Passenger-side exterior mirror tilt function

(automatic curb monitor)

- 1 Move the mirror selector switch (arrow) to the "driver's mirror" position
- 2 When the gearshift lever or the selector lever is placed in "Reverse," the passenger-side mirror tilts downward to help the driver monitor the area directly adjacent to the vehicle during parking (curbs, etc.).

You can deactivate this automatic feature by setting the mirror selector switch to the "passenger-side" position.

Seat heating



The seat cushion and backrest can be heated with the ignition key in position 2. You can select different heating modes by repeatedly pressing the buttons.

You can also switch the higher heating modes off directly: Press the button and hold it slightly longer.

Steering wheel

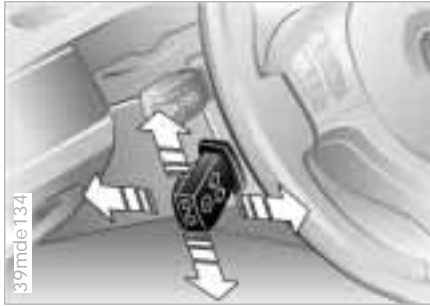

Adjustments

The steering wheel can be moved in any of four directions. Adjust by moving the control lever in the desired direction.



Do not adjust the steering wheel while the vehicle is moving. There is a risk of accident from unexpected movement. ◀

To store the steering wheel setting, refer to "Seat, mirror and steering wheel memory" on page [45](#).

Automatic steering wheel adjustment

In order to make it easier to get into and out of the vehicle, the steering wheel automatically moves into the top position and returns to the driving (memory) position.

This automatic feature is controlled by the position of the ignition key and by the driver's door.



Your BMW center can adjust your vehicle's systems in such a manner that your personalized setting is automatically called up for the steering wheel position when you unlock the vehicle with your personal key. ◀



Exterior mirrors

- 1 Switch for 4-way adjustment
- 2 Selector switch for changing between mirrors

To adjust manually

The mirrors can also be adjusted by hand:

Press the edge of the lens.

To store mirror settings, refer to "Seat, mirror and steering wheel memory" on page 45.

Convex mirror

 The passenger-side mirror features a convex lens. When estimating the distance between yourself and other traffic, bear in mind that the objects reflected in the mirror are closer than they appear. ◀

 Your BMW center can adjust your vehicle's systems in such a manner that your personalized setting is automatically called up for the mirror position when you unlock the vehicle with your personal remote control. ◀

Self-defrosting mirrors

Both mirrors are automatically defrosted with the ignition key in position 2.



Interior and exterior mirrors, automatic dimming feature

These mirrors automatically respond to glare from following vehicles by dimming through an infinitely variable range. The mirrors automatically revert to their clear, undimmed setting whenever you select reverse.

The interior rearview mirror's dimming function is regulated by two photocells; one is integrated in the mirror's lens (arrow), while the other is located at an offset position on the rear of the mirror.

To ensure that the mirror continues to operate efficiently, ensure that the area adjacent to the photocells remains clear and unobstructed. Refrain from attaching stickers or other objects to windshield immediately behind the rearview mirror.

Airbags

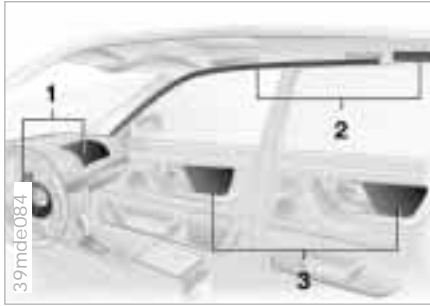

- 1 Front airbags on the driver and passenger sides
- 2 Head protection airbags on driver and passenger side (front and rear*)
- 3 Side airbags on driver and passenger side (front and rear*)

Protective effect

The front airbags help to protect the driver and passenger in the event of a head-on collision where the protection provided by the safety belt alone would not be adequate. The head protection airbags and side airbags help provide protection in the event of a collision from the side. Each of the side airbags is designed to help support the occupant's upper body.

 The side airbags in the rear passenger area* of your vehicle may already have been deactivated, either at the time of manufacture or by a BMW center. You may have them activated if you desire to do so. Please contact your BMW center for additional information. ◀

For information on the correct seating position, refer to page 40.

 The airbags will not be triggered in the event of a minor accident, a vehicle rollover or a collision from the rear. ◀

 Never apply stickers or adhesive-backed objects of any kind to the airbag covers. Never attempt to reupholster the covers or modify them in any way. If the airbags deploy in response to an accident, if you note any signs of system malfunction, or if you wish to have any parts of the airbag passenger-restraint system deactivated, always contact your BMW center, to whom we strongly urge you to entrust all testing, repair and dismantling operations. Never attempt to modify or tamper with either the system's electrical wiring or any of its individual components.

System components include the upholstered surfaces on the steering wheel, instrument panel, the trim panels on the front and rear doors and the roof braces as well as the sides of the headliner above the doors.

Never attempt to remove or dismantle the steering wheel.

To ensure compliance with official safety regulations, always entrust disposal of airbag generators to your BMW center. Attempts to carry out service procedures undertaken by anyone other than specially-trained professionals can result in system failure or undesired airbag deployment, both of which can lead to personal injury. If the airbags deploy in response to an accident, always remember to avoid all contact with system components, as they are hot and can cause burns in the period immediately following deployment. ◀

 All vehicle occupants should always sit upright and be properly restrained (infants and small children in appropriate child-restraint systems; larger children and adults using the safety belts). Never let an occupant's head rest near or on a side airbag: the inflating airbag could cause a serious or

50 Airbags

fatal injury. Please note that the word "Airbag" imprinted on the door trim panel indicates the airbag's location. Accident research shows that the safest place for children in an automobile is in the rear seat. However, a child sitting in the rear seat and not properly restrained may place his or her head on or near the side airbag, if installed. For example, a child – even though belted – may fall asleep with his or her head against the side airbag. It may be difficult for a driver to ensure that children in the rear seat will remain properly positioned at all times and do not place their heads on or near the side airbag. Therefore, we recommend that the rear-seat side airbags, if provided, be deactivated if you plan to transport children in the rear seat. The rear-seat side airbags may already have been deactivated, either at the time of manufacture or by a BMW center. Labels in the rear door opening should indicate the status of your rear-seat side airbags. If you are uncertain of their status, or wish to have the airbags activated or deactivated, please contact your BMW center. ◀

Even when all these guidelines are followed, there is still a small residual risk of injuries to the face, hands and arms occurring in isolated instances. The ignition and inflation noise may provoke a mild temporary hearing loss in extremely sensitive individuals. Airbag warning information is also provided on the sun visors.



This is the right way a child should sit in a child restraint when rear side airbags (arrow) are provided.



This is the right way a larger child should sit wearing the safety belt when rear side airbags (arrow) are provided.

Indicator lamp



The indicator lamp indicates the operational status of the airbag system from ignition key position 1.

System operational:

- ▷ The indicator lamp comes on briefly then goes out.

System malfunction:

- ▷ The indicator lamp fails to come on
- ▷ The indicator lamp comes on briefly before going out and then lighting up again.

Please respond to any malfunctions in the system by immediately having it inspected at your BMW center; otherwise the airbag could fail to respond to an accident in which both the angle and the severity of the impact would normally trigger airbag deployment.

Commercially-available child-restraint systems are designed to be secured with a lap belt or with the lap belt portion of a combination lap/shoulder belt. Improperly or inadequately installed restraint systems can increase the risk of injury to children. Always read and follow the instructions that come with the system.

52 Transporting children safely

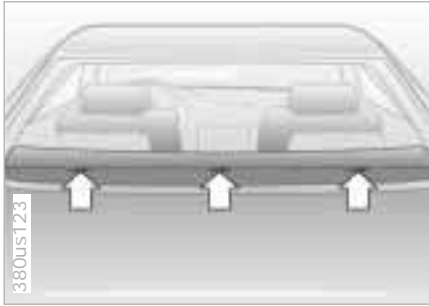

Child-restraint system with tether strap

If you use a child-restraint system with a tether strap, three additional tether anchorage points have been provided – refer to the arrows in the illustration. Depending on the location selected for seating in the rear passenger area, attach the tether strap to the corresponding anchorage point to secure the child-restraint system, as shown in the following illustration.

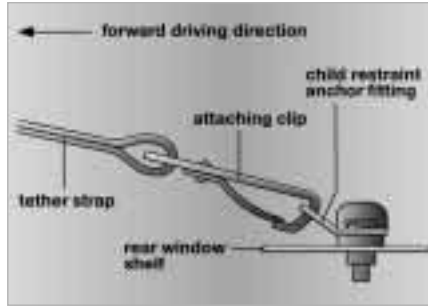

Each seating position is fitted with a head restraint. Lift the head restraint and pass the tether strap between the head restraint and the seat back. It is recommended to readjust the head restraint into the lowest possible position.

Adjust the tether strap according to the child restraint manufacturer's instructions.



Before installing any child-restraint device or child seat, please read the following: Never install a rearward-facing child-restraint system in the front passenger seat of this vehicle.

Your vehicle is equipped with an airbag supplemental restraint system for the front passenger. Because the backrest on any rearward-facing child-restraint system (of the kind designed for infants under 1 year and 20 lbs./9 kg) would be within the airbag's deployment range, you should never mount such a device in the front passenger seat, since the impact of the airbag against the child restraint's backrest could lead to serious or fatal injuries.

If it is necessary for a child (not an infant) to ride in the front seat, certain precautions should be taken. First, move the passenger seat as far away from the instrument panel as possible.

Transporting children safely

This important precaution is intended to maximize the distance between the airbag and the child. Older children should be tightly secured with a safety belt, after they have outgrown a booster seat that is appropriate for their age, height and weight.

Younger children should be secured in an appropriate forward-facing child-restraint system that has first been properly secured with a safety belt. Never install a rearward-facing child-restraint system in the front passenger seat. We strongly urge you to carefully read and comply with the instructions for installation and use provided by the child restraint's manufacturer whenever you use such a device.

Be sure that all occupants (of all ages) remain properly and securely restrained at all times. ◀

All rear seating positions in your vehicle meet the recommendations of SAE J1819, an industry-recommended practice for securing child-restraint systems in motor vehicles.



Child-restraint installation

All of the rear belt retractors and the front passenger's safety belt can be locked for mounting and securing child-restraint systems. A label with the appropriate instructions is located in the immediate vicinity of the buckle latch of each safety belt.

Lock the safety belt

Extract the entire length of the belt from the belt retractor. Allow the reel to retract the belt somewhat and engage the buckle, then tighten the belt against the child-restraint system. The retraction mechanism is now locked.

Unlock the safety belt

Release the buckle, remove the child-restraint device and allow the belt retractor to reel the belt completely in.



LATCH child-restraint anchorage points*

LATCH: Lower Anchor and Tethers for Children.

Snap the rear center lap belt into the buckle with the word CENTER and then pull the belt away from the area where the child restraint will be mounted.

 Vehicles with through-loading system*: use the small lock mechanism to connect the two sections of the center belt, refer to page 99. ◀



The rear outer seating positions are provided with anchors for a LATCH child-restraint system. The illustrations show the right rear seat as an example.

The outer anchorage points for the LATCH child-restraint system are marked with small flags.



Canadian models only:
The anchorage points for the LATCH child-restraint system are marked with buttons.

 To attach the LATCH child-restraint system, your BMW center will provide an installation guide. The guide, although not necessary for installation of a LATCH child-restraint system, will facilitate the installation and also help protect the vehicle's seating surfaces. Carefully read and comply with the safety precautions of the manufacturer. ◀

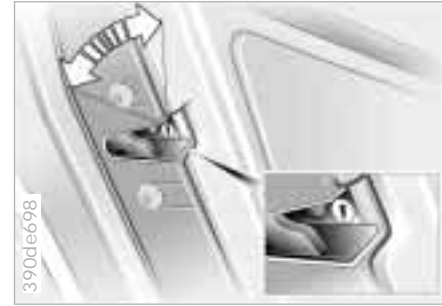

Child-safety locks

Insert the key in the slot of a rear door lock and turn it outward:

The door can now be opened from the outside only.

Vehicle Memory, Key Memory



How the system functions

No doubt you have reflected at one time or another on how great it would be if you could permanently configure your vehicle's various features and adjustments to mirror your own individual preferences. In engineering your vehicle, BMW has incorporated a number of options for personal adjustment that can be programmed into your vehicle at your BMW center.

The available configuration data fall into two categories, according to whether their primary orientation is the vehicle ("Vehicle Memory") or the individual ("Key Memory"). Provided that each person has a separate remote-control key, you can have your BMW center enter two personal adjustments for two different individuals into the system.

When your vehicle is unlocked with the remote control, the vehicle recognizes the individual user by means of a data exchange with the key, and makes adjustments accordingly.

In order for you to distinguish between different keys, colored decals are supplied together with the keys.

What the system can do

Your BMW center can provide you with details on the capabilities of the Vehicle Memory and Key Memory systems. A few examples follow below:

Examples for Vehicle Memory:

- ▷ Various signals as acknowledgment when locking or unlocking your vehicle
- ▷ Activates/deactivates the "Follow me home" function.

Examples for Key Memory:

- ▷ Locks the vehicle when you start off
- ▷ Automatically adjusts the driver's seat, the exterior mirrors and the steering wheel position to your personal programmed settings when you unlock the vehicle
- ▷ The automatic climate control assumes your preset comfort settings when you unlock the vehicle.



You will see this symbol throughout the Owner's Manual. It is to remind you at appropriate places of the settings that are available to you. ◀

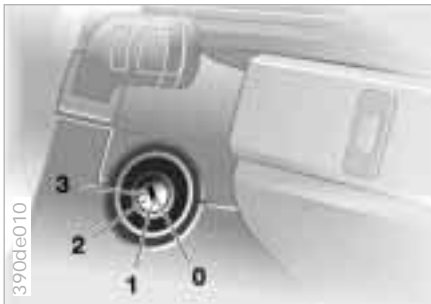

- 0 Steering locked
- 1 Steering unlocked
- 2 Ignition switched on
- 3 Starting engine

Steering locked

The key can be inserted or removed in this position only.

An acoustic warning is sounded when you fail to remove the ignition key after opening the driver's door.

After removing the key, turn the steering wheel slightly to the left or right until the lock engages.

Steering unlocked

Turning the steering wheel slightly to the right or left often makes it easier to turn the key from 0 to 1.

Individual electrical accessories are ready for operation.

Starting engine

Depress the clutch when starting the engine. A lockout prevents the engine from starting with the clutch engaged.

Starting the engine

Before starting

- ▷ Engage the parking brake
- ▷ Move the gearshift lever to the neutral position
- ▷ Depress the clutch pedal.



Do not allow the engine to run in enclosed spaces. The exhaust gases contain carbon monoxide, an odorless and colorless, but highly toxic gas. Breathing the exhaust gases poses an extreme health risk, and can lead to unconsciousness and death.

Do not leave the vehicle unattended with the engine running. An unattended vehicle with a running engine represents a potential safety hazard. ◀

Starting the engine

Starting engine

Do not press the accelerator pedal while starting the engine.

 While it is important not to release the key prematurely, you should also avoid allowing the starter to operate continuously for more than 20 seconds at a time. Release the ignition key immediately when the engine starts. ◀

Do not warm up the engine by allowing it to run with the vehicle parked. Instead, you should drive away immediately while taking care to avoid high engine speeds until the engine warms to its normal operating temperature. If the engine does not start on the first attempt (the engine is very hot or cold, for instance):

▷ Press the accelerator pedal halfway down while engaging the starter.

Cold starts at extremely low temperatures of roughly +5 °F (-15 °C) or below and at altitudes of over 3,300 ft (1,000 m):

▷ Allow the starter to turn somewhat longer (approx. 10 seconds) during your initial starting attempt.

The engine's idle speed is automatically regulated by the computerized engine-management system. A brief period at high idle is normal just after starting; the idle speed should gradually return to normal as the engine warms. Should the engine fail to revert to its normal idle speed after warming, a problem may exist: please refer the problem to your BMW center.

To prevent the battery from discharging, always switch off any electrical devices not in use, as well as the ignition when the vehicle is not being driven.

 Extended starting attempts, characterized by excessively frequent or long periods with the starter engaged, can lead to catalyst damage. ◀

 When driving, standing at idle, and parking the vehicle, take care to avoid contact between the exhaust system and flammable materials (grass, hay, leaves, etc.). Such contact could lead to a fire, resulting in serious personal injury and property damage. ◀

Switching off the engine 57

Turn the ignition key to position 1 or 0.

 Do not remove the ignition key while the vehicle is still moving. If you do so, the steering will lock, making it impossible to steer the vehicle. When you leave the vehicle, always remove the ignition key and engage the steering lock.

Always engage the parking brake when parking on hills and inclined surfaces, as even first gear or reverse may not provide adequate resistance to rolling. ◀



The parking brake is designed primarily to prevent the vehicle from rolling when it is parked. It operates on the rear wheels.

To engage

The lever engages automatically when it is pulled up, and the "PARK BRAKE" (in Canada "P") indicator lamp comes on in the instrument cluster in ignition key position 2. Refer to page 17.

To release

Pull up slightly on the lever, press the button and lower the lever.

⚠ If, in exceptional circumstances, it should be necessary to engage the parking brake while the vehicle is in motion, do not pull it with excessive pressure. Keep your thumb pressed against the release button while carefully pulling the lever up to apply moderate pressure.

Excessive pressure can lead to over-braking and loss of traction (fishtailing) at the rear axle.

The brake lamps do not come on when the parking brake is applied. Always engage the parking brake when parking on hills and inclined surfaces, as even first gear or reverse may not provide adequate resistance to rolling. ◀

You can help prevent corrosion and maintain balanced braking by periodically pulling up the parking brake lever gently while coasting to a stop at a traffic light. Always check traffic conditions first to avoid posing a hazard to yourself or other road users.



When shifting gears, always depress the clutch pedal all the way down, then move the gearshift lever until it engages securely in the desired gear.

You will also need to depress the clutch when starting the engine, as an automatic lockout prevents the starter from operating when the clutch is engaged.

When the vehicle lighting is switched on, the shift pattern is illuminated on the gearshift lever.

⚠ When shifting gears in the 5th/6th-gear plane, be sure to press the gearshift lever to the right in order to prevent inadvertent selection of a gear in the 3rd/4th-gear plane. ◀

Manual transmission

Reverse

Select only when the vehicle is completely stopped. Press the gearshift lever to the left to overcome the resistance.

As you do this, the backup lamps will turn on automatically when the ignition key is in position 2.



Do not hold the vehicle in place on slopes by slipping or "riding" the clutch. Use the parking brake instead. Riding the clutch causes the clutch assembly to wear out prematurely. ◀

Turn signal/Headlamp flasher

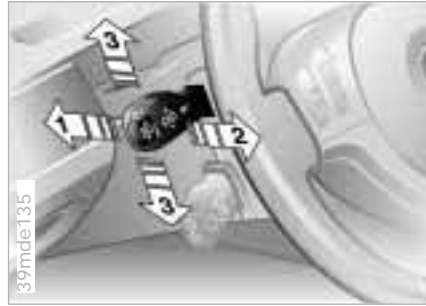

- 1 High beam (blue indicator lamp)
- 2 Headlamp flasher (blue indicator lamp)
- 3 Turn signal indicator (green indicator lamp accompanied by periodic clicking sound from the relay)

To signal briefly

Press the lever up to but not beyond the pressure point. It then returns to the center position when released.



If the indicator lamp and the clicking from the relay are both faster than normal, one of the turn signal indicators has failed. ◀

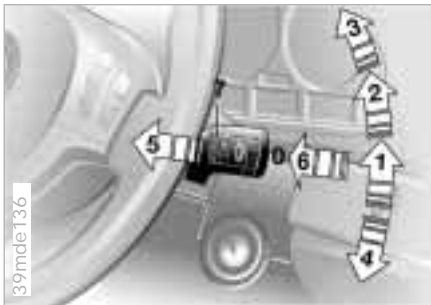

- 0 Wipers retracted
- 1 Intermittent mode or rain sensor*
- 2 Normal wipe
- 3 Fast wipe
- 4 Brief wipe
- 5 Cleaning windshield
- 6 Intensive cleaning
- 7 Rotary dial for control of the wipe interval in the intermittent mode or the sensitivity of the rain sensor

Intermittent mode or rain sensor*

Intermittent mode:

You can set the wipe interval to four stages with rotary dial 7. In addition, the wipe interval varies automatically depending on road speed.

Rain sensor:

The rain sensor is positioned on the windshield, directly ahead of the interior rearview mirror.

To activate the rain sensor:

Move the lever to position 1 with the ignition key in position 1 or higher. The wipers travel once across the windshield, regardless of the weather conditions.

You can leave the lever permanently in position 1. Whenever the ignition key is in position 1 or higher, all you then need to do to activate the rain sensor is briefly turn the rotary dial 7.

To adjust the sensitivity of the rain sensor:

Turn rotary dial 7.

To deactivate the rain sensor:

Put lever in position 0.



Turn the rain sensor off in automatic car washes. Failure to do so could result in damage caused by undesired wiper activation. ◀

Normal wipe

When the vehicle is stationary, the wipers automatically revert to intermittent wipe (not on vehicles with rain sensor).

Fast wipe

When the vehicle is stationary, the wipers operate at normal speed (not on vehicles with rain sensor).

Cleaning windshield

The system sprays washer fluid against the windshield and activates the wipers for a brief period.

Intensive cleaning

As in setting 5. In addition, an intensive-action washer fluid is first sprayed on the windshield.

Washer/Wiper system

Cleaning headlamps

When the headlamps are on, they are also cleaned automatically every fifth time you activate "Cleaning windshield" 5 or "Intensive cleaning" 6.



Do not use the washers if there is any danger that the fluid will freeze on the windshield, as your vision could be obscured. You can reduce this danger by adding a windshield washer antifreeze. Refer to page 115. Do not activate the washer if the reservoir is empty, as the washer pump could be damaged. ◀

Windshield washer jets

The windshield washer jets are warmed automatically when the ignition key is in position 2.

Cruise control

You can store and automatically maintain any desired vehicle speed above approx. 20 mph (30 km/h).

The cruise control is available whenever the engine is running and the system has been activated.

To activate the system



From ignition key position 2: Press the button and the indicator lamp on the instrument cluster (refer to page 18) will come on. You can now use the cruise control.



Do not use cruise control on twisting roads, when high traffic density prevents driving at a constant speed, or when the road surface is slick (snow, rain, ice) or loose (rocks or gravel, sand). ◀

To deactivate the system



Press button as often as needed until the indicator lamp in the instrument cluster goes out.

Cruise control is also deactivated when the ignition key is in position 0.

The speed stored in memory is deleted.

To maintain and store speed or to accelerate

Press button (+) briefly:

The system maintains and stores the current vehicle speed. Every time you tap the button, the speed increases by approx. 0.6 mph (1 km/h).

Press and hold button (+):

The vehicle accelerates without pressure on the accelerator pedal. When you release the button, the system stores and maintains the current speed.



If, on a downhill gradient, the engine braking effect is not sufficient, the controlled speed can be exceeded. Speed can drop on uphill grades if the engine output is insufficient. ◀

To decelerate

Press button (-) briefly:

If you are already driving with active cruise control, the speed is decreased by approx. 0.6 mph (1 km/h) every time you tap the button.

Press and hold button (-):

With the cruise control active, the system automatically reduces the throttle opening to slow the vehicle. When you release the button, the system maintains and stores the current speed.

To interrupt the cruise control

When the system is activated, press the button. The indicator lamp stays on.

You can use the cruise control again whenever you want by calling up the speed that was stored last.

In addition, cruise control is interrupted automatically:

- ▷ When the brakes are applied
- ▷ When you depress the clutch pedal
- ▷ If you exceed or fall below the programmed speed for an extended period (by depressing the accelerator, for example).

To recall the stored setting

Press button:

The vehicle accelerates to and maintains the last speed stored.

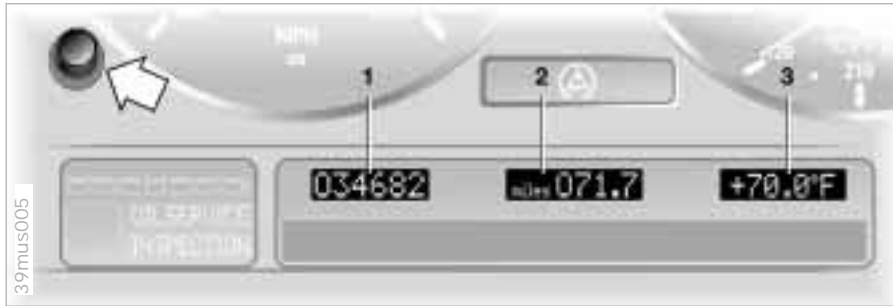

- 1 Odometer
- 2 Trip odometer
- 3 Outside temperature display

Odometer

You can activate the displays shown in the illustration with the ignition key in position 0 by pressing the button in the instrument cluster (arrow).

The range of available displays varies according to your individual vehicle's equipment.

Trip odometer

To reset the trip odometer to zero, press the button (arrow) with the ignition key in position 1 or higher.

Outside temperature display

The outside temperature appears in the display in ignition key position 1 and higher.

You can change the units of measurement (°F/°C) by

1. pressing and holding the button (arrow) with the ignition key in position 1
2. turning the ignition key to 0.

Ice warning

If the outside temperature drops to approx. +37.5 °F (+3 °C), a signal is sounded as a warning and the display flashes for a brief period.

 The ice warning does not alter the fact that surface ice can form at temperatures above +37.5 °F (+3 °C), on bridges or shaded road surfaces, for instance. ◀

64 Tachometer



The orange pre-warning zone appears depending on the engine temperature. As the engine temperature increases, more and more of the sectors of this pre-warning zone disappear.

Avoid engine speeds in the pre-warning zone if possible.

Do not operate the engine with the needle in the red overspeed zone of the gauge.

To protect the engine, the engine-management system interrupts the fuel supply when you approach this sector.

Engine oil temperature



The normal operating temperature range is between +176 °F (+80 °C) and +248 °F (+120 °C). Do not exceed the maximum temperature of +302 °F (+150 °C).

Fuel gauge



When you switch on the ignition, the indicator lamp comes on briefly to confirm that the system is operational.

If the indicator lamp comes on and stays on, there are approx. 2.5 gal (10 liters) of fuel still in the tank.

For fuel tank capacity, refer to page 143.

If the tilt of the vehicle varies (when you are driving in mountainous areas, for example), the needle may fluctuate slightly.



Please refuel early, since driving to the last drop of fuel can result in damage to the engine and/or catalytic converter. ◀

Coolant temperature gauge



Blue

The engine is still cold. Drive at moderate engine and vehicle speeds.

Red

Accompanied by the warning, "COOLANT TEMPERATURE" in the Check Control: the engine is overheated. Shut off the engine immediately and allow it to cool down.

To check coolant level, refer to page [118](#).

Between the blue and red zones

Normal operating range. The needle may rise as far as the edge of the red sector in normal operation.

Service Interval Display 65



Green lamps

The number of illuminated lamps decreases as the time for your next maintenance visit approaches.

Yellow lamp

This field appears together with OILSERVICE or INSPECTION. Maintenance is due. Please contact your BMW center for an appointment.

Red lamp

The maintenance deadline has been passed.

66 Check Control



Text messages are used to alert the driver to system malfunctions with the ignition key in position 2 and higher. The alert is accompanied by a gong.

- 1 Status symbol for messages
- 2 Display
- 3 CHECK button

Messages warning of system malfunctions are assigned one of two priority levels.

Priority 1

These defects are immediately indicated by a gong and a flashing warning symbol 1. Simultaneous defects will be displayed consecutively. These status messages remain in the display until the defects are corrected. They cannot be deleted by pressing the CHECK button 3:

- ▷ "RELEASE PARKINGBRAKE"
- ▷ "COOLANT TEMPERATURE"
The coolant is overheated. Stop the vehicle and switch off the engine immediately. Refer to page [117](#)
- ▷ "STOP!ENGINE OILPRESS"
The oil pressure is too low. Stop the vehicle and switch off the engine immediately. Refer to pages [16](#), [115](#)

▷ "CHECK BRAKE FLUID"

The level has dropped nearly to the minimum. Top up the brake fluid at the earliest opportunity. Refer to page [118](#). Have the source of the brake fluid loss diagnosed and corrected at your BMW center

▷ "TIRE DEFECT"

Reduce vehicle speed immediately and stop the vehicle. Avoid hard brake applications. Do not oversteer. Refer to page [83](#)

▷ "LIMIT"*

This is displayed if the programmed speed limit has been exceeded. Refer to page [73](#).

Priority 2

These displays appear for 20 seconds with the ignition key in position 2. The warning symbols remain after the message disappears. The messages can be recalled again with CHECK button 3.

▷ "TRUNKLID OPEN"

This message appears only when you initially begin a trip

▷ "DOOR OPEN"

This message appears after a defined road speed has been exceeded

▷ "FASTEN SEAT BELTS"*

In addition to this message, an indicator lamp with the safety belt icon appears and an acoustic signal is sounded

▷ "WASHER FLUID LOW"

Too low; top up fluid at the next opportunity. Refer to page 115

▷ "CHECK ENGINE OIL LEV"

The oil level is at the absolute minimum, so add engine oil as soon as possible. Refer to page 115. Until then, do not drive more than approx. 30 miles (50 km)

▷ "TIRE PRESSURE SET"

The Flat Tire Monitor has adopted the tires' current inflation pressures as its reference levels. Refer to page 82

▷ "TIRECONTROL INACTIVE"

Transient malfunctions and system errors in the Flat Tire Monitor. Refer to page 83

▷ "CHECK BRAKE LIGHTS"

A lamp has failed or the electrical circuit has a fault. Refer to pages 126 and 132 or consult a BMW center

▷ "CHECK LOWBEAM LIGHTS"

"CHECK SIDE LIGHTS"

"CHECK REAR LIGHTS"

"CHECK FRONT FOGLAMPS"

"CHECK LICPLATE LIGHT"

"CHECK HIGHBEAM LIGHT"

"CHECK BACK UP LIGHTS"

Defective bulb or circuit. Refer to page 124 and following and page 132 or consult a BMW center

▷ "CHECK BRAKE LININGS"

Have the brake pads checked at your BMW center. Refer to page 108

▷ "CHECK COOLANT LEVEL"

The coolant level is too low; top off at the next opportunity. Refer to page 118

▷ "CHECK FILLER CAP"

Check to see whether the fuel filler cap has been properly closed. Refer to page 21

▷ "ENGINE FAILSAFE PROG"

Indicates a malfunction in the electronic engine-management system, which then reverts to an emergency default program allowing continued operation at reduced power and lower engine speeds.

Please have the system inspected by your BMW center

▷ "OUTSIDE TEMPERATURE 24 °F (-5.0 °C)"

This temperature display is only an example. The current temperature is displayed at outside temperatures of 37.5 °F (+3 °C) and below. Refer also to page 63.

Displays after completion of a trip

All of the malfunctions registered during the trip appear consecutively when the key is turned to position 0.

The following displays will appear when appropriate:

▷ "LIGHTS ON"

This display appears when you open the driver's door after parking the vehicle

▷ "KEY IN IGNITION LOCK"

▷ "CHECK ENGINE OIL LEV"

Add the engine oil at the earliest opportunity (next stop to refuel).

Refer to page [115](#).

Status messages remain available for a period of approx. three minutes after the display goes out and the key is removed from the ignition. Press the CHECK button 3 to display these messages. If there were multiple messages, press the CHECK button repeatedly to view them all in sequence.

To check the Check Control

Press the CHECK button 3 with the ignition key in position 2:

CHECK CONTROL OK appears in the display.

There are no faults in the monitored systems.

Computer

You can find descriptions of the computer starting on page [73](#) and in the "Owner's Manual for Onboard Computer."



You can have the Check Control and computer messages displayed in a different language. ◀

Multi-Information Display (MID)

Central Display

The MID serves as the central display and control for the following onboard systems:

- ▷ Digital clock (e.g. time display, date)
- ▷ Audio systems (radio, cassette, CD)
- ▷ Computer (e.g. fuel consumption, cruising range)
- ▷ Cellular phone (e.g. dialing).

You will find explanations and notes for operating the digital clock and the computer on the following pages. Please refer to the Owner's Manual for operating the audio systems, the cellular phone and the onboard computer.

 The system rejects all implausible data entries.

All stored data will be lost if the power supply is interrupted. Time of day, switch-on times for parked-car ventilation, distance and cruise control speed limit may have to be reset once the power supply has been re-established. ◀



- 1 Function button for audio systems
- 2 Function button for the cellular phone*
- 3 Indicator lamp for parked-car ventilation system
 - ▷ remains on if switch-on time is active
 - ▷ flashes while operating
- 4 Function button for the digital clock and computer
- 5 Indicator display for the various onboard systems
- 6 Display for the entry and query buttons. Depending on the operating mode, the functions and alternatives which can be selected at the buttons are displayed here
- 7 Entry and check buttons for operating the various onboard systems

70 Digital clock

 Only make entries when the vehicle is standing still – to avoid endangering yourself or other road users. ◀

Calling up time or date



Press the left side of the button.

Display shows:



You can have the time of day displayed in 12 or 24 hours.

To change the display:



Press the left side of the button.

If the 12-hour time display is in use, AM or PM appears after the time.

Changing the time



Press the left side of the button.



Press the right side of the button:
The dots flash in the display.

To alter the setting:



Press on the left or right, or hold the button down.

To store the entry:



Press the right side of the button.

Changing the date



Press the left side of the button.



Press.



Press the right side of the button:
The dots and the DATE display will flash.

To alter the setting:



Press on left or right, or hold the button down.

To store the entry:



Press the right side of the button.

The clock takes leap years into account and therefore does not have to be reset manually.

Digital clock

Reminder signal

You can program an hourly reminder signal (Memo), that will, for example, remind you of news broadcasts.



Press the left side of the button.



Press:

MEMO OFF appears in the display for entry and query buttons, and the tone symbol will appear in the upper right of the display.

A signal is then heard 15 seconds before each hour.

Stopwatch



Press the left side of the button.



Press.

Display shows:



To start the stopwatch:



Press the right side of the button.

To take an intermediate time reading:



Press.



Press:

The stopwatch display can be seen counting up; the stopwatch continues to run.

To halt the stopwatch:



Press the right side of the button.

 The stopwatch is halted when the ignition key is turned back to 0, but starts to run again when the ignition key is turned to 1. ◀

72 Digital clock

Setting activation times for parked-car ventilation system

You can enter two different activation times.

After 30 minutes, the ventilation will switch off automatically.



Please observe the instructions for operating the parked-car ventilation system on page 92. ◀



Press the left side of the button.



Press on the left or right.

Display shows:



Press the right side of the button:
Display flashes, e.g. TIMER 1.

To enter the time:



Press on left or right, or hold down.

To confirm the entry:



Press the right side of the button.

The activated time is marked with an asterisk.



The switch-on times remain memorized until new entries are made.

You can change switch-on times that have already been memorized by setting a new time using the procedure described above.

When the switch-on time is active, the LED comes on in the MID. During actual operation of the ventilation, the LED flashes. The LED goes out when the system is switched off.

To activate/deactivate the time:



Press twice.

Turning the parked-car ventilation system on and off directly



The parked-car ventilation system is available exclusively in ignition key position 1. ◀



Press the left side of the button.



Press

or



press.

Computer

 Only make entries when the vehicle is standing still – to avoid endangering yourself or other road users. ◀

Computer calculations begin at the start of the journey.

Display information can also be accessed by remote control, refer to page 77.

Speed limit

Speed limit entry:

You can enter the road speed here at which you wish to hear and see a reminder signal: a signal will sound, the word LIMIT will flash and the stored speed will briefly flash in the Check Control display on the instrument cluster.

The speed limit reminder is only repeated if the vehicle has in the meantime been driven at least approx. 3 mph (5 km/h) slower.



Press the right side of the button.



Press.



Press the right side of the button.

Display shows:



Enter the limit by pressing the function buttons.

To correct an entry:



Press the left side of the button and repeat the entry.

To store the entry:



Press the right side of the button.

74 Computer

To adopt the current speed as the speed limit:



Press the right side of the button.



Press.



Press twice at right.

Deactivating the speed limit:



Press the right side of the button.



Press.

The LIMIT display goes out, but the stored limit is not lost and can be re-activated by pressing the LIMIT button.

Distance to destination

The remaining distance to the destination will be displayed on the screen. This is of course only possible if you entered the entire distance before starting the journey.

Enter:



Press the right side of the button.



Press the left side of the button.



Press the right side of the button.

Display shows:



You can enter the distance by pressing the function buttons.

To correct an entry:



Press the left side of the button and repeat the entry.

To store the entry:



Press the right side of the button.

To recall stored value:



Press the right side of the button.



Press the left side of the button.

Computer

Estimated time of arrival

When you have entered the distance from your destination, you can obtain an estimated time of arrival display which is continuously updated by the computer as your average rate of progress varies.



Press the right side of the button.



Press the right side of the button:
The estimated time of arrival is displayed.

Cruising range

The distance which the vehicle should cover on the remaining fuel in the tank is displayed.



Press the right side of the button.



Press:
The display shows the estimated cruising range.



When there is only enough fuel to drive less than 30 miles (50 km), you should refuel, as otherwise the engine or the catalytic converter could be damaged. ◀

The computer will only register fuel amounts over 1.8 gal (6 liters).

Fuel consumption

You can have the average fuel consumption displayed for two different distances, for example a complete journey and part of the journey.

To start the calculation, select the function with the engine running:



Press the right side of the button.



Press on left or right:
The average fuel consumption will be indicated in the display.

To restart the fuel consumption calculation:



Press on the left or right.



Press the right side of the button.

Speed

You can call up a display of the vehicle's average speed.

To start the calculation, select the function with the engine running:



Press the right side of the button.



Press:

The display shows the average speed.

To recalculate the speed:



Press the right side of the button.

Extended immobilizer function

You can define a code that will prevent the engine from being started unless the code is entered.

If you do not have access to the code, the emergency deactivation procedure will have to be carried out, refer to the next page.

To enter and activating the code:



Press the right side of the button.



Press the left side of the button.

Display shows:



Enter the code at the function buttons.

To correct an entry:



Press the left side of the button and repeat the entry.

To store the entry:



Press the right side of the button.
Turn the ignition key to position 0.

Deactivate the code:

When you are asked to enter the code (ignition key in position 1 or 2):

▷ Enter the code at the function buttons



Press the right side of the button.

After the code has been entered correctly and confirmed with the SET button, the time display appears.

Computer

After three incorrect code entries, or three attempts to start the engine without a code entry, the alarm will sound for 30 seconds on vehicles equipped with an alarm system.

Setting the alarm in an emergency:

If you have forgotten the code, proceed as follows:

1. Disconnect the battery, wait about 2 minutes, then reconnect it. Note that on vehicles with an alarm system, the alarm will sound
2. Turn the ignition key to position 1: The time display will count down for the next ten minutes
3. After ten minutes, start the engine.

 If the code becomes available again in the meantime, it can be entered during the waiting period after pressing the CODE button. ◀



Remote control

You can press the button in the turn signal indicator lever to retrieve information from the computer for display.

To do this, press:

- ▷ The button on the lever until PROG 1 shows on the display
- ▷ The MID buttons in the order in which you wish the information to be displayed.

Each time an entry is stored, the program number appears on the display.

To terminate the selection procedure:



Press the right side of the button.

To display all the available information, press:

- ▷ The button on the lever until the display shows PROG 1
- ▷ The SET button.

To obtain individual items of information, press the button in briefly as often as necessary.

The concept

PDC provides extra safety and convenience during parking maneuvers by providing an acoustic signal to indicate the distance to the nearest object. To do this, four ultrasonic sensors in the front and rear bumpers each measure the distance to the nearest object. The monitoring range of the front sensors and two rear sensors at the ends of the rear bumper extends outward roughly 2 ft (60 cm), while the rear bumper's two centrally located sensors detect objects at distances of up to approx. 5 ft (1.50 m).

Automatic function

The system is activated automatically about one second after you engage reverse with the ignition key in position 2.



Manual activation

Press the button, the indicator lamp lights up.

When you subsequently drive a distance of more than approx. 160 ft (50 meters) or exceed a speed of approx. 20 mph (30 km/h), the system switches off and the indicator lamp goes out. Switch the system on again as required.

Manual deactivation

Press the button again.

Acoustic signals

The distance from an obstacle is indicated in front with a higher intermittent tone, at the rear with a lower intermittent tone. As the distance between vehicle and object decreases, the intervals between the tones become shorter. A continuous tone indicates the presence of an object less than 1 ft (30 cm) away.

The warning signal is canceled after approx. three seconds if you are moving parallel to a wall.

If there is a malfunction of the system: The indicator lamp flashes and a brief continuous signal tone is heard

- ▷ when you activate PDC with the button
- ▷ when you select reverse for the first time after switching on the ignition
- ▷ if a malfunction occurs while the PDC system is active.

Switch the system off and have the cause of the malfunction corrected by your BMW center.

Park Distance Control (PDC)*

 PDC does not remove the driver's personal responsibility for evaluating the distance between the vehicle and any obstacles. Even with the sensors, there is a blind spot in which objects cannot be detected. This applies especially in those cases where the system approaches the physical limits of ultrasonic measurement, as occurs with e. g. tow bars and trailer couplings, and in the vicinity of thin or wedge-shaped objects. Certain sources of sound, such as a loud radio, could drown out the PDC signal tone. ◀

 Keep the sensors clean and free of ice or snow in order to ensure that they will continue to operate effectively. Do not apply high-pressure spray to the sensors for a prolonged period of time. Maintain an adequate distance of more than 4 in (10 cm). ◀

80 Dynamic Stability Control (DSC)

DSC maintains vehicle stability, even in critical driving situations.

The system optimizes vehicle stability during acceleration and when starting from a full stop, as well as enhancing traction. In addition, the system recognizes unstable vehicle conditions (understeering or oversteering, for example) and holds the vehicle on a sure course by intervening via the engine and by braking at the individual wheels.

The system starts up automatically each time you start the engine.

Indicator lamp



The indicator lamp in the instrument cluster goes out shortly after you switch on the ignition.

Refer to page 17.

Indicator lamp flashes:

The system is active and governs drive and braking force.

If the indicator lamp fails to go out after the engine is started, or if it comes on during normal driving and stays on:

There is a system malfunction or the system was deactivated with the button. You can continue to drive the vehicle normally, but without DSC. Please consult your BMW center for repairs.



To deactivate the system

Press the button, the indicator lamp lights up and remains on continuously.

When DSC is deactivated, you are driving with conventional power transfer.

In the following exceptional circumstances, it may be effective to deactivate the DSC for a short period:

- ▷ When rocking the vehicle or starting off in deep snow or on loose surfaces
- ▷ When driving with snow chains.

To reactivate the system

Press the button again; the indicator lamp goes out.



The laws of physics cannot be repealed, even with DSC. An appropriate driving style always remains the responsibility of the driver. Do not use the extra safety margins furnished by these systems as an excuse for taking unnecessary risks. ◀

Dynamic Brake Control (DBC)

DBC is an integral component of the DSC system.

The system responds to sudden, high-intensity applications of force to the brake pedal by automatically braking the vehicle with maximum boost to achieve the shortest possible braking distances during "panic stops." This system exploits all the benefits of ABS.

Do not reduce the pressure exerted against the brake pedal until the braking maneuver has been completed. DBC is deactivated when you release the pedal.



Performance Recognition

Press the button with the ignition key in position 2: the indicator lamp comes on.

Deactivating Performance Recognition: Press the button again; the indicator lamp goes out.

The coordinated performance-comfort mode is activated automatically each time you start the engine.

The system guarantees that whenever desired, the system will switch the Servotronic and the accelerator pedal response from the sporty-comfortable mode to a pure performance mode. This means that steering response becomes more performance-oriented and the response of the accelerator pedal is much more spontaneous (Performance Recognition).

82 Flat Tire Monitor

The concept

The Flat Tire Monitor keeps track of the inflation pressures in your tires as you drive. The system provides an alert whenever the inflation pressure drops significantly in one of the tires.

To initialize the Flat Tire Monitor system with the correct tire inflation pressures, start by checking the inflation pressures in all four tires, comparing them with the figures specified in the tire inflation pressure table (page 23). Then correct the tire inflation pressures as necessary. Now you can activate the system.

The Check Control (refer to page 66) will inform you if the tire inflation pressure of one of the tires has dropped significantly.



Activating the system

1. Turn the ignition key to position 2 (do not start the engine)
2. Press the button and maintain pressure until the message "SET TIRE PRESSURE" appears in the Check Control (several seconds)
3. As you drive, the Flat Tire Monitor automatically enters the system initialization mode in which it stores the current pressures as its reference figures. The initialization process lasts for ten minutes or somewhat longer. Once it has been completed the Tire Pressure Monitor is able to detect and warn of flat tires.

Repeat this process after altering the tire inflation pressure, changing the tire, or rotating the wheels.

Do not carry out a new initialization of the system, if you correct the inflation pressures to the already specified tire pressures.

Flat Tire Monitor

Flat tire

In the event of a flat tire, the message, "TIRE DEFECT" will appear in the Check Control. This visual alert will be accompanied by a gong.

If this occurs, reduce vehicle speed immediately and stop the vehicle. Avoid hard braking and overcorrecting at the steering wheel.

Correct the flat tire using the M Mobility system (refer to page [128](#)).



The Flat Tire Monitor cannot alert you to severe and sudden tire damage caused by external factors. Another factor which the Flat Tire Monitor does not recognize is the balanced and very gradual pressure loss that takes place in all tires over an extended period of time. ◀



Check the tire inflation pressure on a regular basis and correct if necessary. Refer to page [22](#).

Do not carry out any kind of system activation when using snow chains. Under these kinds of conditions, false warnings and unidentified losses in pressure are possible.

In certain circumstances, when driving on snow-covered or slippery road surfaces, there may be a delay in identifying any loss in inflation pressure. Performance-oriented driving (slip at the drive wheels, high levels of lateral acceleration) can also delay the appearance of status messages in the Flat Tire Monitor's display panel. ◀

System malfunctions

The message "TIRECONTROL INACTIVE" appears in the Check Control and remains on until the problem is corrected.

The same message is displayed if there is a system malfunction.

Please refer the problem to your BMW center.



Parking lamps (side marker lamps)



With the switch in this position, the front, rear and side vehicle lighting is switched on.

For lighting on one side for parking as an additional feature, refer to page 85.

Low beams



When you switch off the ignition and the low beams are still on, only the parking lamps (side marker lamps) remain on.



"Follow me home":

When you activate the headlamp flasher after parking the vehicle and switching off the lights, the low beams will come on for a brief period. You may also have this function deactivated if you wish. ◀

"LIGHTS ON" warning

When the driver's door is opened with the ignition key in position 0 a message will appear in the Check Control if the lights are on, refer to page 68.

Daytime driving lamps*

The headlamps are automatically switched on for daylight driving at ignition key position 2.

Automatic headlight control*



When the switch is set to this position the system automatically activates and cancels the low beams in response to changes in ambient light (in tunnels, at dusk, etc.) as well as rain and snow.



The vehicle's external lights remain on constantly when you switch on the front fog lamps after the headlights have come on automatically. ◀



Automatic headlight control cannot serve as a substitute for the driver's judgement in determining when the vehicle lights should be switched on. For example, the sensors are not able to detect fog. To avoid safety risks, you should respond to these kinds of low-visibility situations by switching the headlights on manually. ◀



You can have the sensitivity of your vehicle's automatic headlight control adjusted. ◀



Turn the rotary dial to adjust the illumination intensity.



- 1 High beams (blue indicator lamp)
- 2 Headlamp flasher (blue indicator lamp)
- 3 Standing lamps

Standing lamps, left or right

As an additional feature, you can illuminate your vehicle on either side for parking, if you wish to do so:

With the ignition key in position 0, push the lever in the appropriate direction. The lever engages in the turn signal indicator position.



Front fog lamps



The green indicator lamp in the instrument cluster lights up to indicate that the front fog lamps are on.

If the high beams are switched on, the fog lamps go out.

Always comply with the legal regulations governing use of fog lamps.



If the automatic headlight control is on, the low beams will come on automatically whenever you activate the fog lamps. ◀

86 Interior lamps



The interior lamps operate automatically.

Switching the interior lamps on and off manually

Press the button (arrow) briefly.

If you want the interior lamps to remain off all the time, press and hold the button for approx. 3 seconds.

To revert to normal operation, press the button briefly.

Reading lamps



Reading lamps are located in the front near the interior lamp or in the rear of the vehicle. They can be switched on and off with the button (arrow) adjacent to each lamp.

 In order to prevent battery discharge, all of the lamps in the vehicle are switched off automatically approx. 15 minutes after the ignition key is turned to position 0. ◀

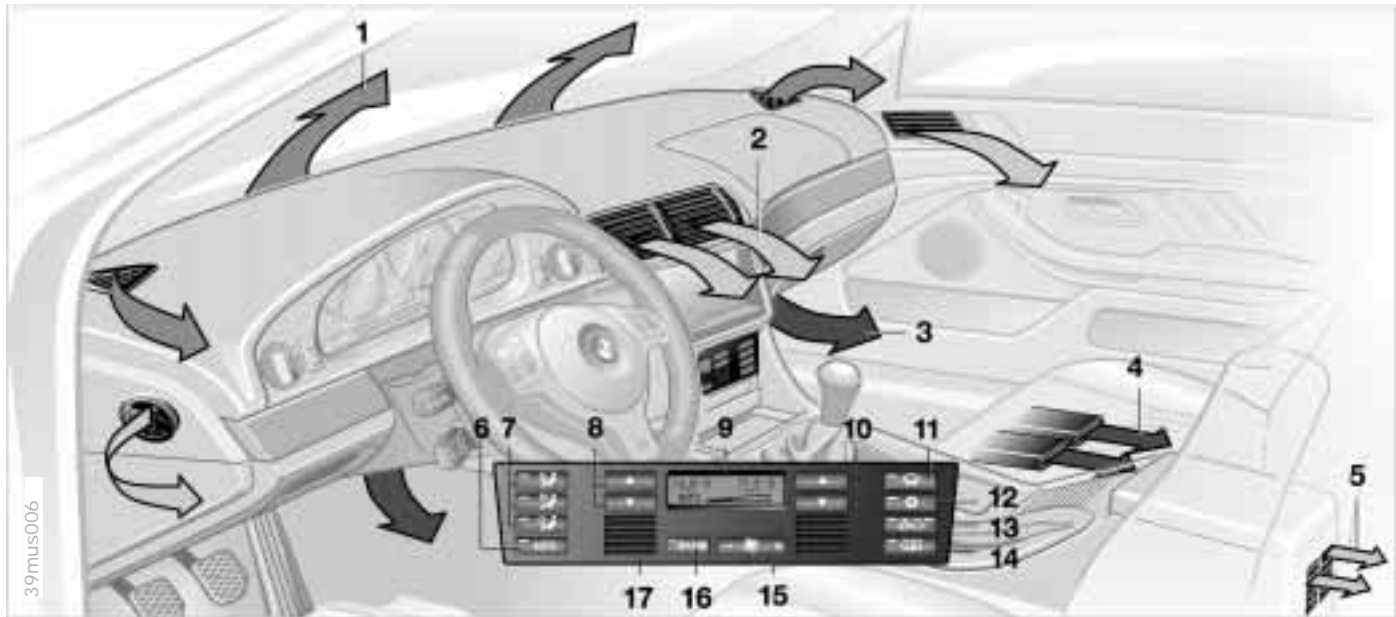

39mus006

- 1 Airflow directed toward the windshield and side windows
- 2 Airflow for the upper body area [91](#)
- 3 Footwell ventilation

- 4 Rear footwell ventilation
- 5 Airflow for the upper body area in the rear seats [91](#)
- 6 Automatic air distribution [89](#)

- 7 Individual air distribution [89](#)
- 8 Temperature control – left-hand side [89](#)
- 9 Display for temperature and air supply [89](#)

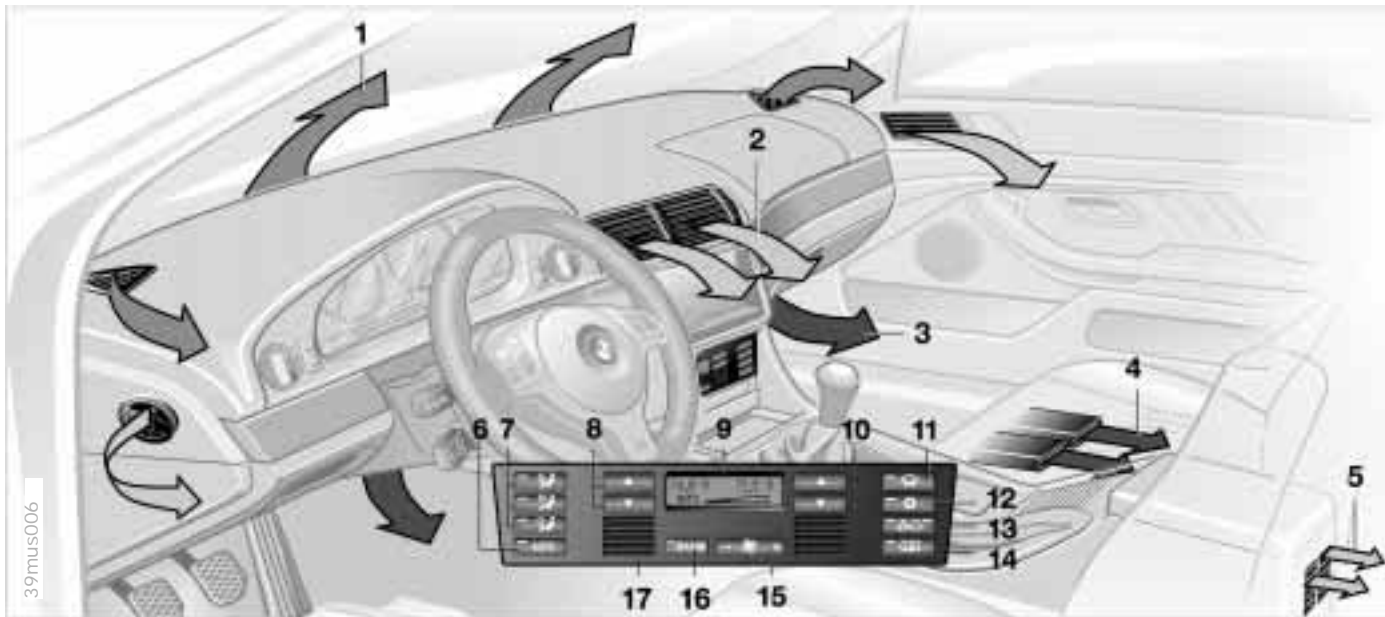

- 10 Temperature control – right-hand side [89](#)
- 11 Defrost windows and remove condensation [89](#)
- 12 Air conditioning [90](#)

- 13 Automatic recirculated-air control (AUC) [90](#)
- 14 Rear window defroster [90](#)
- 15 Air supply [89](#)

- 16 Maximum cooling [90](#) or residual heat mode [90](#)
- 17 Air grill for interior temperature sensor – please keep clear and unobstructed

Automatic climate control

Tips for pleasant driving

Use the automatic system (switch on with AUTO button 6). Select an interior temperature that you find comfortable. The following description will lead you through additional individual settings.



Your BMW center can program the settings of your vehicle in such a manner that, when you unlock the vehicle with your individualized key, your own personalized setting for the automatic climate control is initiated. ◀



Automatic air distribution



The AUTO program assumes the adjustment of the air distribution and the air supply for you and – in addition to that – adapts the temperature to external influences (summer, winter) to meet preferences you can specify.

Individual air distribution



You also have the option of individually configuring the air distribution pattern to suit your own personal preferences. While the AUTO program is then deactivated, the automatic airflow control remains in operation. The system directs air to the windows , the upper body  and into the footwells . You can reactivate the automatic air distribution mode by selecting the AUTO button.

Temperature



You can make individual temperature settings on the driver's side or the front passenger side. The figures in the display provide a general indication of interior temperature. We recommend a setting of 72 °F (22 °C) for a congenial interior climate, even when the air conditioner is in operation. When you start the vehicle, the system ensures that the selected temperature is achieved as quickly as possible. It then maintains this temperature, regardless of the season.

Air supply



In the AUTO program, the airflow is controlled automatically. AUTO will appear in display 9, refer to the overview on page 87. Use "+" and "-" to vary the airflow. Your setting is displayed with bars and the automatic air supply is switched off. The automatic air distribution setting is maintained. You can reactivate the automatic air supply by pressing the AUTO button.

When you press "-" during operation at the lowest blower speed, all displays are canceled: the blower, heating and air conditioning are switched off. The outside air supply is deactivated. By pressing the desired button on the automatic climate control (except MAX button 16), you can switch the system back on.

To defrost windows and remove condensation



This program quickly removes ice and condensation from the windshield and the side windows.

Air conditioning

The air is cooled and dehumidified and – depending on the temperature setting – warmed again when the air conditioning is switched on.

Depending on the weather, the windshield may fog over briefly when the engine is started. You can reduce condensation forming on the windows by switching on the air conditioning.



Condensation forms in the air condition system during operation, which then exits under the vehicle. Traces of condensed water of this kind are thus normal. ◀

Maximum cooling

At outside temperatures above roughly 41 °F (5 °C) this program furnishes maximum cooling whenever the engine is running.

The temperature displays 9 jump to 60 °F (16 °C), the system reverts to operating in the recirculated-air mode and maximum airflow emerges from the vent outlets only. That is why you need to keep these open if you select this program.

Automatic recirculated-air control

You can respond to unpleasant external odors by temporarily excluding the flow of outside air. The system then recirculates the air currently within the vehicle. By repeated actuations of the button, you can select one of three different operation modes.

- ▷ Indicator lamps off: outside airflow operational
- ▷ Left-hand indicator lamp on – AUC mode: the system recognizes pollutants in the outside air and blocks the flow of air when necessary. The system then recirculates the air currently within the vehicle.

Depending on the air quality, the automatic system then switches back and forth between outside air supply and recirculation of the air within the vehicle

- ▷ Right indicator lamp on – recirculated-air mode: the flow of external air into the vehicle is permanently blocked. The system then recirculates the air currently within the vehicle.



If the windows should fog over in the recirculated-air mode, switch it off and increase the air supply as required. ◀

Rear window defroster

When the rear window defroster is activated, the indicator lamp comes on. The rear window defroster switches off automatically.

Residual heating mode

The heat which is stored in the engine is utilized for heating the interior when the engine has been switched off (while waiting at a railroad crossing, for instance). In ignition key position 1, you can alter the settings of the automatic climate control. With the ignition key in position 0, the system automatically directs heated air to the windshield, side windows and footwells.



This function is available for operation when the outside temperature is below approx. 59 °F (15 °C), with the engine warm from recent operation and an adequate charge in the battery. The LED on the button will light up when all conditions have been met. ◀

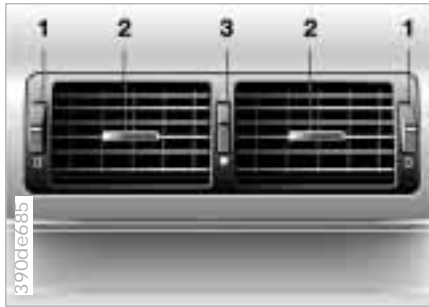

Draft-free ventilation

You can adjust the vent outlets for the upper body area for optimal personal comfort:

- 1 Rotary dials for infinitely-variable opening and closing of the vent outlets
- 2 Rotary levers for airflow direction
- 3 Rotary dial allows you to control the temperature of the airflow as desired:
 - ▷ Turn toward blue – colder
 - ▷ Turn toward red – warmer.

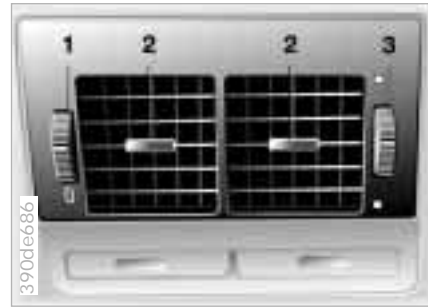

Rear passenger area ventilation

- 1 Rotary dial for infinitely variable opening and closing of vent outlets
- 2 Rotary levers for airflow direction
- 3 The rotary dial operates in the same way as the front dial to adjust the temperature of the emerging air.

Microfilter, activated-charcoal filter

The microfilter removes dust and pollen from the incoming air. The activated-charcoal filter provides additional protection by filtering gaseous pollutants from the outside air. Your BMW center replaces this combined filter as a standard part of your scheduled maintenance. A substantial reduction in airflow indicates that the filter must be replaced before scheduled maintenance.



To actuate, press the button briefly with ignition key in position 1.

Roller sun blinds for rear side windows*

Use the strap to pull out the blinds, then hook them in the provided attachment.

Parked-car ventilation

It will ventilate the interior, reducing the temperature through the use of the automatic climate control blowers, whenever the vehicle is not in operation.

The parked-car ventilation system is operated via the Multi-Information Display (MID) – refer to page 72 – or the onboard computer. Refer to the "Owner's Manual for Onboard Computer."

You may preselect two different activation times. The ventilation will remain activated for 30 minutes. You can also turn it on and off directly. Since the system uses a substantial amount of electrical current, you should refrain from activating it twice in succession without allowing the battery to be recharged in normal operation between use.

The parked-car ventilation is available for timer-controlled operation whenever outside temperatures exceed 60 °F (16 °C), and can also be activated manually at any temperature. It operates only when the vehicle is stationary.

The air emerges via the vent outlets for the upper body. Therefore, the vent outlets must be open for the system to operate.

You can adjust the airflow volume and the air distribution when the ignition key is in position 1.

The concept

The BMW Universal Transmitter replaces up to 3 hand-held transmitters, e.g. for garage-door openers, alarm systems or a door-locking system. The BMW Universal Transmitter recognizes and "learns" the signal transmitted from each of the original hand-held transmitters.

The signal of an original hand-held transmitter can be programmed to one of the three channel keys. Following that, each of the devices can be actuated with the appropriately-programmed channel key. The indicator lamp flashes to confirm transmission of the signal.

Before you sell your vehicle, the program data in the channel keys should be deleted. Refer to page 95 for the description of this process.

 To prevent potential injuries or damage: during the programming operation and before every remote triggering of a programmed device using the BMW Universal Transmitter, be sure that there are no persons, animals or objects within the range of movement of the respective device. Read and comply

with the safety instructions for the original hand-held transmitter also. ◀



To Canadian residents
During programming, your hand-held transmitter may automatically stop transmitting after two seconds. This may not be long enough to program the BMW Universal Transmitter. If you are programming from one of these hand-held transmitters, the BMW Universal Transmitter's light may begin to flash in a series of double-blinks. If this occurs, continue to hold the key on the BMW Universal Transmitter while you reactivate your hand-held transmitter. You may have to repeat this function several times while programming. ◀



Before programming, read the "User's information" section on page 95. ◀

The original hand-held transmitter



If this symbol is depicted on the packaging or in the user's instructions for the original hand-held transmitter, it may be assumed that this original hand-held transmitter is compatible with the BMW Universal Transmitter.

Checking for the conversion code

In order to determine whether the original hand-held transmitter is equipped with a conversion code system, you may either refer to the instructions for the original hand-held transmitter or program a channel key as described in the left-hand column on page 94 under "Programming."

Following that, press and hold the programmed channel key on the BMW Universal Transmitter. If the indicator lamp on the BMW Universal Transmitter flashes rapidly for two seconds and then stays on continuously, the original hand-held transmitter is equipped with a conversion code system. If the conversion code system is available, program the channel keys as described on page 94 in the right-hand column under "Programming a hand-held transmitter with conversion code."



If you have additional questions, please consult your BMW center or call 1-800-355-3515. ◀

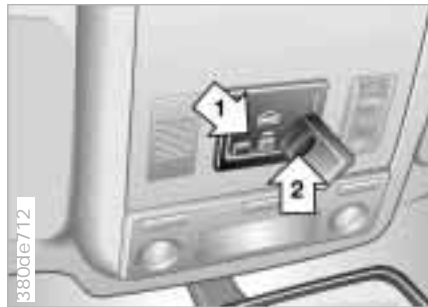
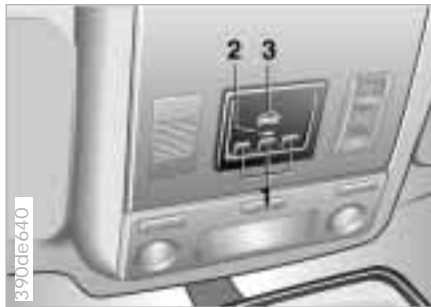

Programming

- 1 Channel keys
- 2 Indicator lamp
- 3 Receiver for programming

 Read and comply with the safety precautions on page 93. ◀

1. Ignition key in position 2
2. For initial operation: press and hold the two outer keys 1 until the indicator lamp 2 flashes. Release the keys. The three channel keys are cleared

3. Hold the original hand-held transmitter to receiver 3, a maximum of 2 in (5 cm) away
 4. Press the transmitting key on the original hand-held transmitter (arrow 2) and the desired channel key on the BMW Universal Transmitter (arrow 1) at the same time. Release both keys as soon as the indicator lamp flashes rapidly
 5. To program other original hand-held transmitters, repeat steps 3 and 4.
- The selected channel key is now programmed with the signal of the original hand-held transmitter.

Programming a hand-held transmitter with conversion code

 Read and comply with the safety precautions on page 93. ◀

Consult the operating instructions when programming the BMW Universal Transmitter for a particular device. Read and comply with the following programming instructions to use the BMW Universal Transmitter with a conversion code system:

 A second person simplifies programming of the BMW Universal Transmitter. ◀

1. Program the BMW Universal Transmitter as described on the previous page under "Programming"
2. Press and hold the programming key on the receiver of the device for about two seconds or until the programming lamp on the device comes on
3. Press the desired channel key on the BMW Universal Transmitter three times.



If you have additional questions, please consult your BMW center or call 1-800-355-3515. ◀

Deleting the channel keys



Read and comply with the safety precautions on page 93. ◀

Individual channel keys cannot be deleted. However, the three channel keys can be deleted together in the following manner:

- ▷ Press and hold the two outside channel keys on the BMW Universal Transmitter until the indicator lamp flashes, then release the keys.

All channel keys are deleted.

User's information

Do not use this BMW Universal Transmitter with any garage-door opener that lacks safety "stop" and "reverse" features as required by federal safety standards, (this includes any garage-door opener model manufactured before April 1st, 1982).

This device complies with Part 15 of the FCC Rules. Operation is subject to the following two conditions: (1) This device may not cause harmful interference, and (2) This device must accept any interference received, including interference that may cause undesired operation.



To open

Pull the handle and the lamp comes on.

To close

Fold the cover up.

 To prevent injury in the event of an accident, close the glove compartment immediately after use. ◀

To lock

Use one of the master keys to lock the vehicle. A master key is also required for unlocking.

 If you turn over only your door and ignition key for valet parking, for example (refer to page 26), access to the glove compartment is not possible. ◀

Rechargeable flashlight*

Located on the left-hand side of the glove compartment. Features integral overload-protection, so it can be left in its holder continuously.

 To avoid completely discharging and possibly damaging the lamp, always ensure that the flashlight is switched off before inserting it in the socket. ◀



You can open and close the cover for the center console's storage compartment by pushing on the slanted front part (arrow). If your vehicle is equipped with a cassette holder*, open each cassette compartment by pressing the small button.

Storage compartment on the center console between the front seats: to open, reach into the recess at the front and pull upward. If a cellular phone has been installed, this compartment is occupied by the phone.

You will find additional storage compartments in all of the doors as well as in the backrests of the front seats*.

Cellular phone*



Hands-free system*

For vehicles with a telephone preparation*, the trim cover for the hands-free speaker is located in the headliner in the area the interior lamp.

For further information on the cellular phone: refer to the Supplementary Owner's Manual.

Beverage holder*



Two holders for canned drinks have been provided in the front center console (illustration).

Press to open; fold back inward to close.

Ashtray, front*



To empty

Press the edge of the lid (arrow): you can now pull the ashtray upward for removal.

On vehicles equipped with a non-smoker's package, the insert is removed in the same way.

98 Cigarette lighter*



Press the cover panel for access (arrow), then push down the lighter.

Remove as soon as the lighter jumps back out.



Hold or touch the hot cigarette lighter by the knob only. Holding or touching it in other areas could result in burns.

The cigarette lighter remains operational when the ignition key has been removed. For this reason, children should never be left in the vehicle unattended. ◀

Ashtray, rear*

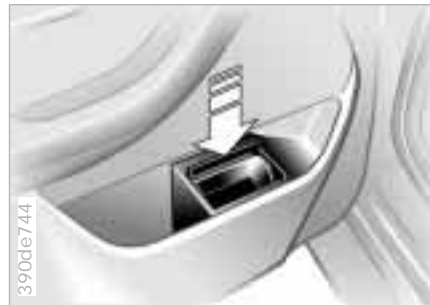

To empty

Press the edge of the cover (arrow): you can now pull the ashtray upward for removal.

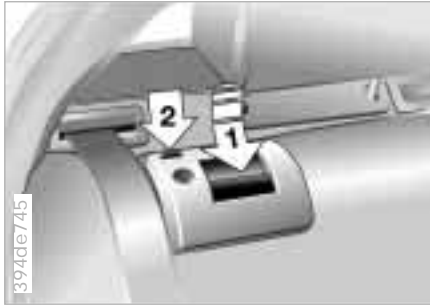

Fold the rear backrests down

Reach into the recess and pull forward (arrow 1).

When you close the backrest, be sure that the catch engages securely. The red slide (arrow 2) must retract completely.

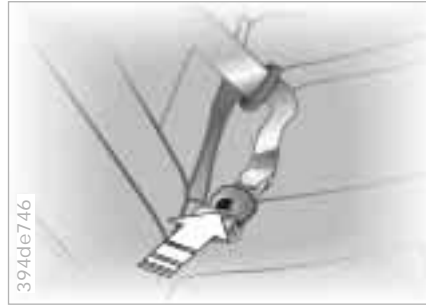

The central belt has an additional small buckle.

- ▷ If you connect the two belt sections, you can use the central belt as any normal 3-point belt
- ▷ It is easier to fold the rear-seat backrest up and down if you disconnect the belt (arrow).

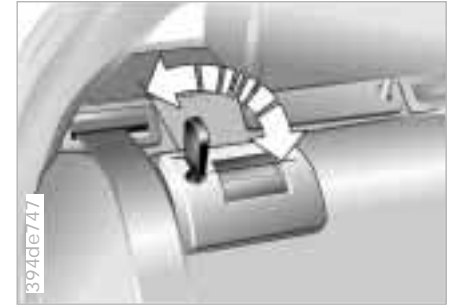

With a master key you can lock each backrest in the rear seat.

This also prevents access to the luggage compartment from the interior of the vehicle if you turn over only your door and ignition key 3 (refer to page 26). This is convenient for valet parking, for instance.

100 Ski bag*

The ski bag allows the safe and clean transport of up to four pairs of standard skis or up to two snowboards.

The length of the ski bag and the additional space provided in the luggage compartment make it possible to carry skis with a length of up to 6.8 ft (2.10 meters). Because of the tapered shape of the bag, the ski bag can only accommodate two pairs of skis with a length of 6.8 ft (2.10 meters).



Installing the center armrest

Guide the armrest into position from above, then apply pressure until you hear it snap into position.



Be sure that the seat covers are not damaged by the side pins. ◀

Removing the center armrest

(Not for vehicles with the through-loading system, refer to page 102).

1. Fold the center armrest completely outward
2. Loosen the trim from the upper Velcro® fastener and place it on the armrest
3. Grasp the front of the armrest with one hand, then use your other hand to reach down behind the armrest and pull up sharply (arrow).

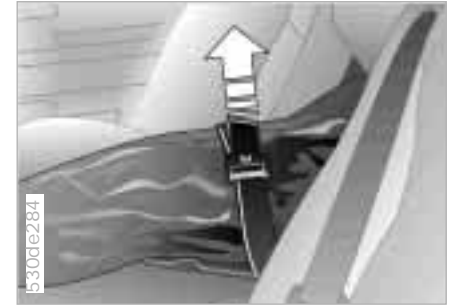

Loading

1. Press the release button (arrow 1): the cover panel in the luggage compartment is unlocked
2. Press the detent levers (arrows 2) inward and fold the cover to the front seats.
3. Extend the ski bag between the front seats. The zipper provides convenient access to stored items. It may be opened to allow the ski bag to dry

4. Use the magnetic retainers to attach the cover panel to the upper surface (metal surface below rear tray) of the luggage compartment.

To store the ski bag, perform the above steps in reverse sequence.



An unsecured ski bag could lead to loss of vehicle control and in case of an accident to personal injury. ◀

Securing the load



Secure the bag's contents by tightening down the retaining strap at the buckle. ◀

Please be sure that the skis are clean before loading them into the bag. Be careful to avoid damage from sharp edges.

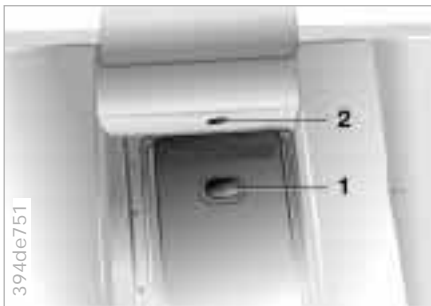

With through-loading system

1. Fold the center armrest outward. Loosen the trim from the upper Velcro® fastener and place it on the armrest
2. Press button 1 downward and swing the cover forward
3. Press knob 2: the cover in the luggage compartment is unlocked.

Cargo loading

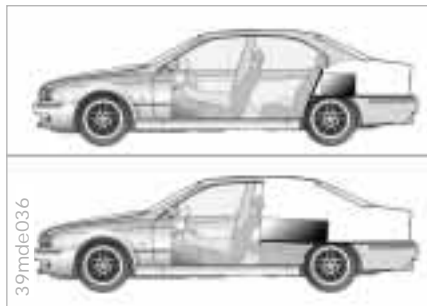

Stowing cargo

When transporting cargo in your BMW:

- ▷ Load heavy cargo as far forward as possible – directly behind the backrests or the luggage compartment partition – and as low as possible
- ▷ Cover sharp edges and corners
- ▷ Do not pile objects higher than the top edge of the backrest
- ▷ If you are transporting very heavy loads when the rear seat is not occupied, secure the outer safety belts in the opposite buckles.



Securing the load

- ▷ Secure smaller, light pieces with the luggage net or use retaining straps* (refer to page 34)
- ▷ For large, heavy pieces, see your BMW center for load-securing devices*. The lashing eyes provided at the corners of the luggage compartment serve for mounting these load-securing devices
- ▷ Comply with the information enclosed with the load-securing devices.

 Always position and secure the load correctly. If you do not, it can endanger the passengers during braking or evasive maneuvers. Never exceed either the approved gross vehicle weight or the approved loads for either of the axles (refer to page 142), as overloading the vehicle beyond the legally approved levels can severely compromise its operating safety.

Do not carry hard or heavy objects unsecured in the passenger compartment. If you do so, they may be projected through the air during braking and evasive maneuvers, thus endangering vehicle occupants. ◀



A special roof-rack system is available as an optional extra for your BMW. Please observe the precautions included with the installation instructions.

Anchorage

Access to the anchorages:
To fold up the cover (arrow), please use the tool provided with the roof-rack system.

Loading and driving notes

Roof-mounted luggage racks raise the center of gravity of the vehicle when they are loaded. For this reason, they have a major effect on the vehicle's handling and steering response.

You should therefore always remember not to exceed the approved roof load capacity, the approved gross vehicle weight or the axle weights when loading the rack. These weights are listed under "Technical Data", page 142.

Make sure that the load is not too bulky, and attempt to distribute it evenly. Always load the heaviest pieces first (on the bottom). Be sure that adequate clearance is maintained for raising the sliding/tilt sunroof.

 Secure the roof luggage correctly and securely to prevent it from shifting or being lost during driving (danger to following traffic). ◀

Drive smoothly and avoid sudden acceleration and braking. Do not corner at high speeds.



Overview

Controls and features

Operation, maintenance

Owner service procedures

Technical data

Index



Overview
Controls
Maintenance
Repairs
Data
Index

To ensure that your vehicle provides maximum economy throughout a long service life, we request that you observe the following.



Your BMW M5 is a masterpiece of superlative technology. To ensure that you derive maximum satisfaction from its extensive array of advanced features while simultaneously creating the basis for many years of driving pleasure, we urge you to observe the following precautions during the initial period of operation. ◀

Engine and differential

Up to 1,200 miles (2,000 km):
Drive at varying engine speeds and road speeds, but do not exceed 5,500 rpm or 105 mph (170 km/h) during this period.

Comply with all official speed limits.

Do not depress the accelerator pedal to the full-throttle position.

Following the Break-in inspection at 1,200 miles (2,000 km), you can gradually increase engine or road speeds.

You should also comply with these break-in procedures if the engine or differential is replaced later in the course of the vehicle service life.

Tires

Owing to technical factors associated with their manufacture, tires do not achieve their full traction potential until an initial break-in period has elapsed. Thus drive with extra care during the initial 200 miles (300 km).

Comply with all official speed limits.



When the vehicle is operated on wet or slushy roads, a wedge of water may form between the tire and the road surface. This phenomenon is referred to as aquaplaning, or hydroplaning, and can lead to partial or complete loss of traction, vehicle control and braking effectiveness. Reduce your speed on wet roads. ◀

Brake system

Approximately 300 miles (500 km) must elapse before the brake pads and rotors achieve the optimal pad-surface and wear patterns required for trouble-free operation and long service life later on.

To break-in the separate parking brake drums, apply the parking brake lightly when coasting to a standstill (at a traffic signal, for instance), provided that traffic conditions allow you to do so. To avoid corrosion, repeat this procedure from time to time.



The brake lamps do not come on when the parking brake is applied. Vacuum for the brake system servo unit on your BMW is available only when the engine is running. When you move the vehicle with the engine shut off – when towing, for instance – substantially higher levels of pedal force will be required to brake the vehicle. ◀

Clutch

The clutch will also begin to function optimally after about 300 miles (500 km). Engage the gears carefully during the break-in period.



Brakes:

Do not rest your foot on the brake pedal while driving. Even light but consistent pedal pressure can lead to high temperatures, brake wear and possibly even brake failure.

Hydroplaning:

When driving on wet or slushy roads, reduce vehicle speed. If you do not, a wedge of water may form between the tires and the road surface. This phenomenon is referred to as aquaplaning, or hydroplaning, and can lead to partial or complete loss of traction, vehicle control and braking effectiveness.

Driving through water:

When there is water on the roads, do not drive in it if it is deeper than 1 ft (30 cm). If the water is at that depth, drive only at walking speed, otherwise the vehicle can sustain damage to the engine, the electrical systems and the transmission.

Rear parcel tray:

Do not place heavy or hard objects on the rear parcel tray. If you do so, they could pose a danger to vehicle occupants during a braking or evasive maneuver.

Clothes hooks:

When suspending clothing from the hooks, ensure that they will not obstruct the driver's vision. Do not hang any heavy objects on the hooks, otherwise, passengers could be injured e.g. during any hard braking or evasive maneuvers, or during an accident. ◀

The concept

The Antilock Brake System (ABS) keeps the wheels from locking during braking, thereby enhancing active driving safety.

With ABS, the shortest possible braking distances are achieved under most conditions (on straight-aways and in curves, on asphalt, ice, wet road surfaces, etc.).

Braking with ABS

If you are in a situation that requires full braking, you will exploit the full benefits of the ABS system if you apply maximum pedal pressure ("panic stop").

Pulsation at the brake pedal combined with sounds from the hydraulic circuits indicates to the driver that ABS is in its active mode.

Brake fluid level

If the brake fluid level is too low and brake pedal travel has become noticeably longer, there may be a defect in one of the two brake system's hydraulic circuits.

 Proceed to the nearest BMW center. Higher brake application pressure may be necessary under these conditions, and the vehicle may exhibit a slight tendency to pull to one side when the brakes are applied. Braking distances may also be longer. Please remember to adapt your driving style accordingly. ◀

Disc brakes

Limited vehicle use, extended periods with the vehicle parked or in storage, and operating conditions in which braking is restricted to gentle, low-pressure applications will all increase the tendency for corrosion to form on the rotors; this is often accompanied by a simultaneous accumulation of contamination on the brake pads. The pads must exert a certain minimal level of pressure against the rotors for the disc brakes' inherent self-cleaning effect to remain effective; the pressure available under the above conditions may not provide adequate cleansing.

If the brake rotors are corroded, they will tend to respond to braking with a pulsating effect that even extended brake applications will fail to cure.

When driving in heavy rain and on wet roads it is a good idea to apply light pressure to the brake pedal every few miles. Monitor traffic conditions to ensure that this maneuver does not pose a hazard to you or to other road users. The heat generated in this process helps dry the pads and rotors to ensure that your brake system will respond with undiminished efficiency when you need it.

When descending steep hills and extended grades, downshift to a gear that will allow you to continue safely with only a minimal amount of braking. By minimizing the loads placed on the brake system, this strategy helps ensure that optimal brake system response will remain available at all times.

 Do not coast with the clutch depressed or with the transmission or gearshift lever in Neutral. Do not coast with the engine shut off. The engine provides no braking effect when the clutch is depressed and there is no power-assist for braking or steering when the engine is not running. Never allow floor mats, carpets or any other objects to protrude into the area around the accelerator, clutch and brake pedals and obstruct their movement. ◀

Brake pads

 For your own safety: use only brake pads that BMW has approved for your particular vehicle model. BMW cannot evaluate non-approved brake pads to determine if they are suited for use, and therefore cannot ensure the operating safety of the vehicle if they are installed. ◀

Tire inflation pressure

Information for your safety

The factory-approved radial tires are matched to the vehicle and have been selected to provide optimum safety and driving comfort on your vehicle.

It is not merely the tire's service life, but also driving comfort and – above all else – driving safety that depend on the condition of the tires and the maintenance of the specified tire inflation pressure.

 Incorrect inflation pressures are a frequent cause of tire problems and flat tires. Tire pressure also has a major effect on your BMW's handling response. Check tire inflation pressures on a regular basis (refer to page 22), at least every two weeks and before every long trip. If you fail to observe these precautions, incorrect tire pressures can cause driving instability and tire damage, ultimately resulting in an accident. ◀

Tire condition



Tire tread – tire damage

Inspect your tires frequently for tread wear, signs of damage and for foreign objects lodged in the tread. Check the tread depth.

The tread depth should not drop below 0.12 in (3 mm), even though, for example the legally specified minimum tread depth in Europe is only 0.063 in (1.6 mm). Below a tread depth of 0.12 in (3 mm) there is an increased risk of hydroplaning, even at relatively moderate speeds and with only small amounts of water on the road.

Tread wear indicators, refer to arrow, are embedded around the tire circumference in the base of the tire tread. Their locations are indicated on the tire sidewall with TWI – Tread Wear Indicator. At a tread depth of 0.063 in

(1.6 mm) these indicators, signal that the tires have reached the legally permissible wear limit.

 Do not drive on a deflated (flat) tire. A flat tire greatly impairs steering and braking response, and can lead to complete loss of control over the vehicle.

Avoid overloading the vehicle so that the permitted load on the tires is not exceeded. Overloading leads to overheating and causes damage inside the tires. The ultimate result can assume the form of a sudden air loss.

Unusual vibrations encountered during normal vehicle operation can indicate a flat tire or some other vehicle malfunction. The type of problem can be caused by contact with curbs, etc. This is also true for irregularities in the vehicle's handling characteristics, such as a pronounced tendency to pull to the left or right. Should this occur, respond by immediately reducing your speed. Proceed carefully to the nearest BMW center or professional tire center, or have the vehicle towed in to have it, its wheels and tires inspected.

Tire damage (up to and including blow-outs) can endanger the lives of both the vehicle occupants and other road users. ◀

110 Tire replacement

To maintain good handling and vehicle response, use only tires of a single tread configuration from a single manufacturer. BMW tests wheel and tire combinations and approves them.

DOT Quality Grades

Treadwear

Traction AA A B C

Temperature A B C

 All passenger car tires must conform to Federal Safety Requirements in addition to these grades. ◀

Treadwear

The treadwear grade is a comparative rating based on the wear rate of the tire when tested under controlled conditions on a specified government test course.

For example, a tire graded 150 would wear one and one-half (1½) times as well on the government course as a tire graded 100. The relative performance of tires depends upon the actual conditions of their use, however, and may depart significantly from the norm due to variations in driving habits, service practices and differences in road characteristics and climate.

Traction

The traction grades, from highest to lowest, are AA, A, B and C.

Those grades represent the tire's ability to stop on wet pavement as measured under controlled conditions on specified government test surfaces of asphalt and concrete. A tire marked C may have poor traction performance.

 The traction grade assigned to this tire is based on straight-ahead braking traction tests, and does not include acceleration, cornering, hydroplaning, or peak traction characteristics. ◀

Temperature

The temperature grades are A (the highest), B and C, representing the tire's resistance to the generation of heat and its ability to dissipate heat when tested under controlled conditions on a specified indoor laboratory test wheel.

Sustained high temperature can cause the material of the tire to degenerate and reduce tire life, and excessive temperature can lead to a sudden flat tire. The grade C corresponds to a level of performance which all passenger car tires must meet under the Federal

Motor Car Safety Standard No. 109. Grades B and A represent higher levels of performance on the laboratory test wheel than the minimum required by law.

 The temperature grade for this tire is established for a tire that is properly inflated and not overloaded. Excessive speed, underinflation, or excessive loading, either separately or in combination, can cause heat buildup and possible tire failure. ◀

Uniform Tire Quality Grading

Quality grades can be found where applicable on the tire sidewall between tread shoulder and maximum section width. For example:

Treadwear 200

Traction AA

Temperature A

Tire replacement



Do not use retreaded tires, since driving safety may be impaired. This is due to the possible variations in casing structures and, in some cases, to their extreme age, which can lead to a decrease in their durability. ◀

Tire age

The date on which the tire was manufactured is indicated by the code on the sidewall: DOT ... 3401 indicates that the tire was manufactured in week 34 of the year 2001.

Although tires may have a theoretical service life of up to 10 years, BMW strongly recommends that you replace all tires after an absolute maximum of 6 years.

Wheel and tire combinations

The right choice



Never mount wheels and tires that have not been specifically approved by BMW for use on your particular model. Although other wheels and tires may theoretically have the same dimensions, variations in factors such as manufacturing tolerances can result in contact between tire and bodywork, ultimately leading to serious accidents. If non-approved wheels and tires are used, BMW cannot evaluate their suitability, and therefore cannot be held liable for driving safety. ◀

BMW has tested certain tires for each tire size, rated them according to road safety and approved them. Your BMW center can inform you which tires have been tested in this way. Observe possible national guidelines, e.g. regarding entry into vehicle documents.



Because various systems on your vehicle, such as ABS, DSC and the Flat Tire Monitor, rely on the correct combination of tires and wheels for optimal operation, their operation may be adversely affected if other tires and/or wheels are mounted. You should therefore ensure that tires from a single manufacturer with the

same tread pattern are mounted at all four wheels. After installing a spare tire in response to a flat tire you should always ensure that a tire of the original specifications is remounted as soon as possible. ◀



The use of rims and wheel bolts that do not meet the specifications of the original factory-installed equipment will affect the safe operation of your vehicle and may cause an accident and personal injury. Never mix tires of different design, such as steel-belted radials with radial bias-belted or bias-ply tires, etc. Mixing tire types will adversely affect roadholding and can lead to loss of vehicle control. ◀

Storage

Store tires in a cool, dry place, protecting them against light whenever possible. Protect the tires against contact with oil, grease and fuel.

Choosing the right tire

BMW recommends winter tires (M+S radial tires) for driving in adverse winter road conditions. While "all-season" tires (M+S designation) provide better winter traction than summer tires with the load ratings H, V, W, Y and ZR, they generally do not achieve the performance of winter tires.

In the interests of safe tracking and steering response, install radial tires made by the same manufacturer and with the same tread configuration on all four wheels if you elect to mount winter tires.



Never exceed the maximum speed approved for your specific winter tires.

Unprofessional attempts by laymen to service tires can lead to damage and accidents.

Have this work performed by skilled professionals only. Any BMW center has the required technical knowledge and the proper equipment and will be happy to assist you. ◀

Tire condition, tire inflation pressure

When the tread wears to a depth of less than 0.16 in (4 mm) there is a substantial reduction in the tire's ability to provide adequate traction under winter driving conditions. To ensure continued safety, tires with this amount of tread wear should always be replaced.

Comply with the specified tire inflation pressures – and be sure to have the wheel and tire assemblies balanced every time you change the wheels/tires.

Snow chains*

The use of BMW narrow-link snow chains on winter tires is approved only in pairs and only on the rear wheels. Comply with all manufacturer's safety precautions when mounting the chains. Do not exceed a speed of 30 mph (50 km/h) while driving with mounted snow chains.



It is not possible to mount snow chains with 18-inch wheels and tires. ◀



To unlock

Pull the lever located under the left-hand side of the instrument panel.

 Do not attempt to service your vehicle if you do not have the required technical background. Failure to work in an informed, professional manner when servicing components and materials constitutes a safety hazard for vehicle occupants and other road users. If you are not familiar with the guidelines, please have the operations performed by your BMW center. ◀



To open

Pull the release handle and open the hood.



To close

Allow the hood to fall from a height of about 4 in (10 cm) so that it audibly engages.

 To avoid injuries, be sure that the travel path of the hood is clear when it is closed, observing the same precautions recommended for all closing procedures. If you notice that the hood is not completely closed while driving, stop immediately and close it securely. ◀

114 Engine compartment essentials

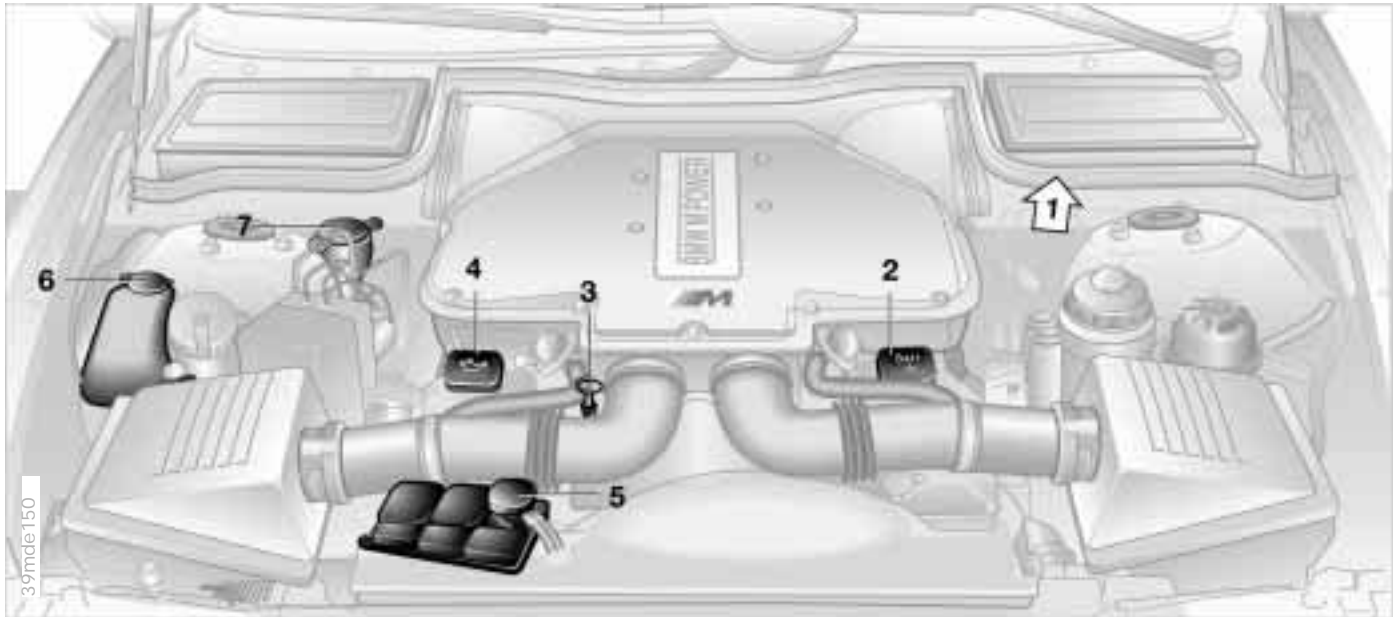

1 Reservoir for brake fluid (under the housing of the microfilter) [118](#)

2 Auxiliary terminal for jump starting [133](#)

3 Engine oil dipstick [115](#)

4 Engine oil filler neck [116](#)

5 Coolant expansion tank [118](#)

6 Reservoir for the intensive-cleaning system [115](#)

7 Reservoir for the windshield and headlamp washer system [115](#)



Headlamp and windshield washer system

Capacity in US quarts (liters).

Windshield washer:

Approx. 3.7 US quarts (3.5 liters)

With headlamp-washing system:

Approx. 6.3 US quarts (6.0 liters).

Fill with water and – if required – with a washer antifreeze (according to manufacturer's recommendations).



We recommend that you mix the washer fluid before adding it to the reservoir. ◀



Intensive-cleaning washer reservoir

Capacity approx. 1.1 US quarts (1.0 liter).

Fill with intensive-cleaning washer fluid. It resists freezing down to approx. -17°F (-27°C) and is available from your BMW center.



Antifreeze agents or intensive-action washer fluids for the washer systems are highly inflammable. For this reason, keep them away from sources of flame and store them only in their original containers. Store them so that they are inaccessible to children. Comply with the instructions on the containers. ◀

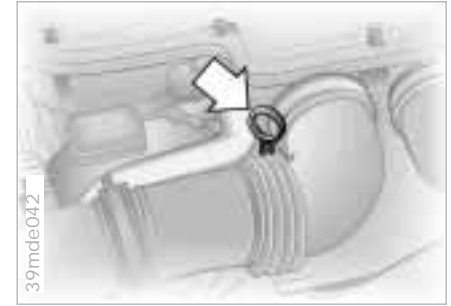

Checking oil level

1. Park the vehicle on a level surface
2. Allow the engine to run at operating temperature for at least 15 seconds at idle, then shut it off
3. After approx. one minute, pull the dipstick out and wipe it off with a clean lint-free cloth, paper towel, or similar material
4. Carefully push the dipstick all the way into the guide tube and pull it out again
5. The oil level should be between the two marks on the dipstick.

As with fuel economy, oil consumption is directly influenced by your driving style and vehicle operating conditions.

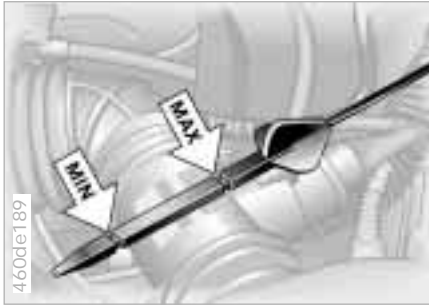

The oil volume between the two marks on the dipstick corresponds to approx. 1.1 US quarts (1 liter). Do not fill beyond the upper mark on the dipstick. Excess oil will damage the engine.

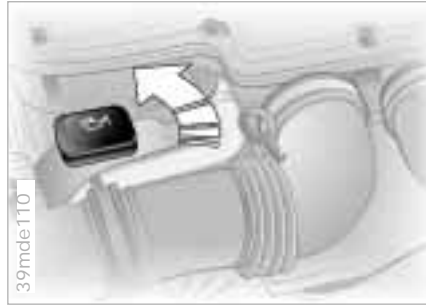

To add oil

While you should wait until the level has dropped to just above the lower marks before adding oil, you should never allow the oil level to fall below this mark.

 BMW engines are designed to operate without oil additives; the use of additives could lead to damage in some cases. This is also true for the manual transmission, the differential, and the power steering system. ◀

Recommendation: have the oil changed by your BMW center only.

 Continuous exposure to used oil has caused cancer in laboratory testing.

For this reason, any skin areas that come into contact with oil should be thoroughly washed with soap and water.

Store oil, grease, etc., out of reach of children. Comply with warning labels and information on containers. ◀

 Comply with the applicable environmental laws regulating the disposal of used oil. ◀

Specified engine oils

The quality of the engine oil is extremely important for the function and service life of an engine. Based on extensive testing, BMW approves only certain grades of engine oil.

Use only approved "BMW High Performance Synthetic Oil."

If you are unable to obtain "BMW High Performance Synthetic Oil," you can add small amounts of synthetic oil in between oil changes. Only use oils with the API SH specification or higher.

 Ask your BMW center for details concerning the specific "BMW High Performance Synthetic Oil" or "special oils" which have been approved. ◀

You can also call BMW of North America at 1-800-831-1117 or visit this website: www.bmwusa.com to obtain this information.

Viscosity ratings

Viscosity is the oil flow rating as established in SAE classes.

The selection of the correct SAE class depends on the climatic conditions in the area where you typically drive your BMW.

 Approved oils are in SAE classes 5W-40 and 5W-30. ◀

These oils may be used for driving in all ambient temperatures.



Do not add coolant to the cooling system when the engine is hot. If you attempt to do so, escaping coolant can cause scalds. To avoid the possibility of secondary damage, never use anything other than factory-approved, nitrite and amino-free extended-duty antifreeze with corrosion inhibitor. Your BMW center is familiar with these specifications. Antifreeze and anti-corrosion agents are hazardous to health. You should always store them in their original containers and in a location which is out of reach of children. For this reason, do not spill antifreeze with corrosion inhibitor on hot engine parts. It could ignite and cause burns. ◀



Checking coolant level and adding coolant

Correct coolant level when the engine is cold (approx. 68 °F/20 °C): In the translucent container's visible range, as far as the graduation marked KALT/COLD.

1. Turn the cap counterclockwise slightly in order to allow accumulated pressure to escape
2. If the coolant is low, slowly add coolant until the correct level is reached – do not overfill.

 Comply with the applicable environmental laws regulating the disposal of extended-duty antifreeze with corrosion inhibitor. ◀

Brake fluid

Brake fluid level



The warning lamp for the brake system hydraulic circuits comes on and/or the message "CHECK BRAKE FLUID" appears in the Check Control: Brake fluid level too low.



To add brake fluid

The brake fluid reservoir is located under the microfilter housing on the driver's side of the vehicle. For adding brake fluid or for determining and correcting the cause of brake fluid loss, consult your BMW center. Your BMW center is familiar with the specifications for factory-approved brake fluids (DOT 4).

Brake fluid loss may result in extended brake pedal travel. If this occurs, refer to the information on page 108.



Brake fluid is hygroscopic, that is, it absorbs moisture from the air over time.

In order to ensure the safety and reliability of the brake system, have the brake fluid changed every two years at a BMW center. Refer also to the Service and Warranty Information Booklet (US models) or the Warranty and Service Guide Booklet (Canadian models). Brake fluid is hazardous to health and damages the vehicle's paint. You should always store it in its original container and in a location which is out of reach of children. Do not spill the fluid and do not fill the brake fluid reservoir beyond the MAX mark. The brake fluid could ignite upon contact with hot engine parts and cause serious burns. ◀



Comply with the applicable environmental laws regulating the disposal of brake fluid. ◀



The BMW Maintenance System has been designed as a reliable means of providing maximum driving and operating safety – and as cost-effectively as possible for you.

Please keep in mind that regular maintenance is not only necessary for the safety of your vehicle, but also plays a significant role in maintaining its resale value.

Service Interval Display

Conventional systems rely solely on distance traveled to determine when service is due. The BMW Maintenance System, on the other hand, began many years ago to take the actual conditions under which the vehicle is driven into consideration. After all, different drivers can accumulate mileage in very different ways.

From a maintenance point of view, 62,000 miles (100,000 km) of short-distance driving cannot be compared with 62,000 miles (100,000 km) of long-distance highway travel.

In response to this fact, the BMW Maintenance System monitors operating conditions as the basis for determining the optimum service intervals for your individual vehicle. The BMW Maintenance System includes the Engine Oil Service and Inspections I and II.

Determining the maintenance intervals according to the actual loads on the vehicle covers every kind of operating situation. However, even those who drive only short distances – significantly less than 6,000 miles (10,000 km) annually – should have the engine oil changed at least every 2 years since oil deteriorates over time, regardless of use.

Service and Warranty Information Booklet (US models)/Warranty and Service Guide Booklet (Canadian models)

For additional information on maintenance intervals and procedures, please refer to the Service and Warranty Information Booklet (US models) or the Warranty and Service Guide Booklet (Canadian models).

As a precaution against corrosion, it is advisable to have the body checked for damage from rocks or gravel at the same time, depending upon operating conditions.

 Have your vehicle's maintenance and repairs performed at your BMW center.

Be sure that all maintenance work is confirmed in the Service and Warranty Information Booklet (US models) or the Warranty and Service Guide Booklet (Canadian models). These entries are your proof that the vehicle has received regular maintenance. They are also a requirement for warranty claims. ◀

Light-emitting diodes (LEDs)

Light-emitting diodes installed behind translucent lenses serve as the light source for many of the controls and displays in your vehicle. The concept behind their operation is related to that employed for lasers.

 Do not remove the protective lens and avoid staring directly at the unfiltered beam for extended periods (several hours), as inflammation of the iris could result. ◀

California laws require us to state the following warning:

 Engine exhaust, some of its constituents, and certain vehicle components contain or emit chemicals known to the State of California to cause cancer and birth defects and reproductive harm. In addition, certain fluids contained in vehicles and certain products of component wear contain or emit chemicals known to the State of California to cause cancer and birth defects or other reproductive harm. Battery posts, terminals and related accessories contain lead and lead compounds. Wash your hands after handling. Used engine oil contains chemicals that have caused cancer in laboratory animals. Always protect your skin by washing thoroughly with soap and water. ◀

OBD interface socket



The Onboard Diagnostic (OBD) interface socket is located on the left of the driver's side at the bottom of the instrument panel and under a cover. The cover has the letters "OBD" on it.

The purpose of the OBD (Onboard-Diagnostics) system is to assure proper emission-control system operation for the vehicle's lifetime by monitoring emissions-related components and systems to detect deterioration and malfunction.



An illuminated indicator informs you of the need for service, not of the need to stop the vehicle. However, the systems should be checked by your BMW center at the earliest possible opportunity.

Under certain conditions, the indicator will blink or flash. This indicates a rather severe level of engine misfire. When this occurs, you should reduce the speed and consult the nearest BMW center as soon as possible. Severe engine misfire over only a short period of time can seriously damage emissions-control components, especially the catalytic converter.



Service Engine Soon warning lamp for Canadian models.



When the fuel filler cap is not properly tightened, the OBD system can detect the vapor leak and the indicator will light up. If the filler cap is subsequently tightened, the indicator should go out within a few days. ◀





Overview

Controls and features

Operation, maintenance

Owner service procedures

Technical data

Index

Overview

Controls

Maintenance

Repairs

Data

Index



The onboard tool kit is located in the luggage compartment lid.

Loosen the wingnut to open.

Windshield wiper blades

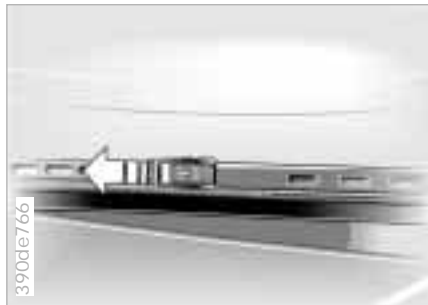

1. Lift the wiper arm up slightly and hold it firmly
2. Press back the release (arrow) and pull the wiper blade back toward the base of the wiper arm
3. Install the new blade and slide the release back into position.

 Use only wiper blades approved by BMW. ◀

Lamps and bulbs

The lamps and bulbs are essential factors contributing to the safety of your vehicle. Therefore, comply fully with the following instructions during bulb replacement. If you are not familiar with any of the procedures, consult your BMW center.

 Do not touch the glass portion of a new bulb with your bare hands since even small amounts of impurities burn in to the surface and reduce the service life of the bulb. Use a clean cloth, paper napkin, or a similar material, or hold the bulb by its metallic base. ◀

A replacement bulb set is available from your BMW center.

 Always switch off all electrical accessories and systems before working on them. As an alternative, you can also disconnect the cable from the battery's negative terminal. Failure to observe this precaution can lead to short circuits.

To prevent injuries and damage, comply with any instructions provided by the bulb manufacturer. ◀

Lamps and bulbs

Xenon lamps

The service life of these bulbs is very long and the probability of a failure is very low, provided that they are not switched on and off an unusual number of times. If one of these bulbs should nevertheless fail, it is possible to continue driving with great caution using the fog lamps, provided traffic laws in your area do not prohibit this.

 Never attempt to perform bulb changes or any other service operations on the xenon lamps. Always have them serviced by professional technicians. The extremely high voltages at which these lamps operate constitute a potentially lethal safety hazard. ◀

 When cleaning the headlamps, please observe the following:

- ▷ Do not clean by wiping with a dry cloth (this causes scratches). Never use abrasives or strong solvents to clean the covers
- ▷ Remove dirt and contamination (such as insects) by soaking with BMW Car Shampoo and then rinsing with ample water
- ▷ Always use a deicer spray to remove accumulated ice and snow – never use a scraper. ◀



Standing lamps

10 watt bulb

 The bulb holder and reflector are a single unit and are both changed at the same time. ◀

1. Turn the bulb holder with reflector to the left (arrow) and remove
2. Disconnect the plug
3. Plug the new bulb holder into the plug connector. Be sure that it is securely engaged
4. Insert the reflector with bulb holder and turn to the right as far as possible.



Turn signal indicators/parking lamps (side marker lamps), front

Dual-filament bulb, 21 watt

1. Turn the bulb holder to the left and remove
2. Remove and replace the bulb.



Side turn signal indicators

5 watt bulb

1. Use finger pressure against the rear end of the lens (arrow) to press it forward for removal
2. Apply gentle pressure to the bulb while turning it to the left to remove.



Front fog lamps

HB4, 51 watt bulb

 The bulb is pressurized. Therefore, wear safety glasses and protective gloves. Failure to observe these precautions can result in physical injury if the bulb breaks. ◀

1. Pull the cover panel next to the headlamp forward to remove
2. Loosen the screw, refer to arrow, and swing the lamp assembly out
3. Release the spring on the back of the lamp and turn the cover to the left
4. Release the clamp, remove the contact base and replace the bulb.

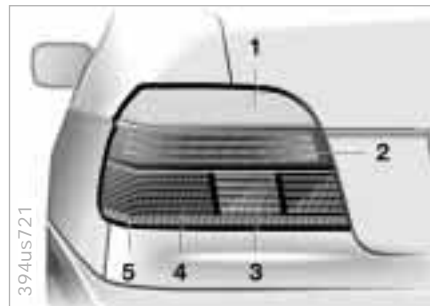

Tail lamps

Rear lamp/side marker lamps:

Light-emitting diodes

Remaining bulbs: 21 watt

- | | | |
|---|-----------------------------|-------|
| 1 | Turn signal indicator | white |
| 2 | Rear lamp/side marker lamps | red |
| 3 | Backup lamps | white |
| 4 | Brake lamps | red |
| 5 | Reflector | red |



Please contact your BMW center if there is a defect in the rear lamp/side marker lamp assembly. ◀



1. Use the upper handle to fold down the side panel in the luggage compartment
2. Turn the corresponding bulb holder to the left (arrow) and remove it
3. Press the defective bulb gently and turn it to the left. Remove the bulb and replace it
4. Insert the bulb holder and turn to the right as far as possible.

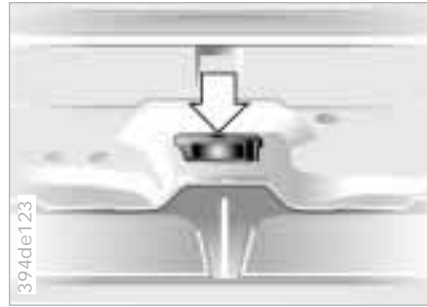

Center (high-mount) brake lamp

21 watt bulb

1. Open the luggage compartment lid
2. Use a screwdriver to unclip the cover panel (on the underside of the storage tray) (arrow)
3. Turn the bulb holder to the left and remove
4. Apply gentle pressure to the bulb while turning it to the left to remove.



License plate lamps

5 watt bulb

1. Insert a screwdriver into the slot and press to the left (arrow); this dislodges the lamp
2. Remove the lamp and replace the bulb.



Precautions in case of a flat tire: Stop the vehicle as far as possible from passing traffic. Switch on the hazard warning flashers.

Turn the steering wheel to the straight-ahead position, remove the key and engage the steering lock. Shift into 1st or reverse and engage the parking brake.

All passengers should be outside the vehicle and well away from your immediate working area (behind a guardrail, for instance).

If necessary, set up your warning triangle or portable hazard warning lamp on the roadside at an appropriate distance from the rear of the vehicle. Comply with all safety guidelines and regulations. ◀

M Mobility system

For repairing a flat tire, you will find an M Mobility system in the BMW M5. With the aid of this system, you can apply a liquid sealant to the inside of the tire, thereby sealing off the damaged area, and then continue driving.

The M Mobility system makes the transport of a spare wheel superfluous and minimizes the curb weight.



The M Mobility system is located in the luggage compartment under the floor mat:

1. Lift up the floor mat and then raise the front cover panel
2. Loosen the M Mobility system from its storage location.



Please note that the system's sealant container must be replaced every three years by your BMW center if the device is not used. ◀





This is part of the M Mobility system

- 1 On/Off switch
- 2 Connection hose with pressure gauge for connecting the compressor with the sealant container or to connect the compressor to the wheel
- 3 Pressure gauge for indicating the tire pressure
- 4 Connector hose from the sealant container to the wheel
- 5 Warning sticker for maximum speed
- 6 Plug and cable for the cigarette lighter socket
- 7 Protective gloves (not illustrated)

Repairing a flat tire

Use the M Mobility system

 If possible, leave the foreign object in the tire. ◀

 Do not exceed the maximum speeds indicated below, as an accident could result.

Before you use the M Mobility system, read the warnings and danger notices on the device carefully. ◀

1. Remove the warning sticker 5 for maximum speed that is located on top of the device and affix it to the steering wheel



2. Take off the round cover and extract hose 4. Unscrew the valve stem cap from the defective tire, then screw the hose onto the valve stem. Avoid losing the valve stem cap



3. Flip open the cover and pull out the enclosed protective gloves. Take out hose 2 with the pressure gauge and screw it to the connection on the sealant container, as shown in the illustration

4. Make sure that the system has been switched off (position 0). Take out plug 6 and plug it into the cigarette lighter socket in the passenger compartment (refer to page 98)

130 Repairing a flat tire

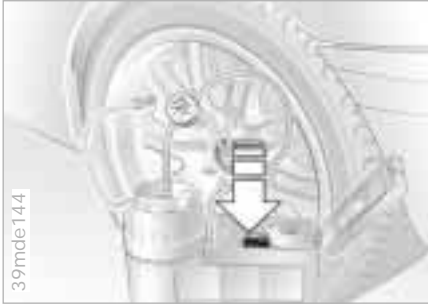

5. Make sure that the screw on the rear of the pressure gauge 3 is tightened down. Turn on the M Mobility system (position I, refer to illustration) and allow 3 minutes to elapse, to let the sealant flow in. At this point, it is insignificant what the tire pressure is
6. Turn the device off.
Disconnect the connector hose from the sealant container and the wheel valve. Stow the M Mobility system in the luggage compartment

7. Right afterward, drive at least 1.2 miles (2 km), so that the liquid sealant distributes evenly throughout the inside of the tire. If possible drive at no less than 15 mph (20 km/h), but not more than 40 mph (60 km/h). Stop in a suitable spot



8. Take out the hose with the pressure gauge and screw it onto the valve. Take out the plug and plug it into the cigarette lighter socket in the passenger compartment
9. Reset the tire pressure to 29 psi (200 kilopascal), and:
 - ▷ Increase the tire pressure: turn on the M Mobility system (position I). To check the new tire pressure briefly turn off the device
 - ▷ Reducing tire pressure: turn the screw on the back of the pressure gauge, a valve located there will open

Repairing a flat tire

 If the inflation pressure does not hold, complete step 10 and then repeat steps 7 through 10. The use of the M Mobility system may be ineffective if the damaged area in the tire is larger than approx. 0.15 in (4 mm). If it should prove impossible to restore the tire to operational status using the M Mobility system, please contact the nearest BMW center or BMW Roadside Assistance at 1-800-332-4269. ◀

10. Unscrew the hose from the valve and stow the M Mobility system in the luggage compartment. Screw the cap back onto the valve stem.

When you start driving again, do not exceed the permissible maximum speed of 50 mph (80 km/h).

You will find corresponding instructions for using the M Mobility system on the device.

Replace the defective tire as soon as possible and have the wheel and tire balanced. Reactivate the Flat Tire Monitor, for additional information refer to page 82. Have the M Mobility system recharged. Contact your BMW center for this.

Protect valve stems and valves from dirt using screw-on valve stem caps. Dirty valve stems frequently lead to slow pressure loss.

Battery

 Battery posts, terminals and related accessories contain lead and lead compounds. Wash hands after handling. ◀

Battery care

The battery is completely maintenance-free. That means that the original electrolyte will normally last for the service life of the battery under moderate climatic conditions.

 Please consult the staff at your BMW center whenever you have any questions concerning the battery. The battery is completely maintenance-free; the following section is provided for your information only. ◀

 Never disconnect the battery when the engine is running; the ensuing voltage surge would seriously damage the vehicle's onboard electronic systems. ◀

Charging the battery

Recharge the battery only with the engine off, using the auxiliary terminals provided in the engine compartment (for information on these terminals refer to "Jump-starting" on page 133).



Avoid environmental pollution when disposing of old batteries. ◀



Return used batteries to a recycling point or your BMW center. Maintain the battery in an upright position for transport and storage. Secure the battery to prevent it from tilting during transport. ◀

Fuses**In the glove compartment**

Open the glove compartment and turn the two white quick-release fasteners to the left.

**In the luggage compartment**

Use the handle to pull down the trim on the right wall.



Do not attempt to repair a blown fuse or replace it with a fuse having a different color or amperage rating. Installing the wrong fuse could cause a fire in the vehicle resulting from a circuit overload. ◀

Jump-starting

Do not use spray starter fluids to start the engine.

When your battery is discharged you can use two jumper cables to start your vehicle with power from the battery in a second vehicle. You can also use the same method to help start another vehicle. Use only jumper cables with fully insulated handles on the terminal clamps.



Do not touch high-voltage wiring and cables on a running engine. There is a risk of fatal injury if you do this. Carefully observe the following instructions to avoid personal injury and/or damage to one or both vehicles. ◀

1. Ensure that the battery in the support vehicle is also rated at 12 volts. This information is provided on the top of the battery casing
2. Do not disconnect your battery from your vehicle's electrical system. Switch off all electrical accessories in both vehicles
3. Make absolutely certain that there is no contact between the bodywork of the two vehicles – short circuit hazard
4. Start the engine on the support vehicle and allow it to run

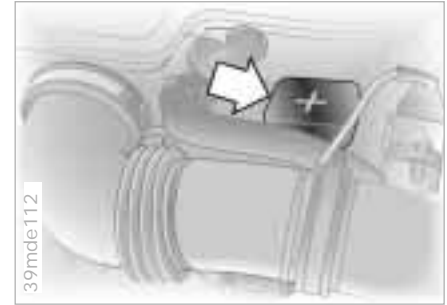

5. Use one jumper cable (+) to connect the positive terminal of the battery in the support vehicle with the auxiliary positive terminal provided in the engine compartment of your BMW specifically for jump-starting. The cover of the auxiliary terminal for use in jump-starting your BMW is identified by a "+" symbol, refer to illustration. Flip the cap out to open

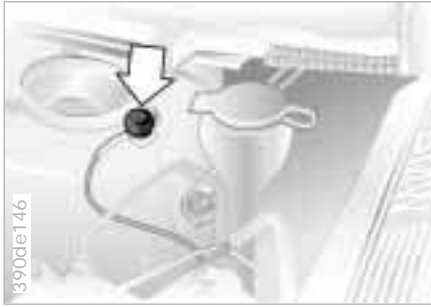

6. Next, connect one end of the other jumper cable (-) to either the support vehicle's negative battery terminal or a suitable ground on its engine or bodywork. Connect the other end to the negative battery terminal or a suitable ground on the vehicle being started. There is a special nut on the strut dome of your BMW (refer to the arrow in the illustration)



Always adhere to this sequence when connecting jumper cables; failure to observe this procedure can lead to sparks at the battery terminals and pose an injury hazard. ◀

7. Start the support vehicle's engine and let it run at an increased idling speed for a few minutes. Start the engine on the vehicle needing the jump-start, and allow it to run as usual. If the first start attempt is not successful, wait a few minutes before another attempt in order to allow the discharged battery to recharge
8. Before disconnecting the jumper cables let the engines run for a few minutes
9. Then disconnect the jumper cables in reverse sequence.

Depending on the cause of the fault, have the battery recharged by your BMW center.

Towing the vehicle



Tow fitting

The screw-in tow fitting is stored in the onboard tool kit; be sure that it remains in the vehicle at all times. This fitting is designed for installation in the tow sockets located at the front and rear of the vehicle, and is intended for towing on proper road surfaces only. It should not be used to pull a vehicle out of deep snow, mud, sand, etc. Always observe all applicable towing laws and regulations.

Access to tow sockets

Front:

Apply pressure to the arrow symbol on the cover; remove the cover.

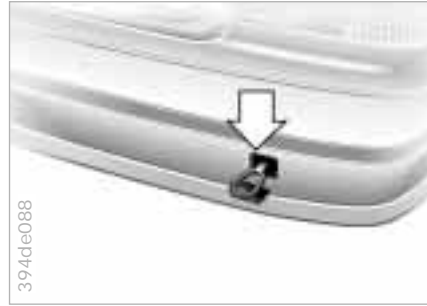

Rear:

Apply pressure to the arrow symbol on the cover; remove the cover.

 Screw the tow fitting in until it bottoms firmly. Failure to screw the fitting in securely can lead to thread damage.

Never attach tie-down hooks, chains, straps, or tow hooks to tie rods, control arms, or any other part of the vehicle suspension, as severe damage to these components will occur, leading to possible accidents. ◀

Use only a nylon towing strap to tow the vehicle. The inherent resilience of this material helps protect both vehicles from sudden jerking movements.

 Keep the vehicles in line and avoid towing at an offset angle. Ensure that the tow rope connecting the two vehicles is tight, with no slack, before starting off. ◀

 The towed vehicle should always be the lighter of the two vehicles. If this is not the case, it is no longer possible to control vehicle response. ◀

Tow-starting

It is better to start the vehicle's engine by jump-starting. For instructions on jump-starting, refer to page 133.

Never attempt to use your vehicle to push another vehicle, as damage to the energy-absorbing bumpers could result.

Towing a vehicle

1. Shift lever in neutral
2. Towing speed:
Max. 45 mph (70 km/h)
3. Towing distance:
Max. 95 miles (150 km/h)
4. Leave the ignition key in position 1 to ensure that the brake lamps, turn signals, horn and windshield wipers remain operative, and to prevent the steering lock detent from engaging
5. Switch on the hazard-warning system (comply with official regulations).

Find some means of identifying the vehicle in tow, for instance, place a sign or warning triangle in the rear window.

 Make sure that the ignition key remains in position 1 even if the electrical system has failed to prevent the steering lock from engaging. The steering and brakes are without power assist when the engine is not running. This means that increased effort is required for steering and braking. ◀

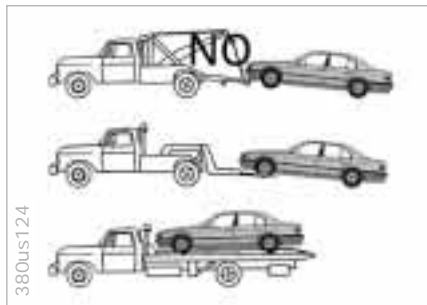

Towing with a commercial tow truck

- ▷ Do not tow with sling-type equipment
- ▷ Use a wheel-lift or flatbed equipment
- ▷ Please comply with applicable towing laws.

 Never allow passengers to ride in a towed vehicle for any reason. ◀

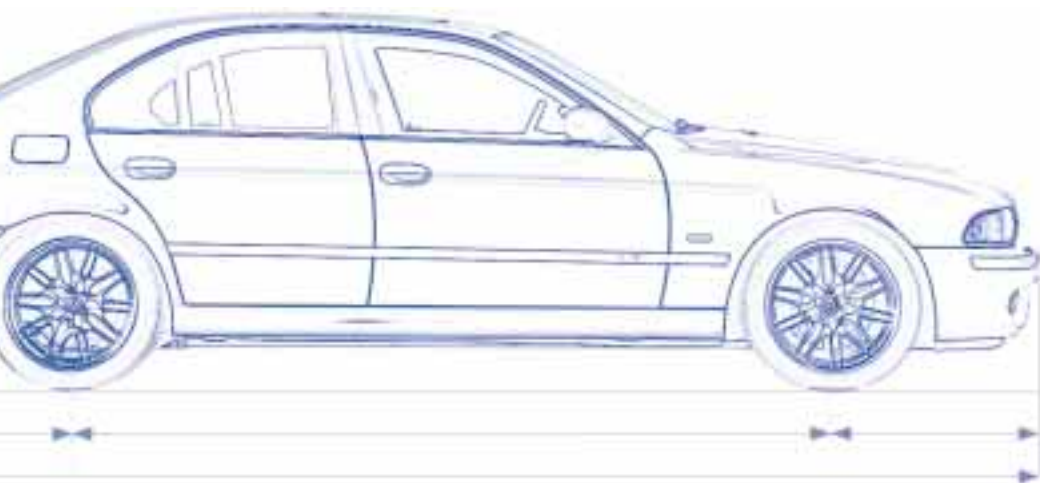

Overview

Controls and features

Operation, maintenance

Owner service procedures

Technical data

Index



Overview

Controls

Maintenance

Repairs

Data

Index

140 **Engine data**

		BMW M5
Displacement	cu in (cm ³)	301.5 (4,941)
Number of cylinders		8
Maximum output at engine speed	hp rpm	394 6,600
Maximum torque at engine speed	lb ft (Nm) rpm	368 (500) 3,800
Compression ratio	ε	11.0
Stroke	in (mm)	3.50 (89.0)
Bore	in (mm)	3.70 (94.0)
Fuel-injection system		Digital electronic engine-management system

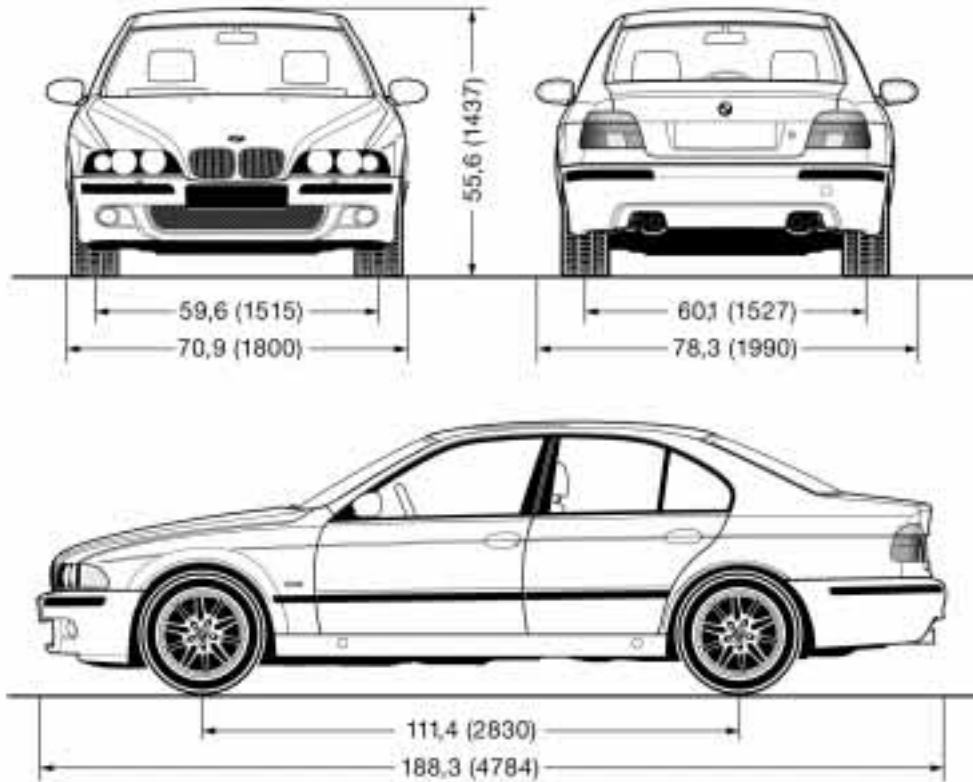

All dimensions are given in inches (mm). Minimum turning circle dia.: 38.1 ft (11.6 m)

142 Weights

BMW M5

Curb weight (with one person, ready for operation, full tank of fuel, options not included)

lbs. (kg) 4,024 (1,825)

Approved gross vehicle weight

lbs. (kg) 5,049 (2,290)

Approved front axle load

lbs. (kg) 2,426 (1,100)

Approved rear axle load

lbs. (kg) 2,701 (1,225)

Approved roof load capacity

lbs. (kg) 220 (100)

Approved axle loads and approved gross vehicle weight may not be exceeded.

Luggage compartment capacity

cu ft (liters) 16.2 (460)

			Notes
Fuel tank of which reserve	gal. (liters) gal. (liters)	approx. 18.5 (approx. 70) approx. 2.5 (approx. 10)	Fuel specification: page 22
Windshield washer system with headlamp washer system Intensive cleaning system	quarts (liters) quarts (liters) quarts (liters)	approx. 3.7 (approx. 3.5) approx. 6.3 (approx. 6.0) approx. 1.1 (approx. 1.0)	For details: page 115
Cooling system including heater circuit	quarts (liters)	12.7 (12.0)	For details: page 117
Engine oil filter change	quarts (liters)	6.9 (6.5)	"BMW High Performance Synthetic Oil," for details: page 117
Manual transmission and differential		-	Oil change at the 1,200-mile-service, then the oil never needs to be changed again

A B C

P Q R



Overview

Controls and features

Operation, maintenance

Owner service procedures

Technical data

Index

Overview

Controls

Maintenance

Repairs

Data

Index

Everything from A to Z

A

ABS (Antilock Brake System) 17, 107
Activated-charcoal filter 91
Active seat 43
Adding
 brake fluid 118✍️
 engine coolant 118✍️
 engine oil 116✍️
 washer fluid 115✍️
Adjusting
 backrest 41
 head restraints 43
 mirrors 48
 seats 40
 steering wheel 47
 temperature 89
Air conditioning 90
Air distribution 89
Air pressure, tires 22, 109
Air supply 89
Airbags 17, 49
Alarm system 35
Anchorage points
 child-restraint system with
 tether strap 52
Antifreeze 118
Antilock Brake System
 (ABS) 17, 107
Aquaplaning 107, 109

Ashtray
 front 97
 rear 98
Attach vacuum cleaner 98
AUC (Automatic recirculated-air control) 90
Automatic climate
 control 87
 removing condensation
 from the windows 89
Automatic cruise control 61
Automatic curb monitor 46
Automatic dimming
 exterior mirror 48
 interior rearview mirror 48
Automatic recirculated-air
 control (AUC) 90
Automatic steering wheel
 adjustment 47
Automatic windshield
 washer 60
Average fuel
 consumption 75
Average speed 76
Avoiding unintentional
 alarms 36
Axle loads 142







B

Backrest, adjusting 41
Backup lamps 59
 bulb replacement 126✍️
Battery 131
 care 131
 charging 131
 discharged 133✍️
Belts 44
Beverage holder 97
Blower 89
BMW active seat 43
BMW comfort seat 42
BMW High Performance
 Synthetic Oil 117
BMW M sport seat 41
BMW Maintenance
 System 119
BMW Universal
 Transmitter 93
Bottle holder, refer to
 Beverage holder 97
Brake fluid 118
 disposal 118
Brake hydraulic system,
 brake pads 16
Brake system 108
 brake fluid level 108
 brake linings 108
 malfunctions 108✍️
Break-in procedures 106

Bulbs and lamps 124

C

California Proposition
 65 Warning 120
Capacities 143
Car telephone 97
Cargo loading 102
Cellular phone 97
 refer also to the separate
 Owner's Manual 97
Center (high mount) brake
 lamp 127
Central locking system 26
 key 31
Charging the battery 132✍️
CHECK button 66
Check Control 66
Check engine oil
 level 115✍️
Check tire inflation
 pressure 22✍️, 109
Child seats 51
Child-restraint
 installation 53
Child-restraint system with
 tether strap 52
Cigarette lighter 98
Clock 70
 refer also to the "Owner's
 Manual for Onboard
 Computer"

- Cockpit [14](#)
- Code [76](#)
 - activating [76](#)
 - deactivating [76](#)
 - refer also to the "Owner's Manual for Onboard Computer" selecting [76](#)
- Comfort seat [42](#)
- Compartments [96](#)
- Computer [73](#)
 - refer also to the "Owner's Manual for Onboard Computer" remote control [77](#)
- Configuring individual settings [55](#)
- Consumption [75](#)
- Convenience operation of windows and sliding/tilt sunroof [27](#)
- Coolant [117](#)
 - disposal [118](#)
- Coolant temperature gauge [65](#)
- Cooling, maximum [90](#)
- Copyright [4](#)
- Cover, roller sun blinds [92](#)
- Cruise control [61](#)
- Cruising range [75](#)
- Cup holder, refer to Beverage holder [97](#)
- Curb weight [142](#)
- D**
- Date
 - calling up [70](#)
 - changing [70](#)
 - refer also to the "Owner's Manual for Onboard Computer"
- Daytime driving lamps [84](#)
- DBC (Dynamic Brake Control) [17, 80](#)
- Deactivating
 - interior motion sensor [36](#)
 - tilt alarm sensor [36](#)
- Deep water [107](#)
- Defrosting position [89](#)
- Defrosting the windows [89](#) 
- Digital clock [70](#)
 - refer also to the "Owner's Manual for Onboard Computer"
- Dimensions [141](#)
- Disconnecting the battery [133](#) 
- Displacement [140](#)
- Display lighting [85](#)
- Displays, instrument cluster [15](#)
- Disposal
 - brake fluid [118](#)
 - coolant [118](#)
 - engine oil [116](#)
- Distance from destination [74](#)
- Divided rear backrest [99](#)
- Door key [26](#)
- Doors
 - manual operation [27](#)
 - remote control [28](#)
 - unlocking and locking [27](#)
- DOT Quality Grades [110](#)
- Driving notes [107](#)
- DSC (Dynamic Stability Control) [17, 80](#)
- Dynamic Brake Control (DBC) [17, 80](#)
- Dynamic Driving Control [81](#)
- Dynamic Stability Control (DSC) [17, 80](#)
- E**
- Electric power windows [36](#)
- Electrical heating, exterior mirror [48](#)
- Electrical malfunction doors [27](#) 
- fuel filler door [20](#) 
- luggage compartment lid [32](#) 
- sliding/tilt sunroof [39](#) 
- Elements of operation [14](#)
- Emergency release of luggage compartment lid from luggage compartment's interior [34](#)
- Engine compartment [114](#)
- Engine coolant [118](#)
 - temperature gauge [65](#)
- Engine data [140](#)
- Engine oil
 - checking level [115](#)
 - consumption [115](#)
 - dipstick [115](#)
 - disposal [116](#)
 - grades [117](#)
 - level [16](#)
 - pressure [16](#)
 - temperature gauge [64](#)
- Engine performance [140](#)
- Estimated time of arrival [75](#)
- Exterior mirrors [48](#)
 - automatic dimming [48](#)
 - electrical heating [48](#)

Everything from A to Z

F

Failure messages [66](#)
Filling capacities [143](#)
First-aid kit [20](#)
Fittings, tow starting and towing [135](#)
Flashlight [96](#)
Flat tire [109](#)
Flat Tire Monitor [82](#)
Flat tire, repairing [128](#)
Fog lamps [85](#)
 bulb replacement [126](#)
Folding rear backrest [99](#)
Follow me home lamps [84](#)
Frost protection, radiator [118](#)
Fuel consumption [75](#)
 average [75](#)
Fuel filler door [20](#)
 manual operation [20](#)
Fuel gauge [64](#)
Fuel quality [22](#)
Fuel specifications [22](#)
Fuel tank capacity [143](#)
Fuse replacement [132](#)

G

Gasoline gauge [64](#)
Gasoline quality [22](#)
Glove compartment [96](#)
Gross vehicle weight [142](#)

H

Handbrake [17, 58](#)
Hands-free system [97](#)
Hazard warning triangle [20](#)
Head protection airbags [49](#)
Head restraints [43](#)
 adjusting [43](#)
Headlamp cover, care [125](#)
Headlamp flasher [59](#)
Headlamp washer system [115](#)
Headlamp washers [61](#)
Headrests [43](#)
Heated seats [46](#)
Heating with vehicle stopped [90](#)
Heavy cargo [102](#)
Height [141](#)
Height adjustment seats [41](#)
 steering wheel [47](#)
High beams [18, 59, 85](#)
High Performance Synthetic Oil [117](#)
High-mount brake lamp [127](#)
Holder for canned beverages [97](#)
Hood [113](#)
 release [113](#)
Horn [14](#)

Hydraulic Braking Assistant, refer to DBC [17, 80](#)
Hydroplaning [107, 109](#)

I

Ice warning [63](#)
Identification, tires [111](#)
Ignition key [26](#)
Ignition lock [56](#)
Imprint [4](#)
Independent ventilation system, refer to Parked-car ventilation system [92](#)
Indicator lamps [16](#)
Inflation pressure [22](#), [109](#)
INSPECTION [65](#)
Instrument cluster [15](#)
Instrument lighting [85](#)
Intensive cleaning system [115](#)
Interface socket for Onboard Diagnostics (OBD) [121](#)
Interior lamps [86](#)
Interior mirrors [48](#)
Interior motion sensor [36](#)
 deactivating [29](#)

J

Jump-starting [133](#)

K

Key Memory [55](#)
Key with remote control [26](#)
Keys [26](#)

L

Lamps and bulbs [124](#)
Lashing eyes for attaching cargo straps [34, 102](#)
Length [141](#)
License plate lamps, bulb replacement [127](#)
Lighter [98](#)
LIGHTS ON warning [84](#)
Locking and unlocking the doors [27](#)
Low beams [14, 84](#)
Low-fuel warning lamp [64](#)
Luggage compartment [34](#)
 capacity [142](#)
 manual operation [32](#)
 opening from the inside [33](#)
 opening separately [32](#)
 securing separately [32](#)

Everything from A to Z

Luggage compartment
lid 32
emergency release from
luggage compartment's
interior 34
opening from the
inside 33
opening from the
outside 33
remote control 29
securing separately 32
unlocking in case of
electrical
malfunction 32🔧
Luggage net 34
Luggage straps 34
Lumbar support 41

M

M Dynamic Driving
Control 81
M Mobility system 128
M+S tires 112
Maintenance 65, 119🔧
Malfunction displays 66
Manual operation
doors 27🔧
fuel filler door 20🔧
luggage compartment
lid 32🔧
sliding/tilt sunroof 39🔧

Manual transmission 58
Maximum cooling 90
Memory, adjustment of seat,
mirror, steering wheel 45
Microfilter 91
MID (Multi-Information
Display) 69
Mirrors 48
adjusting 48
heating 48
position adjustment
memory 45
self-defrosting 48
Modifications,
technical 120
Multifunction buttons,
steering wheel 19
Multifunction switch 59
Multi-Information Display
(MID) 69

O

OBD interface socket 121
Odometer 63
Oil
additives 116
checking level 115
consumption 115
grades 117

Oil change interval, refer to
the Service and Warranty
Information Booklet (US
models) or the Warranty
and Service Guide Booklet
(Canadian models)
Oil pressure, indicator
lamp 16
Oil specification 117
OILSERVICE 65
Onboard tool kit 124🔧
Opening and closing
from inside 31
from outside 27
with the key 27
Outside temperature
display 63

P

Park Distance Control
(PDC) 78
Parked-car ventilation
system 92
activating 72
refer also to the "Owner's
Manual for Onboard
Computer"
Parking brake 17, 58
Parking lamps 14, 84

Passenger-side mirror tilt
function 46
PDC Park Distance
Control 78
Performance Recognition for
M Dynamic Driving
Control 81
Pocket flashlight 96
Pollen filter 91
Power seat 41
Power windows 36
safety switch 37
Pressure monitor, tires 82
Pressure, tires 22🔧, 109







Q

Quality grades, tires 110

R



Rain sensor 60
Reading lamps 86
Rear backrest, folding 99
Rear window defroster 90
Rearseat backrest,
folding 99
Rearview mirrors 48
Recirculated-air mode 90
Refueling 20



Everything from A to Z

Releasing the fuel filler door
after an electrical
malfunction 20 
Reminder signal (Memo) 71
Remote control 28, 77
Remote control key 26
Removing condensation
from windows 89 
Repairing flat tire 128
Replacement key 26 
Replacement of lamps and
bulbs 124 
Replacement of windshield
wiper blades 124 
Reporting safety defects 10
Reservoir, washer
system 115 
Residual heating mode 90
Roller sun blinds 92
Roof load capacity 142
Roof-mounted luggage
rack 103

S

Safety belts 44
Safety buttons 31
Safety defects, reporting 10
Safety switch for power
windows 37
Seat heating 46

Seats 40
adjusting 40
heating 46
position adjustment
memory 45
Securing cargo 34, 102
Service and Warranty 10
Service and Warranty Infor-
mation Booklet (US
models) 119
Service Interval
Display 65, 119
Setting alarm in an
emergency 77
Side airbags 49
Side Impact Head Protection
System 49
Side-marker lamps 84
Sitting safely 40
with airbags 40
with safety belt 40
Ski bag 100
Sliding/tilt sunroof 38
closing after an electrical
malfunction 39 
convenience operation 27
power loss or
malfunction 39 
Snow chains 112

Socket for attaching power
supplies 98
Spare key 26
Speakers 97
Special characteristics of
winter tires 112
Special oils 117
Specified engine oils 117
Speed 76
average 76
Speed limit 73
Speedometer 15
Sport seat 41
Standing lamps 14, 85
Starting the engine 56
assistance 133 
problems 57, 133 
Starting, vehicle 56
Steering wheel 47
automatic adjustment 47
lock 56
position adjustment
memory 45
Steering wheel with multi-
function buttons 19
Stopwatch 71
refer also to the "Owner's
Manual for Onboard
Computer"
Storage compartments 96

Summer tires 111
Switching off the engine 57
Symbols 8

T

Tachometer 64
Tail lamps 126
bulb replacement 126 
Tank capacity 143
Technical
modifications 120
Telephone preparation 97
Temperature display
engine coolant 65
engine oil 64
outside temperature 63
Temperature gauge
coolant 65
engine oil 64
Temperature layering 91
Tether strap 52
child-restraint system 52
High support
adjustment 41
Third brake light 127
Through-loading system 99
Tilt alarm sensor 36
deactivate 29
Tilt function, passenger-side
mirror 46

Everything from A to Z



Time

- calling up 70
- changing 70
- refer also to the "Owner's Manual for Onboard Computer"

Time of arrival, estimated 75

Timer 70

Tire

- condition 109
- damage 109 
- inflation
- pressure 22 , 109
- labeling 111
- pressure monitor 82
- replacement 110
- tread 109

Tire Quality Grading 110

Tools 124

Torque 140

Tow fittings 135

Towing the vehicle 135

Track 141

Traction Control System, refer to DSC 80

Transmitter key 26

Transporting children safely 51

Tread depth, tires 109

Tread wear indicator 109

Trip odometer 63

Trunk, refer to Luggage compartment 32

Turn signal indicator 18, 59

bulb replacement 125 

Turning circle 141

U

Uniform Tire Quality Grading (UTQR) 110

Universal Transmitter 93

Use antifreeze, radiator 118

Used batteries 132

V

Vehicle battery 131

Vehicle key 26

Vehicle Memory 55

Ventilation 91

Ventilation in the rear 91

Ventilation while parked activating 72

refer also to the "Owner's Manual for Onboard Computer"

Ventilation while parked, refer to Parked-car ventilation system 92

Ventilation, draft-free 91

W

Warm feet – cool head 91

Warning lamps 16

Warning messages 66

Warning triangle 20

Warranty and Service Guide Booklet (Canadian models) 119

Washer fluids 115

Washer reservoir, filling 115

Washer system 60

Water on the roads 107

Wear indicator in the tires 109

Weights 142

Wheel and tire combinations 111

Wheelbase 141

Width 141

Windows 36

convenience operation 27

defrosting 89

Windshield washer 60

reservoir, filling 115 

Windshield wiper 60

Winter tires 112

Wiper system 60

Working in the engine compartment 113

X

Xenon lamp 125

Fuel stops

BMW recommends 

To ensure that you always have convenient access to all essential information when you stop for fuel, we recommend that you take the time to fill out the adjoining chart by entering the data that apply to your vehicle. Consult the index for individual specifications.

Fuel

Designation	
-------------	--

Please enter your preferred fuel here.

Engine oil

Quality	
---------	--

The space between the two marks on the dipstick corresponds to approx. 1.1 US quarts (1 liter).

Tire inflation pressures

	Summer tires		Winter tires	
	front	rear	front	rear
Up to 4 persons				
5 persons or 4 plus luggage				

More about BMW

bmwusa.com



The Ultimate
Driving Machine

M5 US-En